

Contract for the sale and purchase of land 2026 edition

TERM	MEANING OF TERM	NSW DAN:
vendor's agent	My Property Real Estate 111G Midson Road, Epping, NSW Australia	phone: 9868 4888 email: peter@mypropertyepping.com.au ref: Peter Horozakis
co-agent		
vendor	SUSAN STRICKLAND CAPP	
vendor's solicitor	Hills Conveyancing 24 Old Northern Rd Baulkham Hills NSW 2153	phone: (02) 9688 7777 email: enquiries@hillsconveyancing.com.au ref: Joanne Serra (JPS: Capp)
date for completion	42 days after the contract date	(clause 15)
land (address, plan details and title reference)	Unit 2 30 THIRD AVE EPPING NSW 2121 LOT 2 STRATA PLAN SP65573 Folio Identifier 2/SP65573	
improvements	<input checked="" type="checkbox"/> VACANT POSSESSION <input type="checkbox"/> subject to existing tenancies <input type="checkbox"/> HOUSE <input checked="" type="checkbox"/> garage <input type="checkbox"/> carport <input checked="" type="checkbox"/> home unit <input type="checkbox"/> carspace <input checked="" type="checkbox"/> storage space <input type="checkbox"/> none <input type="checkbox"/> other:	
attached copies	<input checked="" type="checkbox"/> documents in the List of Documents as marked or as numbered: <input type="checkbox"/> other documents:	

A real estate agent is permitted by legislation to fill up the items in this box in a sale of residential property.

inclusions	<input checked="" type="checkbox"/> air conditioning <input type="checkbox"/> curtains <input checked="" type="checkbox"/> blinds <input type="checkbox"/> dishwasher <input checked="" type="checkbox"/> built-in wardrobes <input type="checkbox"/> EV charger <input checked="" type="checkbox"/> ceiling fans <input checked="" type="checkbox"/> fixed floor coverings <input checked="" type="checkbox"/> clothes line <input checked="" type="checkbox"/> other: TV Antenna	<input checked="" type="checkbox"/> insect screens <input type="checkbox"/> internet/TV receiver <input checked="" type="checkbox"/> light fittings <input type="checkbox"/> pool equipment <input type="checkbox"/> range hood <input type="checkbox"/> solar panels <input type="checkbox"/> solar power battery <input checked="" type="checkbox"/> stove
exclusions		
purchaser		
purchaser's solicitor		
price		
deposit		
balance	(10% of the price, unless otherwise stated)	
contract date	(if not stated, the date this contract was made)	

Where there is more than one purchaser JOINT TENANTS
 tenants in common in unequal shares, specify:

GST AMOUNT (optional) The price includes GST of: \$

buyer's agent

Note: Clause 20.15 provides "Where this contract provides for choices, a choice in BLOCK CAPITALS applies unless a different choice is marked."

SIGNING PAGE

VENDOR	PURCHASER
<p>Signed by</p> <p>_____</p> <p>Vendor</p> <p>_____</p> <p>Vendor</p>	<p>Signed by</p> <p>_____</p> <p>Purchaser</p> <p>_____</p> <p>Purchaser</p>
VENDOR (COMPANY)	PURCHASER (COMPANY)
<p>Signed by in accordance with s127(1) of the Corporations Act 2001 by the authorised person(s) whose signature(s) appear(s) below:</p> <p>_____ _____</p> <p>Signature of authorised person Signature of authorised person</p> <p>_____ _____</p> <p>Name of authorised person Name of authorised person</p> <p>_____ _____</p> <p>Office held Office held</p>	<p>Signed by in accordance with s127(1) of the Corporations Act 2001 by the authorised person(s) whose signature(s) appear(s) below:</p> <p>_____ _____</p> <p>Signature of authorised person Signature of authorised person</p> <p>_____ _____</p> <p>Name of authorised person Name of authorised person</p> <p>_____ _____</p> <p>Office held Office held</p>

Choices

- Vendor agrees to accept a **deposit-bond** NO yes
- Nominated *Electronic Lodgment Network (ELN)*** (clause 4) PEXA
-
- Manual transaction** (clause 30) NO yes
 (if yes, vendor must provide further details, including any applicable exemption, in the space below):

Tax information (the parties promise this is correct as far as each party is aware)

- Land tax** is adjustable NO yes
- GST:** Taxable supply NO yes in full yes to an extent
- Margin scheme will be used in making the taxable supply NO yes

This sale is not a taxable supply because (one or more of the following may apply) the sale is:

- not made in the course or furtherance of an enterprise that the vendor carries on (section 9-5(b))
- by a vendor who is neither registered nor required to be registered for GST (section 9-5(d))
- GST-free because the sale is the supply of a going concern under section 38-325
- GST-free because the sale is subdivided farm land or farm land supplied for farming under Subdivision 38-O
- input taxed because the sale is of eligible residential premises (sections 40-65, 40-75(2) and 195-1)

- Purchaser must make an **GSTRW payment** NO yes (if yes, vendor must provide details)
 (GST residential withholding payment)

If the details below are not fully completed at the contract date, the vendor must provide all these details in a separate notice at least 7 days before the date for completion.

GSTRW payment (GST residential withholding payment) – details

Frequently the supplier will be the vendor. However, sometimes further information will be required as to which entity is liable for GST, for example, if the supplier is a partnership, a trust, part of a GST group or a participant in a GST joint venture.

Supplier's name:

Supplier's ABN:

Supplier's GST branch number (if applicable):

Supplier's business address:

Supplier's representative:

Supplier's contact phone number:

Supplier's proportion of **GSTRW payment**:

If more than one supplier, provide the above details for each supplier.

Amount purchaser must pay – price multiplied by the **GSTRW rate** (residential withholding rate): \$

Amount must be paid: AT COMPLETION at another time (specify):

Is any of the consideration not expressed as an amount in money? NO yes

If "yes", the GST inclusive market value of the non-monetary consideration: \$

Other details (including those required by regulation or the ATO forms):

List of Documents

General	Strata or community title (clause 23 of the contract)
<input checked="" type="checkbox"/> 1 property certificate for the land <input checked="" type="checkbox"/> 2 plan of the land <input type="checkbox"/> 3 unregistered plan of the land <input type="checkbox"/> 4 plan of land to be subdivided <input type="checkbox"/> 5 document that is to be lodged with a relevant plan <input checked="" type="checkbox"/> 6 section 10.7(2) planning certificate under Environmental Planning and Assessment Act 1979 <input type="checkbox"/> 7 additional information included in that certificate under section 10.7(5) <input checked="" type="checkbox"/> 8 sewerage infrastructure location diagram (service location print) <input checked="" type="checkbox"/> 9 sewer lines location diagram (sewer service diagram) <input checked="" type="checkbox"/> 10 document that created or may have created an easement, profit à prendre, restriction on use or positive covenant disclosed in this contract <input type="checkbox"/> 11 <i>planning agreement</i> <input type="checkbox"/> 12 section 88G certificate (positive covenant) <input type="checkbox"/> 13 survey report <input type="checkbox"/> 14 building information certificate or building certificate given under <i>legislation</i> <input type="checkbox"/> 15 occupation certificate <input type="checkbox"/> 16 lease (with every relevant memorandum or variation) <input type="checkbox"/> 17 other document relevant to tenancies <input type="checkbox"/> 18 licence benefiting the land <input type="checkbox"/> 19 old system document <input type="checkbox"/> 20 Crown purchase statement of account <input type="checkbox"/> 21 building management statement <input checked="" type="checkbox"/> 22 form of requisitions <input type="checkbox"/> 23 <i>clearance certificate</i> <input type="checkbox"/> 24 land tax certificate	<input checked="" type="checkbox"/> 33 property certificate for strata common property <input checked="" type="checkbox"/> 34 plan creating strata common property <input type="checkbox"/> 35 strata by-laws <input type="checkbox"/> 36 strata development contract <input type="checkbox"/> 37 strata management statement <input type="checkbox"/> 38 strata renewal proposal <input type="checkbox"/> 39 strata renewal plan <input type="checkbox"/> 40 leasehold strata - lease of lot and common property <input type="checkbox"/> 41 property certificate for neighbourhood property <input type="checkbox"/> 42 plan creating neighbourhood property <input type="checkbox"/> 43 neighbourhood development contract <input type="checkbox"/> 44 neighbourhood management statement <input type="checkbox"/> 45 property certificate for precinct property <input type="checkbox"/> 46 plan creating precinct property <input type="checkbox"/> 47 precinct development contract <input type="checkbox"/> 48 precinct management statement <input type="checkbox"/> 49 property certificate for community property <input type="checkbox"/> 50 plan creating community property <input type="checkbox"/> 51 community development contract <input type="checkbox"/> 52 community management statement <input type="checkbox"/> 53 document disclosing a change of by-laws <input type="checkbox"/> 54 document disclosing a change in a development contract or management statement <input type="checkbox"/> 55 document disclosing a change in boundaries <input type="checkbox"/> 56 information certificate (strata) <input type="checkbox"/> 57 information certificate (association) <input type="checkbox"/> 58 document relevant to an exclusive supply network <input type="checkbox"/> 59 disclosure statement - off the plan contract <input type="checkbox"/> 60 other document relevant to the off the plan contract Other <input type="checkbox"/> 61
Home Building Act 1989 <input type="checkbox"/> 25 insurance certificate <input type="checkbox"/> 26 brochure or warning <input type="checkbox"/> 27 evidence of alternative indemnity cover Swimming Pools Act 1992 <input type="checkbox"/> 28 certificate of compliance <input type="checkbox"/> 29 evidence of registration <input type="checkbox"/> 30 relevant occupation certificate <input type="checkbox"/> 31 certificate of non-compliance <input type="checkbox"/> 32 detailed reasons of non-compliance	

HOLDER OF STRATA OR COMMUNITY SCHEME RECORDS – Name, address, email address and telephone number

Area Strata Management
 Suite 2, Level 2/5 George St, North Strathfield NSW 2137
 info@areastrata.com.au
 02 9056 8101

IMPORTANT NOTICE TO VENDORS AND PURCHASERS

Before signing this contract you should ensure that you understand your rights and obligations, some of which are not written in this contract but are implied by law.

WARNING—SMOKE ALARMS

The owners of certain types of buildings and strata lots must have smoke alarms, or in certain cases heat alarms, installed in the building or lot in accordance with regulations under the *Environmental Planning and Assessment Act 1979*. It is an offence not to comply. It is also an offence to remove or interfere with a smoke alarm or heat alarm. Penalties apply.

WARNING—LOOSE-FILL ASBESTOS INSULATION

Before purchasing land that includes residential premises, within the meaning of the *Home Building Act 1989*, Part 8, Division 1A, built before 1985, a purchaser is strongly advised to consider the possibility that the premises may contain loose-fill asbestos insulation, within the meaning of the *Home Building Act 1989*, Part 8, Division 1A. In particular, a purchaser should—

- (a) search the Register required to be maintained under the *Home Building Act 1989*, Part 8, Division 1A, and
- (b) ask the relevant local council whether it holds records showing that the residential premises contain loose-fill asbestos insulation.

For further information about loose-fill asbestos insulation, including areas in which residential premises have been identified as containing loose-fill asbestos insulation, contact NSW Fair Trading.

Cooling off period (purchaser's rights)

- 1** This is the statement required by the *Conveyancing Act 1919*, section 66X. This statement applies to a contract for the sale of residential property.
- 2** **EXCEPT** in the circumstances listed in paragraph 3, the purchaser may rescind the contract before 5pm on—
 - (a) for an off the plan contract—the tenth business day after the day on which the contract was made, or
 - (b) in any other case—the fifth business day after the day on which the contract was made.
- 3** There is **NO COOLING OFF PERIOD**—
 - (a) if, at or before the time the contract is made, the purchaser gives to the vendor, or the vendor's solicitor or agent, a certificate that complies with the Act, section 66W, or
 - (b) if the property is sold by public auction, or
 - (c) if the contract is made on the same day as the property was offered for sale by public auction but passed in, or
 - (d) if the contract is made in consequence of the exercise of an option, other than an option that is void under the Act, section 66ZG.
- 4** A purchaser exercising the right to cool off by rescinding the contract forfeits 0.25% of the purchase price of the property to the vendor.
- 5** The vendor is entitled to recover the forfeited amount from an amount paid by the purchaser as a deposit under the contract. The purchaser is entitled to a refund of any balance.

DISPUTES

If you get into a dispute with the other party, the Law Society and Real Estate Institute encourage you to use informal procedures to resolve the dispute such as negotiation, independent expert appraisal, the Law Society Conveyancing Dispute Resolution Scheme or mediation (for example mediation under the Law Society Mediation Program).

AUCTIONS

Regulations made under the Property and Stock Agents Act 2002 prescribe a number of conditions applying to sales by auction.

WARNINGS

1. Various Acts of Parliament and other matters can affect the rights of the parties to this contract. Some important matters are actions, claims, decisions, licences, notices, orders, proposals or rights of way involving:

<p>Australian Taxation Office County Council Department of Education Department of Planning, Housing and Infrastructure Department of Primary Industries and Regional Development Electricity, gas and telecommunications Homes NSW</p>	<p>Local Council Local Land Services NSW Fair Trading NSW Public Works Owner of adjoining land Privacy Subsidence Advisory NSW Transport agencies Water, sewerage or drainage authority</p>
---	---

If you think that any of these matters affects the property, tell your solicitor.
2. A lease may be affected by the Agricultural Tenancies Act 1990, the Residential Tenancies Act 2010 or the Retail Leases Act 1994.
3. If any purchase money is owing to the Crown, it will become payable before obtaining consent, or if no consent is needed, when the transfer is registered.
4. If a consent to transfer is required under legislation, see clause 27 as to the obligations of the parties.
5. The vendor should continue the vendor's insurance until completion. If the vendor wants to give the purchaser possession before completion, the vendor should first ask the insurer to confirm this will not affect the insurance.
6. Most purchasers will have to pay transfer duty (and, sometimes, if the purchaser is not an Australian citizen, surcharge purchaser duty) on this contract. If a payment is not made on time, interest and penalties may be incurred. More information is available from Revenue NSW.
7. If the purchaser agrees to the release of deposit, the purchaser's right to recover the deposit may stand behind the rights of others (for example the vendor's mortgagee).
8. The purchaser should arrange insurance as appropriate.
9. Some transactions involving personal property may be affected by the Personal Property Securities Act 2009.
10. A purchaser should be satisfied that finance will be available at the time of completing the purchase.
11. The purchaser may have to comply with a foreign resident capital gains withholding payment obligation (even if the vendor is not a foreign resident). If so, this will affect the amount available to the vendor on completion.
12. Purchasers of some residential properties may have to withhold part of the purchase price to be credited towards the GST liability of the vendor. If so, this will also affect the amount available to the vendor. More information is available from the Australian Taxation Office.
13. From 1 July 2026, estate agents, solicitors, licensed conveyancers and other professions who provide a designated service will have regulatory obligations under the Anti-Money Laundering and Counter-Terrorism Financing (AML/CTF) regime. These new obligations include customer due diligence and reporting to AUSTRAC. More details are available from AUSTRAC.

The vendor sells and the purchaser buys the *property* for the price under these provisions instead of Schedule 3 Conveyancing Act 1919, subject to any *legislation* that cannot be excluded.

1 Definitions (a term in italics is a defined term)

1.1	In this contract, these terms (in any form) mean –
<i>adjustment date</i>	the earlier of the giving of possession to the purchaser or completion;
<i>adjustment figures</i>	details of the adjustments to be made to the price under clause 14;
<i>authorised Subscriber</i>	a <i>Subscriber</i> (not being a <i>party's solicitor</i>) named in a notice <i>served</i> by a <i>party</i> as being authorised for the purposes of clause 20.6.8;
<i>bank</i>	the Reserve Bank of Australia or an authorised deposit-taking institution which is a bank, a building society or a credit union;
<i>business day</i>	any day except a bank or public holiday throughout NSW or a Saturday or Sunday;
<i>cheque</i>	a cheque that is not postdated or stale;
<i>clearance certificate</i>	a certificate within the meaning of s14-220 of Schedule 1 to the <i>TA Act</i> , that covers one or more days falling within the period from and including the contract date to completion;
<i>completion time</i>	the time of day at which completion is to occur;
<i>deposit-bond</i>	a deposit bond or guarantee with each of the following approved by the vendor – <ul style="list-style-type: none"> ● the issuer; ● the expiry date (if any); and ● the amount;
<i>depositholder</i>	vendor's agent (or if no vendor's agent is named in this contract, the vendor's <i>solicitor</i> , or if no vendor's <i>solicitor</i> is named in this contract, the buyer's agent);
<i>discharging mortgagee</i>	any discharging mortgagee, chargee, covenant chargee or caveator whose provision of a <i>Digitally Signed</i> discharge of mortgage, discharge of charge or withdrawal of caveat is required in order for unencumbered title to the <i>property</i> to be transferred to the purchaser;
<i>document of title</i>	document relevant to the title or the passing of title;
<i>ECNL</i>	the Electronic Conveyancing National Law (NSW);
<i>electronic document</i>	a dealing as defined in the Real Property Act 1900 which may be created and <i>Digitally Signed</i> in an <i>Electronic Workspace</i> ;
<i>electronic transaction</i>	a <i>Conveyancing Transaction</i> to be conducted for the <i>parties</i> by their legal representatives as <i>Subscribers</i> using an <i>ELN</i> and in accordance with the <i>ECNL</i> and the <i>participation rules</i> ;
<i>electronic transfer</i>	a transfer of land under the Real Property Act 1900 for the <i>property</i> to be prepared and <i>Digitally Signed</i> in the <i>Electronic Workspace</i> established for the purposes of the <i>parties' Conveyancing Transaction</i> ;
<i>FRCGW percentage</i>	the percentage mentioned in s14-200(3)(a) of Schedule 1 to the <i>TA Act</i> (15% as at 1 January 2025);
<i>FRCGW remittance</i>	a remittance which the purchaser must make under s14-200 of Schedule 1 to the <i>TA Act</i> , being the lesser of the <i>FRCGW percentage</i> of the price (inclusive of GST, if any) and the amount specified in a <i>variation served</i> by a <i>party</i> ;
<i>GST Act</i>	A New Tax System (Goods and Services Tax) Act 1999;
<i>GST rate</i>	the rate mentioned in s4 of A New Tax System (Goods and Services Tax Imposition - General) Act 1999 (10% as at 1 July 2000);
<i>GSTRW payment</i>	a payment which the purchaser must make under s14-250 of Schedule 1 to the <i>TA Act</i> (the price multiplied by the <i>GSTRW rate</i>);
<i>GSTRW rate</i>	the rate determined under ss14-250(6), (8) or (9) of Schedule 1 to the <i>TA Act</i> (as at 1 July 2018, usually 7% of the price if the margin scheme applies, 1/11 th if not);
<i>incoming mortgagee</i>	any mortgagee who is to provide finance to the purchaser on the security of the <i>property</i> and to enable the purchaser to pay the whole or part of the price;
<i>legislation</i>	an Act or a by-law, ordinance, regulation or rule made under an Act;
<i>manual transaction</i>	a <i>Conveyancing Transaction</i> in which a dealing forming part of the <i>Lodgment Case</i> at or following completion cannot be <i>Digitally Signed</i> ;
<i>normally</i>	subject to any other provision of this contract;
<i>participation rules</i>	the participation rules as determined by the <i>ECNL</i> ;
<i>party</i>	each of the vendor and the purchaser;
<i>property</i>	the land, the improvements, all fixtures and the inclusions, but not the exclusions;
<i>planning agreement</i>	a valid voluntary agreement within the meaning of s7.4 of the Environmental Planning and Assessment Act 1979 entered into in relation to the <i>property</i> ;
<i>populate</i>	to complete data fields in the <i>Electronic Workspace</i> ;

<i>requisition</i>	an objection, question or requisition (but the term does not include a claim);
<i>rescind</i>	rescind this contract from the beginning;
<i>serve</i>	serve in writing on the other <i>party</i> ;
<i>settlement cheque</i>	an unendorsed <i>cheque</i> made payable to the person to be paid and – <ul style="list-style-type: none"> • issued by a <i>bank</i> and drawn on itself; or • if authorised in writing by the vendor or the vendor's <i>solicitor</i>, some other <i>cheque</i>;
<i>solicitor</i>	in relation to a <i>party</i> , the <i>party's</i> solicitor or licensed conveyancer named in this contract or in a notice <i>served</i> by the <i>party</i> ;
<i>TA Act</i>	Taxation Administration Act 1953;
<i>terminate</i>	terminate this contract for breach;
<i>title data</i>	the details of the title to the <i>property</i> made available to the <i>Electronic Workspace</i> by the <i>Land Registry</i> ;
<i>variation</i>	a variation made under s14-235 of Schedule 1 to the <i>TA Act</i> ;
<i>within</i>	in relation to a period, at any time before or during the period; and
<i>work order</i>	a valid direction, notice or order that requires work to be done or money to be spent on or in relation to the <i>property</i> or any adjoining footpath or road (but the term does not include a notice under s22E of the Swimming Pools Act 1992 or clause 20 of the Swimming Pools Regulation 2018).

- 1.2 Words and phrases used in this contract (italicised and in Title Case, such as *Conveyancing Transaction*, *Digitally Sign*, *Electronic Workspace*, *ELN*, *ELNO*, *Land Registry*, *Lodgment Case* and *Subscriber*) have the meanings given in the *participation rules*.

2 Deposit and other payments before completion

- 2.1 The purchaser must pay the deposit to the *depositholder* as stakeholder.
- 2.2 *Normally*, the purchaser must pay the deposit on the making of this contract, and this time is essential.
- 2.3 If this contract requires the purchaser to pay any of the deposit by a later time, that time is also essential.
- 2.4 The purchaser can pay any of the deposit by –
- 2.4.1 giving cash (up to \$2,000) to the *depositholder*;
- 2.4.2 unconditionally giving a *cheque* to the *depositholder* or to the vendor, vendor's agent or vendor's *solicitor* for sending to the *depositholder*; or
- 2.4.3 electronic funds transfer to the *depositholder's* nominated account and, if requested by the vendor or the *depositholder*, providing evidence of that transfer.
- 2.5 The vendor can *terminate* if –
- 2.5.1 any of the deposit is not paid on time;
- 2.5.2 a *cheque* for any of the deposit is not honoured on presentation; or
- 2.5.3 a payment under clause 2.4.3 is not received in the *depositholder's* nominated account by 5.00 pm on the third *business day* after the time for payment.
- This right to *terminate* is lost as soon as the deposit is paid in full.
- 2.6 If the vendor accepts a *deposit-bond* for the deposit, clauses 2.1 to 2.5 do not apply.
- 2.7 If the vendor accepts a *deposit-bond* for part of the deposit, clauses 2.1 to 2.5 apply only to the balance.
- 2.8 If any of the deposit or of the balance of the price is paid before completion to the vendor or as the vendor directs, it is a charge on the land in favour of the purchaser until *termination* by the vendor or completion, subject to any existing right.
- 2.9 If each *party* tells the *depositholder* that the deposit is to be invested, the *depositholder* is to invest the deposit (at the risk of the *party* who becomes entitled to it) with a *bank*, in an interest-bearing account in NSW, payable at call, with interest to be reinvested, and pay the interest to the *parties* equally, after deduction of all proper government taxes and financial institution charges and other charges.

3 Deposit-bond

- 3.1 This clause applies only if the vendor accepts a *deposit-bond* for the deposit (or part of it).
- 3.2 The purchaser must provide the *deposit-bond* to the vendor's *solicitor* (or if no solicitor the *depositholder*) at or before the making of this contract and this time is essential.
- 3.3 If the *deposit-bond* has an expiry date and completion does not occur by the date which is 14 days before the expiry date, the purchaser must *serve* a replacement *deposit-bond* at least 7 days before the expiry date. The time for service is essential.
- 3.4 The vendor must approve a replacement *deposit-bond* if –
- 3.4.1 it is from the same issuer and for the same amount as the earlier *deposit-bond*; and
- 3.4.2 it has an expiry date at least three months after its date of issue.
- 3.5 A breach of clauses 3.2 or 3.3 entitles the vendor to *terminate*. The right to *terminate* is lost as soon as –
- 3.5.1 the purchaser *serves* a replacement *deposit-bond*; or
- 3.5.2 the deposit is paid in full under clause 2.
- 3.6 Clauses 3.3 and 3.4 can operate more than once.

- 3.7 If the purchaser *serves* a replacement *deposit-bond*, the vendor must *serve* the earlier *deposit-bond*.
- 3.8 The amount of any *deposit-bond* does not form part of the price for the purposes of clause 16.5.
- 3.9 The vendor must give the purchaser any original *deposit-bond* –
- 3.9.1 on completion; or
- 3.9.2 if this contract is *rescinded*.
- 3.10 If this contract is *terminated* by the vendor –
- 3.10.1 *normally*, the vendor can immediately demand payment from the issuer of the *deposit-bond*; or
- 3.10.2 if the purchaser *serves* prior to *termination* a notice disputing the vendor's right to *terminate*, the vendor must forward any original *deposit-bond* (or its proceeds if called up) to the *depositholder* as stakeholder.
- 3.11 If this contract is *terminated* by the purchaser –
- 3.11.1 *normally*, the vendor must give the purchaser any original *deposit-bond*; or
- 3.11.2 if the vendor *serves* prior to *termination* a notice disputing the purchaser's right to *terminate*, the vendor must forward any original *deposit-bond* (or its proceeds if called up) to the *depositholder* as stakeholder.
- 4 Electronic transaction**
- 4.1 This *Conveyancing Transaction* is to be conducted as an *electronic transaction* unless –
- 4.1.1 the contract says this transaction is a *manual transaction*, giving the reason, or
- 4.1.2 a *party serves* a notice stating why the transaction is a *manual transaction*, in which case the *parties* do not have to complete earlier than 14 days after *service* of the notice, and clause 21.3 does not apply to this provision,
- and in both cases clause 30 applies.
- 4.2 If, because of clause 4.1.2, this *Conveyancing Transaction* is to be conducted as a *manual transaction* –
- 4.2.1 each *party* must –
- bear equally any disbursements or fees; and
 - otherwise bear that *party's* own costs;
- incurred because this *Conveyancing Transaction* was to be conducted as an *electronic transaction*; and
- 4.2.2 if a *party* has paid all of a disbursement or fee which, by reason of this clause, is to be borne equally by the *parties*, that amount must be adjusted under clause 14.
- 4.3 The *parties* must conduct the *electronic transaction* –
- 4.3.1 in accordance with the *participation rules* and the *ECNL*; and
- 4.3.2 using the nominated *ELN*, unless the *parties* otherwise agree. This clause 4.3.2 does not prevent a *party* using an *ELN* which can interoperate with the nominated *ELN*.
- 4.4 A *party* must pay the fees and charges payable by that *party* to the *ELNO* and the *Land Registry*.
- 4.5 *Normally*, the vendor must *within 7 days* of the contract date create and *populate* an *Electronic Workspace* with *title data* and the date for completion, and invite the purchaser to the *Electronic Workspace*.
- 4.6 If the vendor has not created an *Electronic Workspace* in accordance with clause 4.5, the purchaser may create and *populate* an *Electronic Workspace* and, if it does so, the purchaser must invite the vendor to the *Electronic Workspace*.
- 4.7 The *parties* must, as applicable to their role in the *Conveyancing Transaction* and the steps taken under clauses 4.5 or 4.6 –
- 4.7.1 promptly join the *Electronic Workspace* after receipt of an invitation;
- 4.7.2 create and *populate* an *electronic transfer*;
- 4.7.3 invite any *discharging mortgagee* or *incoming mortgagee* to join the *Electronic Workspace*; and
- 4.7.4 *populate* the *Electronic Workspace* with a nominated *completion time*.
- 4.8 If the transferee in the *electronic transfer* is not the purchaser, the purchaser must give the vendor a direction signed by the purchaser personally for that transfer.
- 4.9 The vendor can require the purchaser to include a covenant or easement in the *electronic transfer* only if this contract contains the wording of the proposed covenant or easement, and a description of the land burdened and benefited.
- 4.10 If the purchaser must make a *GSTRW payment* or an *FRCGW remittance*, the purchaser must *populate* the *Electronic Workspace* with the payment details for the *GSTRW payment* or *FRCGW remittance* payable to the Deputy Commissioner of Taxation at least 2 *business days* before the date for completion.
- 4.11 Before completion, the *parties* must ensure that –
- 4.11.1 all *electronic documents* which a *party* must *Digitally Sign* to complete the *electronic transaction* are *populated* and *Digitally Signed*;
- 4.11.2 all certifications required by the *ECNL* are properly given; and
- 4.11.3 they do everything else in the *Electronic Workspace* which that *party* must do to enable the *electronic transaction* to proceed to completion.
- 4.12 If the computer systems of any of the *Land Registry*, the *ELNO*, Revenue NSW or the Reserve Bank of Australia are inoperative for any reason at the *completion time* agreed by the *parties*, a failure to complete this contract for that reason is not a default under this contract on the part of either *party*.

- 4.13 If the computer systems of the *Land Registry* are inoperative for any reason at the *completion time* agreed by the *parties*, and the *parties* choose that financial settlement is to occur despite this, then on financial settlement occurring –
- 4.13.1 all *electronic documents Digitally Signed* by the vendor and any discharge of mortgage, withdrawal of caveat or other *electronic document* forming part of the *Lodgment Case* for the *electronic transaction* are taken to have been unconditionally and irrevocably delivered to the purchaser or the purchaser's mortgagee at the time of financial settlement together with the right to deal with the land; and
- 4.13.2 the vendor is taken to have no legal or equitable interest in the *property*.
- 4.14 If the *parties* do not agree about the delivery before completion of one or more documents or things that cannot be delivered through the *Electronic Workspace*, the *party* required to deliver the documents or things –
- 4.14.1 holds them on completion in escrow for the benefit of; and
- 4.14.2 must immediately after completion deliver the documents or things to, or as directed by; the *party* entitled to them.

5 Requisitions

- 5.1 If a form of *requisitions* is attached to this contract, the purchaser is taken to have made those *requisitions*.
- 5.2 If the purchaser is or becomes entitled to make any other *requisition*, the purchaser can make it only by *servicing* it –
- 5.2.1 if it arises out of this contract or it is a general question about the *property* or title - *within 21 days* after the contract date;
- 5.2.2 if it arises out of anything *served* by the vendor - *within 21 days* after the later of the contract date and that *service*; and
- 5.2.3 in any other case - *within a reasonable time*.

6 Error or misdescription

- 6.1 *Normally*, the purchaser can (but only before completion) claim compensation for an error or misdescription in this contract (as to the *property*, the title or anything else and whether substantial or not).
- 6.2 This clause applies even if the purchaser did not take notice of or rely on anything in this contract containing or giving rise to the error or misdescription.
- 6.3 However, this clause does not apply to the extent the purchaser knows the true position.

7 Claims by purchaser

- Normally*, the purchaser can make a claim (including a claim under clause 6) before completion only by *servicing* it with a statement of the amount claimed, and if the purchaser makes one or more claims before completion –
- 7.1 the vendor can *rescind* if in the case of claims that are not claims for delay –
- 7.1.1 the total amount claimed exceeds 5% of the price;
- 7.1.2 the vendor *serves* notice of intention to *rescind*; and
- 7.1.3 the purchaser does not *serve* notice waiving the claims *within 14 days* after that *service*; and
- 7.2 if the vendor does not *rescind*, the *parties* must complete and if this contract is completed –
- 7.2.1 the lesser of the total amount claimed and 10% of the price must be paid out of the price to and held by the *depositholder* until the claims are finalised or lapse;
- 7.2.2 the amount held is to be invested in accordance with clause 2.9;
- 7.2.3 the claims must be finalised by an arbitrator appointed by the *parties* or, if an appointment is not made *within 1 month* of completion, by an arbitrator appointed by the President of the Law Society at the request of a *party* (in the latter case the *parties* are bound by the terms of the Conveyancing Arbitration Rules approved by the Law Society as at the date of the appointment);
- 7.2.4 the purchaser is not entitled, in respect of the claims, to more than the total amount claimed and the costs of the purchaser;
- 7.2.5 net interest on the amount held must be paid to the *parties* in the same proportion as the amount held is paid; and
- 7.2.6 if the *parties* do not appoint an arbitrator and neither *party* requests the President to appoint an arbitrator *within 3 months* after completion, the claims lapse and the amount belongs to the vendor.

8 Vendor's rights and obligations

- 8.1 The vendor can *rescind* if –
- 8.1.1 the vendor is, on reasonable grounds, unable or unwilling to comply with a *requisition*;
- 8.1.2 the vendor *serves* a notice of intention to *rescind* that specifies the *requisition* and those grounds; and
- 8.1.3 the purchaser does not *serve* a notice waiving the *requisition within 14 days* after that *service*.

- 8.2 If the vendor does not comply with this contract (or a notice under or relating to it) in an essential respect, the purchaser can *terminate* by *servicing* a notice. After the *termination* –
- 8.2.1 the purchaser can recover the deposit and any other money paid by the purchaser under this contract;
- 8.2.2 the purchaser can sue the vendor to recover damages for breach of contract; and
- 8.2.3 if the purchaser has been in possession a *party* can claim for a reasonable adjustment.

9 Purchaser's default

If the purchaser does not comply with this contract (or a notice under or relating to it) in an essential respect, the vendor can *terminate* by *servicing* a notice. After the *termination* the vendor can –

- 9.1 keep or recover the deposit (to a maximum of 10% of the price);
- 9.2 hold any other money paid by the purchaser under this contract as security for anything recoverable under this clause –
- 9.2.1 for 12 months after the *termination*; or
- 9.2.2 if the vendor commences proceedings under this clause *within* 12 months, until those proceedings are concluded; and
- 9.3 sue the purchaser either –
- 9.3.1 where the vendor has resold the *property* under a contract made *within* 12 months after the *termination*, to recover –
- the deficiency on resale (with credit for any of the deposit kept or recovered and after allowance for any capital gains tax or goods and services tax payable on anything recovered under this clause); and
 - the reasonable costs and expenses arising out of the purchaser's non-compliance with this contract or the notice and of resale and any attempted resale; or
- 9.3.2 to recover damages for breach of contract.

10 Restrictions on rights of purchaser

- 10.1 The purchaser cannot make a claim or *requisition* or *rescind* or *terminate* in respect of –
- 10.1.1 the ownership or location of any fence as defined in the Dividing Fences Act 1991;
- 10.1.2 a service for the *property* being a joint service or passing through another property, or any service for another property passing through the *property* ('service' includes air, communication, drainage, electricity, garbage, gas, oil, radio, sewerage, telephone, television or water service);
- 10.1.3 a wall being or not being a party wall in any sense of that term or the *property* being affected by an easement for support or not having the benefit of an easement for support;
- 10.1.4 any change in the *property* due to fair wear and tear before completion;
- 10.1.5 a promise, representation or statement about this contract, the *property* or the title, not set out or referred to in this contract;
- 10.1.6 a condition, exception, reservation or restriction in a Crown grant;
- 10.1.7 the existence of any authority or licence to explore or prospect for gas, minerals or petroleum;
- 10.1.8 any easement or restriction on use the substance of either of which is disclosed in this contract or any non-compliance with the easement or restriction on use; or
- 10.1.9 anything the substance of which is disclosed in this contract (except a caveat, charge, mortgage, priority notice or writ).
- 10.2 The purchaser cannot *rescind* or *terminate* only because of a defect in title to or quality of the inclusions.
- 10.3 *Normally*, the purchaser cannot make a claim or *requisition* or *rescind* or *terminate* or require the vendor to change the nature of the title disclosed in this contract (for example, to remove a caution evidencing qualified title, or to lodge a plan of survey as regards limited title).

11 Compliance with work orders

- 11.1 *Normally*, the vendor must by completion comply with a *work order* made on or before the contract date and if this contract is completed the purchaser must comply with any other *work order*.
- 11.2 If the purchaser complies with a *work order*, and this contract is *rescinded* or *terminated*, the vendor must pay the expense of compliance to the purchaser.

12 Certificates and inspections

The vendor must do whatever is reasonably necessary to enable the purchaser, subject to the rights of any tenant –

- 12.1 to have the *property* inspected to obtain any certificate or report reasonably required;
- 12.2 to apply (if necessary in the name of the vendor) for –
- 12.2.1 any certificate that can be given in respect of the *property* under *legislation*; or
- 12.2.2 a copy of any approval, certificate, consent, direction, notice or order in respect of the *property* given under *legislation*, even if given after the contract date; and
- 12.3 to make 1 inspection of the *property* in the 3 days before a time appointed for completion.

13 Goods and services tax (GST)

- 13.1 Terms used in this clause which are not defined elsewhere in this contract and have a defined meaning in the *GST Act* have the same meaning in this clause.
- 13.2 *Normally*, if a *party* must pay the price or any other amount to the other *party* under this contract, GST is not to be added to the price or amount.
- 13.3 If under this contract a *party* must make an adjustment or payment for an expense of another party or pay an expense payable by or to a third party (for example, under clauses 14 or 20.7), the *party* must adjust or pay on completion any GST added to or included in the expense, but –
- 13.3.1 the amount of the expense must be reduced to the extent the party receiving the adjustment or payment (or the representative member of a GST group of which that party is a member) is entitled to an input tax credit for the expense; and
- 13.3.2 if the adjustment or payment under this contract is consideration for a taxable supply, an amount for GST must be added at the *GST rate*.
- 13.4 If this contract says this sale is the supply of a going concern –
- 13.4.1 the *parties* agree the supply of the *property* is a supply of a going concern;
- 13.4.2 the vendor must, between the contract date and completion, carry on the enterprise conducted on the land in a proper and business-like way;
- 13.4.3 if the purchaser is not registered by the date for completion, the *parties* must complete and the purchaser must pay on completion, in addition to the price, an amount being the price multiplied by the *GST rate* ("the retention sum"). The retention sum is to be held by the *depositholder* and dealt with as follows –
- if *within* 3 months of completion the purchaser *serves* a letter from the Australian Taxation Office stating the purchaser is registered with a date of effect of registration on or before completion, the *depositholder* is to pay the retention sum to the purchaser; but
 - if the purchaser does not *serve* that letter *within* 3 months of completion, the *depositholder* is to pay the retention sum to the vendor; and
- 13.4.4 if the vendor, despite clause 13.4.1, *serves* a letter from the Australian Taxation Office stating the vendor has to pay GST on the supply, the purchaser must pay to the vendor on demand the amount of GST assessed.
- 13.5 *Normally*, the vendor promises the margin scheme will not apply to the supply of the *property*.
- 13.6 If this contract says the margin scheme is to apply in making the taxable supply, the *parties* agree that the margin scheme is to apply to the sale of the *property*.
- 13.7 If this contract says the sale is not a taxable supply –
- 13.7.1 the purchaser promises that the *property* will not be used and represents that the purchaser does not intend the *property* (or any part of the *property*) to be used in a way that could make the sale a taxable supply to any extent; and
- 13.7.2 the purchaser must pay the vendor on completion in addition to the price an amount calculated by multiplying the price by the *GST rate* if this sale is a taxable supply to any extent because of –
- a breach of clause 13.7.1; or
 - something else known to the purchaser but not the vendor.
- 13.8 If this contract says this sale is a taxable supply in full and does not say the margin scheme applies to the *property*, the vendor must pay the purchaser on completion an amount of one-eleventh of the price if –
- 13.8.1 this sale is not a taxable supply in full; or
- 13.8.2 the margin scheme applies to the *property* (or any part of the *property*).
- 13.9 If this contract says this sale is a taxable supply to an extent –
- 13.9.1 clause 13.7.1 does not apply to any part of the *property* which is identified as being a taxable supply; and
- 13.9.2 the payments mentioned in clauses 13.7 and 13.8 are to be recalculated by multiplying the relevant payment by the proportion of the price which represents the value of that part of the *property* to which the clause applies (the proportion to be expressed as a number between 0 and 1). Any evidence of value must be obtained at the expense of the vendor.
- 13.10 *Normally*, on completion the vendor must give the recipient of the supply a tax invoice for any taxable supply by the vendor by or under this contract.
- 13.11 The vendor does not have to give the purchaser a tax invoice if the margin scheme applies to a taxable supply.
- 13.12 If the vendor is liable for GST on rents or profits due to issuing an invoice or receiving consideration before completion, any adjustment of those amounts must exclude an amount equal to the vendor's GST liability.
- 13.13 If the vendor *serves* details of a *GSTRW payment* which the purchaser must make, the purchaser does not have to complete earlier than 5 *business days* after that *service* and clause 21.3 does not apply to this provision.
- 13.14 If the purchaser must make a *GSTRW payment* the purchaser must, at least 2 *business days* before the date for completion, *serve* evidence of submission of a *GSTRW payment* notification form to the Australian Taxation Office by the purchaser or, if a direction under either clause 4.8 or clause 30.4 has been given, by the transferee named in the transfer the subject of that direction.

14 Adjustments

- 14.1 *Normally*, the vendor is entitled to the rents and profits and will be liable for all rates, water, sewerage and drainage service and usage charges, land tax, levies and all other periodic outgoings up to and including the *adjustment date* after which the purchaser will be entitled and liable.
- 14.2 The *parties* must make any necessary adjustment on completion, and –
- 14.2.1 the purchaser must provide the vendor with *adjustment figures* at least 2 *business days* before the date for completion; and
- 14.2.2 the vendor must confirm the *adjustment figures* at least 1 *business day* before the date for completion.
- 14.3 If an amount that is adjustable under this contract has been reduced under *legislation*, the *parties* must on completion adjust the reduced amount.
- 14.4 The *parties* must not adjust surcharge land tax (as defined in the Land Tax Act 1956) but must adjust any other land tax for the year current at the *adjustment date* –
- 14.4.1 only if land tax has been paid or is payable for the year (whether by the vendor or by a predecessor in title) and this contract says that land tax is adjustable;
- 14.4.2 by adjusting the amount that would have been payable if at the start of the year –
- the person who owned the land owned no other land;
 - the land was not subject to a special trust or owned by a non-concessional company; and
 - if the land (or part of it) had no separate taxable value, by calculating its separate taxable value on a proportional area basis.
- 14.5 The *parties* must not adjust any first home buyer choice property tax.
- 14.6 If any other amount that is adjustable under this contract relates partly to the land and partly to other land, the *parties* must adjust it on a proportional area basis.
- 14.7 If on completion the last bill for a water, sewerage or drainage usage charge is for a period ending before the *adjustment date*, the vendor is liable for an amount calculated by dividing the bill by the number of days in the period then multiplying by the number of unbilled days up to and including the *adjustment date*.
- 14.8 The vendor is liable for any amount recoverable for work started on or before the contract date on the *property* or any adjoining footpath or road.

15 Date for completion

The *parties* must complete by the date for completion and, if they do not, a *party* can serve a notice to complete if that *party* is otherwise entitled to do so.

16 Completion

• Vendor

- 16.1 *Normally*, on completion the vendor must cause the legal title to the *property* (being the estate disclosed in this contract) to pass to the purchaser free of any charge, mortgage or other interest, subject to any necessary registration.
- 16.2 The legal title to the *property* does not pass before completion.
- 16.3 If the vendor gives the purchaser a document (other than the transfer) that needs to be lodged for registration, the vendor must pay the lodgment fee to the purchaser.
- 16.4 If a *party* serves a land tax certificate showing a charge on any of the land, by completion the vendor must do all things and pay all money required so that the charge is no longer effective against the land.

• Purchaser

- 16.5 On completion the purchaser must pay to the vendor –
- 16.5.1 the price less any –
- deposit paid;
 - *FRCGW remittance* payable;
 - *GSTRW payment*; and
 - amount payable by the vendor to the purchaser under this contract; and
- 16.5.2 any other amount payable by the purchaser under this contract.
- 16.6 If any of the deposit is not covered by a *deposit-bond*, at least 1 *business day* before the date for completion the purchaser must give the vendor an order signed by the purchaser authorising the *depositholder* to account to the vendor for the deposit, to be held by the vendor in escrow until completion.
- 16.7 On completion the deposit belongs to the vendor.

17 Possession

- 17.1 *Normally*, the vendor must give the purchaser vacant possession of the *property* on completion.
- 17.2 The vendor does not have to give vacant possession if –
- 17.2.1 this contract says that the sale is subject to existing tenancies; and
- 17.2.2 the contract discloses the provisions of the tenancy (for example, by attaching a copy of the lease and any relevant memorandum or variation).
- 17.3 *Normally*, the purchaser can claim compensation (before or after completion) or *rescind* if any of the land is affected by a protected tenancy (a tenancy affected by Schedule 2, Part 7 of the Residential Tenancies Act 2010).

18 Possession before completion

- 18.1 This clause applies only if the vendor gives the purchaser possession of the *property* before completion.
- 18.2 The purchaser must not before completion –
- 18.2.1 let or part with possession of any of the *property*;
 - 18.2.2 make any change or structural alteration or addition to the *property*; or
 - 18.2.3 contravene any agreement between the *parties* or any direction, document, *legislation*, notice or order affecting the *property*.
- 18.3 The purchaser must until completion –
- 18.3.1 keep the *property* in good condition and repair having regard to its condition at the giving of possession; and
 - 18.3.2 allow the vendor or the vendor's authorised representative to enter and inspect it at all reasonable times.
- 18.4 The risk as to damage to the *property* passes to the purchaser immediately after the purchaser enters into possession.
- 18.5 If the purchaser does not comply with this clause, then without affecting any other right of the vendor –
- 18.5.1 the vendor can before completion, without notice, remedy the non-compliance; and
 - 18.5.2 if the vendor pays the expense of doing this, the purchaser must pay it to the vendor with interest at the rate prescribed under s101 Civil Procedure Act 2005.
- 18.6 If this contract is *rescinded* or *terminated* the purchaser must immediately vacate the *property*.
- 18.7 If the *parties* or their *solicitors* on their behalf do not agree in writing to a fee or rent, none is payable.

19 Rescission of contract

- 19.1 If this contract expressly gives a *party* a right to *rescind*, the *party* can exercise the right –
- 19.1.1 only by *servicing* a notice before completion; and
 - 19.1.2 in spite of any making of a claim or *requisition*, any attempt to satisfy a claim or *requisition*, any arbitration, litigation, mediation or negotiation or any giving or taking of possession.
- 19.2 *Normally*, if a *party* exercises a right to *rescind* expressly given by this contract or any *legislation* –
- 19.2.1 the deposit and any other money paid by the purchaser under this contract must be refunded;
 - 19.2.2 a *party* can claim for a reasonable adjustment if the purchaser has been in possession;
 - 19.2.3 a *party* can claim for damages, costs or expenses arising out of a breach of this contract; and
 - 19.2.4 a *party* will not otherwise be liable to pay the other *party* any damages, costs or expenses.

20 Miscellaneous

- 20.1 The *parties* acknowledge that anything stated in this contract to be attached was attached to this contract by the vendor before the purchaser signed it and is part of this contract.
- 20.2 Anything attached to this contract is part of this contract.
- 20.3 An area, bearing or dimension in this contract is only approximate.
- 20.4 If a *party* consists of 2 or more persons, this contract benefits and binds them separately and together.
- 20.5 A *party's solicitor* can receive any amount payable to the *party* under this contract or direct in writing that it is to be paid to another person.
- 20.6 A document under or relating to this contract is –
- 20.6.1 signed by a *party* if it is signed by the *party* or the *party's solicitor* (apart from a direction under clause 4.8 or clause 30.4);
 - 20.6.2 *served* if it is *served* by the *party* or the *party's solicitor*;
 - 20.6.3 *served* if it is *served* on the *party's solicitor*, even if the *party* has died or any of them has died;
 - 20.6.4 *served* if it is *served* in any manner provided in s170 of the Conveyancing Act 1919;
 - 20.6.5 *served* if it is sent by email or fax to the *party's solicitor*, unless in either case it is not received;
 - 20.6.6 *served* on a person if it (or a copy of it) comes into the possession of the person;
 - 20.6.7 *served* at the earliest time it is *served*, if it is *served* more than once; and
 - 20.6.8 *served* if it is provided to or by the *party's solicitor* or an *authorised Subscriber* by means of an *Electronic Workspace* created under clause 4. However, this does not apply to a notice making an obligation essential, or a notice of *rescission* or *termination*.
- 20.7 An obligation to pay an expense of another *party* of doing something is an obligation to pay –
- 20.7.1 if the *party* does the thing personally - the reasonable cost of getting someone else to do it; or
 - 20.7.2 if the *party* pays someone else to do the thing - the amount paid, to the extent it is reasonable.
- 20.8 Rights under clauses 4, 11, 13, 14, 17, 24, 30 and 31 continue after completion, whether or not other rights continue.
- 20.9 The vendor does not promise, represent or state that the purchaser has any cooling off rights.
- 20.10 The vendor does not promise, represent or state that any attached survey report is accurate or current.
- 20.11 A reference to any *legislation* (including any percentage or rate specified in *legislation*) is also a reference to any corresponding later *legislation*.
- 20.12 Each *party* must do whatever is necessary after completion to carry out the *party's* obligations under this contract.
- 20.13 Neither taking possession nor *servicing* a transfer of itself implies acceptance of the *property* or the title.

- 20.14 The details and information provided in this contract (for example, on pages 1 - 4) are, to the extent of each *party's* knowledge, true, and are part of this contract.
- 20.15 Where this contract provides for choices, a choice in BLOCK CAPITALS applies unless a different choice is marked.
- 20.16 Each *party* consents to –
- 20.16.1 any *party* signing this contract electronically; and
- 20.16.2 the making of this contract by the exchange of counterparts delivered by email, or by such other electronic means as may be agreed by the *parties*.
- 20.17 Each *party* agrees that electronic signing by a *party* identifies that *party* and indicates that *party's* intention to be bound by this contract.

21 Time limits in these provisions

- 21.1 If the time for something to be done or to happen is not stated in these provisions, it is a reasonable time.
- 21.2 If there are conflicting times for something to be done or to happen, the latest of those times applies.
- 21.3 The time for one thing to be done or to happen does not extend the time for another thing to be done or to happen.
- 21.4 If the time for something to be done or to happen is the 29th, 30th or 31st day of a month, and the day does not exist, the time is instead the last day of the month.
- 21.5 If the time for something to be done or to happen is a day that is not a *business day*, the time is extended to the next *business day*, except in the case of clauses 2 and 3.2.
- 21.6 *Normally*, the time by which something must be done is fixed but not essential.

22 Foreign Acquisitions and Takeovers Act 1975

- 22.1 The purchaser promises that the Commonwealth Treasurer cannot prohibit and has not prohibited the transfer under the Foreign Acquisitions and Takeovers Act 1975.
- 22.2 This promise is essential and a breach of it entitles the vendor to *terminate*.

23 Strata or community title

• Definitions and modifications

- 23.1 This clause applies only if the land (or part of it) is a lot in a strata, neighbourhood, precinct or community scheme (or on completion is to be a lot in a scheme of that kind).
- 23.2 In this contract –
- 23.2.1 'change', in relation to a scheme, means –
- a registered or registrable change from by-laws set out in this contract;
 - a change from a development contract or management statement set out in this contract; or
 - a change in the boundaries of common property;
- 23.2.2 'common property' includes association property for the scheme or any higher scheme;
- 23.2.3 'contribution' includes an amount payable under a by-law;
- 23.2.4 'information certificate' includes a certificate under s184 Strata Schemes Management Act 2015 and s174 Community Land Management Act 2021;
- 23.2.5 'interest notice' includes a strata interest notice under s22 Strata Schemes Management Act 2015 and an association interest notice under s20 Community Land Management Act 2021;
- 23.2.6 'normal expenses', in relation to an owners corporation for a scheme, means normal operating expenses usually payable from the administrative fund of an owners corporation for a scheme of the same kind;
- 23.2.7 'owners corporation' means the owners corporation or the association for the scheme or any higher scheme;
- 23.2.8 'the *property*' includes any interest in common property for the scheme associated with the lot; and
- 23.2.9 'special expenses', in relation to an owners corporation, means its actual, contingent or expected expenses, except to the extent they are –
- normal expenses;
 - due to fair wear and tear;
 - disclosed in this contract; or
 - covered by moneys held in the capital works fund.
- 23.3 Clauses 11, 14.8 and 18.4 do not apply to an obligation of the owners corporation, or to property insurable by it.
- 23.4 Clauses 14.4.2 and 14.6 apply but on a unit entitlement basis instead of an area basis.
- ### • Adjustments and liability for expenses
- 23.5 The *parties* must adjust under clause 14.1 –
- 23.5.1 a regular periodic contribution;
- 23.5.2 a contribution which is not a regular periodic contribution but is disclosed in this contract; and
- 23.5.3 on a unit entitlement basis, any amount paid by the vendor for a normal expense of the owners corporation to the extent the owners corporation has not paid the amount to the vendor.

- 23.6 If a contribution is not a regular periodic contribution and is not disclosed in this contract –
- 23.6.1 the vendor is liable for it if it was determined on or before the contract date, even if it is payable by instalments; and
- 23.6.2 the purchaser is liable for all contributions determined after the contract date.
- 23.7 The vendor must pay or allow to the purchaser on completion the amount of any unpaid contributions for which the vendor is liable under clause 23.6.1.
- 23.8 *Normally*, the purchaser cannot make a claim or *requisition* or *rescind* or *terminate* in respect of –
- 23.8.1 an existing or future actual, contingent or expected expense of the owners corporation;
- 23.8.2 a proportional unit entitlement of the lot or a relevant lot or former lot, apart from a claim under clause 6; or
- 23.8.3 a past or future change in the scheme or a higher scheme.
- 23.9 However, the purchaser can *rescind* if –
- 23.9.1 the special expenses of the owners corporation at the later of the contract date and the creation of the owners corporation when calculated on a unit entitlement basis (and, if more than one lot or a higher scheme is involved, added together), less any contribution paid by the vendor, are more than 1% of the price;
- 23.9.2 in the case of the lot or a relevant lot or former lot in a higher scheme, a proportional unit entitlement for the lot is disclosed in this contract but the lot has a different proportional unit entitlement at the contract date or at any time before completion;
- 23.9.3 a change before the contract date or before completion in the scheme or a higher scheme materially prejudices the purchaser and is not disclosed in this contract; or
- 23.9.4 a resolution is passed by the owners corporation before the contract date or before completion to give to the owners in the scheme for their consideration a strata renewal plan that has not lapsed at the contract date and there is not attached to this contract a strata renewal proposal or the strata renewal plan.
- **Notices, certificates and inspections**
- 23.10 Before completion, the purchaser must *serve* a copy of an interest notice addressed to the owners corporation and signed by the purchaser.
- 23.11 After completion, the purchaser must insert the date of completion in the interest notice and send it to the owners corporation.
- 23.12 The vendor can complete and send the interest notice as agent for the purchaser.
- 23.13 The vendor must *serve* at least 7 days before the date for completion, an information certificate for the lot, the scheme or any higher scheme which relates to a period in which the date for completion falls.
- 23.14 The purchaser does not have to complete earlier than 7 days after *service* of the information certificate and clause 21.3 does not apply to this provision. On completion the purchaser must pay the vendor the prescribed fee for the information certificate.
- 23.15 The vendor authorises the purchaser to apply for the purchaser's own information certificate.
- 23.16 The vendor authorises the purchaser to apply for and make an inspection of any record or other document in the custody or control of the owners corporation or relating to the scheme or any higher scheme.
- **Meetings of the owners corporation**
- 23.17 If a general meeting of the owners corporation is convened before completion –
- 23.17.1 if the vendor receives notice of it, the vendor must immediately notify the purchaser of it; and
- 23.17.2 after the expiry of any cooling off period, the purchaser can require the vendor to appoint the purchaser (or the purchaser's nominee) to exercise any voting rights of the vendor in respect of the lot at the meeting.

24 Tenancies

- 24.1 If a tenant has not made a payment for a period preceding or current at the *adjustment date* –
- 24.1.1 for the purposes of clause 14.2, the amount is to be treated as if it were paid; and
- 24.1.2 the purchaser assigns the debt to the vendor on completion and will if required give a further assignment at the vendor's expense.
- 24.2 If a tenant has paid in advance of the *adjustment date* any periodic payment in addition to rent, it must be adjusted as if it were rent for the period to which it relates.
- 24.3 If the *property* is to be subject to a tenancy on completion or is subject to a tenancy on completion –
- 24.3.1 the vendor authorises the purchaser to have any accounting records relating to the tenancy inspected and audited and to have any other document relating to the tenancy inspected;
- 24.3.2 the vendor must *serve* any information about the tenancy reasonably requested by the purchaser before or after completion; and
- 24.3.3 *normally*, the purchaser can claim compensation (before or after completion) if –
- a disclosure statement required by the Retail Leases Act 1994 was not given when required;
 - such a statement contained information that was materially false or misleading;
 - a provision of the lease is not enforceable because of a non-disclosure in such a statement; or
 - the lease was entered into in contravention of the Retail Leases Act 1994.

- 24.4 If the *property* is subject to a tenancy on completion –
- 24.4.1 the vendor must allow or transfer –
- any remaining bond money or any other security against the tenant's default (to the extent the security is transferable);
 - any money in a fund established under the lease for a purpose and compensation for any money in the fund or interest earned by the fund that has been applied for any other purpose; and
 - any money paid by the tenant for a purpose that has not been applied for that purpose and compensation for any of the money that has been applied for any other purpose;
- 24.4.2 if the security is not transferable, each *party* must do whatever is reasonably necessary to cause a replacement security to issue for the benefit of the purchaser and the vendor must hold the original security on trust for the benefit of the purchaser until the replacement security issues;
- 24.4.3 the vendor must give to the purchaser –
- at least 2 *business days* before the date for completion, a proper notice of the transfer (an attornment notice) addressed to the tenant, to be held by the purchaser in escrow until completion;
 - any certificate given under the Retail Leases Act 1994 in relation to the tenancy;
 - a copy of any disclosure statement given under the Retail Leases Act 1994;
 - a copy of any document served on the tenant under the lease and written details of its service, if the document concerns the rights of the landlord or the tenant after completion; and
 - any document served by the tenant under the lease and written details of its service, if the document concerns the rights of the landlord or the tenant after completion;
- 24.4.4 the vendor must comply with any obligation to the tenant under the lease, to the extent it is to be complied with by completion; and
- 24.4.5 the purchaser must comply with any obligation to the tenant under the lease, to the extent that the obligation is disclosed in this contract and is to be complied with after completion.

25 Qualified title, limited title and old system title

- 25.1 This clause applies only if the land (or part of it) –
- 25.1.1 is under qualified, limited or old system title; or
- 25.1.2 on completion is to be under one of those titles.
- 25.2 The vendor must *serve* a proper abstract of title *within 7 days* after the contract date.
- 25.3 If an abstract of title or part of an abstract of title is attached to this contract or has been lent by the vendor to the purchaser before the contract date, the abstract or part is *served* on the contract date.
- 25.4 An abstract of title can be or include a list of documents, events and facts arranged (apart from a will or codicil) in date order, if the list in respect of each document –
- 25.4.1 shows its date, general nature, names of parties and any registration number; and
- 25.4.2 has attached a legible photocopy of it or of an official or registration copy of it.
- 25.5 An abstract of title –
- 25.5.1 must start with a good root of title (if the good root of title must be at least 30 years old, this means 30 years old at the contract date);
- 25.5.2 in the case of a leasehold interest, must include an abstract of the lease and any higher lease;
- 25.5.3 *normally*, need not include a Crown grant; and
- 25.5.4 need not include anything evidenced by the Register kept under the Real Property Act 1900.
- 25.6 In the case of land under old system title –
- 25.6.1 in this contract 'transfer' means conveyance;
- 25.6.2 the purchaser does not have to *serve* the transfer until after the vendor has *served* a proper abstract of title; and
- 25.6.3 each vendor must give proper covenants for title as regards that vendor's interest.
- 25.7 In the case of land under limited title but not under qualified title –
- 25.7.1 *normally*, the abstract of title need not include any document which does not show the location, area or dimensions of the land (for example, by including a metes and bounds description or a plan of the land);
- 25.7.2 clause 25.7.1 does not apply to a document which is the good root of title; and
- 25.7.3 the vendor does not have to provide an abstract if this contract contains a delimitation plan (whether in registrable form or not).
- 25.8 On completion the vendor must give the purchaser any *document of title* that relates only to the *property*.
- 25.9 If on completion the vendor has possession or control of a *document of title* that relates also to other property, the vendor must produce it as and where necessary.
- 25.10 The vendor must give a proper covenant to produce where relevant.
- 25.11 The vendor does not have to produce or covenant to produce a document that is not in the possession of the vendor or a mortgagee.
- 25.12 If the vendor is unable to produce an original document in the chain of title, the purchaser will accept a photocopy from the *Land Registry* of the registration copy of that document.

26 Crown purchase money

- 26.1 This clause applies only if purchase money is payable to the Crown, whether or not due for payment.
 26.2 The vendor is liable for the money, except to the extent this contract says the purchaser is liable for it.
 26.3 To the extent the vendor is liable for it, the vendor is liable for any interest until completion.
 26.4 To the extent the purchaser is liable for it, the *parties* must adjust any interest under clause 14.

27 Consent to transfer

- 27.1 This clause applies only if the land (or part of it) cannot be transferred without consent under *legislation* or a *planning agreement*.
 27.2 The purchaser must properly complete and then *serve* the purchaser's part of an application for consent to transfer of the land (or part of it) *within 7 days* after the contract date.
 27.3 The vendor must apply for consent *within 7 days* after *service* of the purchaser's part.
 27.4 If consent is refused, either *party* can *rescind*.
 27.5 If consent is given subject to one or more conditions that will substantially disadvantage a *party*, then that *party* can *rescind within 7 days* after receipt by or *service* upon the *party* of written notice of the conditions.
 27.6 If consent is not given or refused –
 27.6.1 *within 42 days* after the purchaser *serves* the purchaser's part of the application, the purchaser can *rescind*; or
 27.6.2 *within 30 days* after the application is made, either *party* can *rescind*.
 27.7 Each period in clause 27.6 becomes 90 days if the land (or part of it) is –
 27.7.1 under a *planning agreement*; or
 27.7.2 in the Western Division.
 27.8 If the land (or part of it) is described as a lot in an unregistered plan, each time in clause 27.6 becomes the later of the time and 35 days after creation of a separate folio for the lot.
 27.9 The date for completion becomes the later of the date for completion and 14 days after *service* of the notice granting consent to transfer.

28 Unregistered plan

- 28.1 This clause applies only if some of the land is described as a lot in an unregistered plan.
 28.2 The vendor must do whatever is reasonably necessary to have the plan registered *within 6 months* after the contract date, with or without any minor alteration to the plan or any document to be lodged with the plan validly required or made under *legislation*.
 28.3 If the plan is not registered *within* that time and in that manner –
 28.3.1 the purchaser can *rescind*; and
 28.3.2 the vendor can *rescind*, but only if the vendor has complied with clause 28.2 and with any *legislation* governing the rescission.
 28.4 Either *party* can *serve* notice of the registration of the plan and every relevant lot and plan number.
 28.5 The date for completion becomes the later of the date for completion and 21 days after *service* of the notice.
 28.6 Clauses 28.2 and 28.3 apply to another plan that is to be registered before the plan is registered.

29 Conditional contract

- 29.1 This clause applies only if a provision says this contract or completion is conditional on an event, but does not apply to an event to which clause 28 applies.
 29.2 If the time for the event to happen is not stated, the time is 42 days after the contract date.
 29.3 If this contract says the provision is for the benefit of a *party*, then it benefits only that *party*.
 29.4 If anything is necessary to make the event happen, each *party* must do whatever is reasonably necessary to cause the event to happen.
 29.5 A *party* can *rescind* under this clause only if the *party* has substantially complied with clause 29.4.
 29.6 If the event involves an approval and the approval is given subject to a condition that will substantially disadvantage a *party* who has the benefit of the provision, the *party* can *rescind within 7 days* after either *party* *serves* notice of the condition.
 29.7 If the *parties* can lawfully complete without the event happening –
 29.7.1 if the event does not happen *within* the time for it to happen, a *party* who has the benefit of the provision can *rescind within 7 days* after the end of that time;
 29.7.2 if the event involves an approval and an application for the approval is refused, a *party* who has the benefit of the provision can *rescind within 7 days* after either *party* *serves* notice of the refusal; and
 29.7.3 the date for completion becomes the later of the date for completion and 21 days after the earliest of –
 • either *party* *serving* notice of the event happening;
 • every *party* who has the benefit of the provision *serving* notice waiving the provision; or
 • the end of the time for the event to happen.

- 29.8 If the *parties* cannot lawfully complete without the event happening –
- 29.8.1 if the event does not happen *within* the time for it to happen, either *party* can *rescind*;
- 29.8.2 if the event involves an approval and an application for the approval is refused, either *party* can *rescind*;
- 29.8.3 the date for completion becomes the later of the date for completion and 21 days after either *party* serves notice of the event happening.
- 29.9 A *party* cannot *rescind* under clauses 29.7 or 29.8 after the event happens.

30 Manual transaction

- 30.1 This clause applies if this transaction is to be conducted as a *manual transaction*.
- **Transfer**
- 30.2 *Normally*, the purchaser must *serve* the transfer at least 7 days before the date for completion.
- 30.3 If any information needed for the transfer is not disclosed in this contract, the vendor must *serve* it.
- 30.4 If the purchaser *serves* a transfer and the transferee is not the purchaser, the purchaser must give the vendor a direction signed by the purchaser personally for that transfer.
- 30.5 The vendor can require the purchaser to include a covenant or easement in the transfer only if this contract contains the wording of the proposed covenant or easement, and a description of the land burdened and benefited.
- **Place for completion**
- 30.6 *Normally*, the *parties* must complete at the completion address, which is –
- 30.6.1 if a special completion address is stated in this contract - that address; or
- 30.6.2 if none is stated, but a first mortgagee is disclosed in this contract and the mortgagee would usually discharge the mortgage at a particular place - that place; or
- 30.6.3 in any other case - the vendor's *solicitor's* address stated in this contract.
- 30.7 The vendor by reasonable notice can require completion at another place, if it is in NSW, but the vendor must pay the purchaser's additional expenses, including any agency or mortgagee fee.
- 30.8 If the purchaser requests completion at a place that is not the completion address, and the vendor agrees, the purchaser must pay the vendor's additional expenses, including any agency or mortgagee fee.
- **Payments on completion**
- 30.9 On completion the purchaser must pay to the vendor the amounts referred to in clauses 16.5.1 and 16.5.2, by cash (up to \$2,000) or *settlement cheque*.
- 30.10 *Normally*, the vendor can direct the purchaser to produce a *settlement cheque* on completion to pay an amount adjustable under this contract and if so –
- 30.10.1 the amount is to be treated as if it were paid; and
- 30.10.2 the *cheque* must be forwarded to the payee immediately after completion (by the purchaser if the *cheque* relates only to the *property* or by the vendor in any other case).
- 30.11 If the vendor requires more than 5 *settlement cheques*, the vendor must pay \$10 for each extra *cheque*.
- 30.12 If the purchaser must make a *GSTRW payment* the purchaser must –
- 30.12.1 produce on completion a *settlement cheque* for the *GSTRW payment* payable to the Deputy Commissioner of Taxation;
- 30.12.2 forward the *settlement cheque* to the payee immediately after completion; and
- 30.12.3 *serve* evidence of receipt of payment of the *GSTRW payment* and a copy of the settlement date confirmation form submitted to the Australian Taxation Office.
- 30.13 If the purchaser must pay an *FRCGW remittance*, the purchaser must –
- 30.13.1 produce on completion a *settlement cheque* for the *FRCGW remittance* payable to the Deputy Commissioner of Taxation;
- 30.13.2 forward the *settlement cheque* to the payee immediately after completion; and
- 30.13.3 *serve* evidence of receipt of payment of the *FRCGW remittance*.

31 Foreign Resident Capital Gains Withholding

- 31.1 This clause applies only if –
- 31.1.1 the sale is not an excluded transaction within the meaning of s14-215 of Schedule 1 to the *TA Act*; and
- 31.1.2 a *clearance certificate* in respect of every vendor is not attached to this contract.
- 31.2 If the vendor *serves* any *clearance certificate* or *variation*, the purchaser does not have to complete earlier than 5 *business days* after that *service* and clause 21.3 does not apply to this provision.
- 31.3 The purchaser must at least 2 *business days* before the date for completion, *serve* evidence of submission of a purchaser payment notification to the Australian Taxation Office by the purchaser or, if a direction under either clause 4.8 or clause 30.4 has been given, by the transferee named in the transfer the subject of that direction.
- 31.4 The vendor cannot refuse to complete if the purchaser complies with clause 31.3 and, as applicable, clauses 4.10 or 30.13.
- 31.5 If the vendor *serves* in respect of every vendor either a *clearance certificate* or a *variation* to 0.00 percent, clauses 31.3 and 31.4 do not apply.

32 Residential off the plan contract

- 32.1 This clause applies if this contract is an off the plan contract within the meaning of Division 10 of Part 4 of the Conveyancing Act 1919 (the Division).
- 32.2 No provision of this contract has the effect of excluding, modifying or restricting the operation of the Division.
- 32.3 If the purchaser makes a claim for compensation under the terms prescribed by sections 4 to 6 of Schedule 3 to the Conveyancing (Sale of Land) Regulation 2022 –
- 32.3.1 the purchaser cannot make a claim under this contract about the same subject matter, including a claim under clauses 6 or 7; and
 - 32.3.2 the claim for compensation is not a claim under this contract.

UNIT 2, 30 THIRD AVE EPPING NSW 2127

SECTION 66W CERTIFICATE

VENDORS: ("the Vendors")
PURCHASERS: ("the Purchasers")
PROPERTY: ("the Property")

I,
Solicitor/Barrister/Licensed Conveyancer certify as follows:

- (a) I am a Solicitor/Barrister/Licensed Conveyancer currently admitted to practice in New South Wales.
- (b) I am giving this certificate in accordance with Section 66W of the Conveyancing Act, 1919 with reference to a contract for the sale of the Property from the Vendor to the Purchaser in order that there is no cooling off period in relation to that contract.
- (c) I do not act for the Vendor and am not employed in the legal practice of a Solicitor/Barrister/Licensed Conveyancer acting for the Vendor now am I a member or employee of a firm of which a Solicitor/Barrister/Licensed Conveyancer acting for the Vendor is a member or employee.
- (d) I have explained to the Purchaser:
 - (i) the effect of the contract for the purchase of the Property
 - (ii) the nature of this certificate
 - (iii) the effect of giving this certificate to the Vendor ie. that there is no cooling off period in relation to the contract

Date:

.....

Signature

ADDITIONAL CONDITIONS IN CONTRACT FOR SALE OF LAND

The terms of the printed Contract to which these additional conditions are annexed shall be read subject to the following. If there is a conflict between these additional conditions and the printed Contract, then these additional conditions shall prevail. The parties agree that should any provision be held to be contrary to law, void or unenforceable, then such provision shall be severed from this Contract and such remaining provisions shall remain in full force and effect.

33. Amendments to Printed Form

The form of contract annexed is amended as follows:

- (a) In Definitions any reference to a building society, credit union or other FCA institution as a settlement cheque is deleted;
- (b) Notwithstanding anything to the contrary herein contained the parties expressly agree that any claim for compensation whether under Clause 6 and 7 otherwise shall be deemed to be an objection or requisition for the purposes of Clause 8 hereof;
- (c) Delete Clause 7.1.1, amend 7.1.3 by deleting "within 14 days" and substituting with "within 7 days" and amending 7.2.1 by deleting the figure 10% and substituting with \$1.00;
- (d) Delete Clause 14.4.2;
- (e) Printed Clause 18 is amended by adding the following:
Clause 18.8 "The Purchaser cannot make a claim or requisition or delay settlement after entering into possession of the property".
- (f) Delete Clause 23.6 and 23.7;
- (g) Clause 23.13 delete and replace with the words "The vendor hereby authorizes the purchaser to obtain a certificate under s184 of the Strata Scheme Management Act 2015 and/or under s171 of the Community Land Management Act 2021"
- (h) Clause 23.14 is amended by deleting the words "The purchaser does not have to complete earlier than 7 days after service of the certificate and clause 21.3 does not apply to this provision.";
- (i) Delete Clause 23.15;
- (j) Delete Clause 25;
- (k) Clause 31.2 of the Contract is hereby amended to now read "2" days in lieu of "5" days.

34. Capacity

If the Vendor or Purchaser or if more than one of them shall die, become mentally ill or go into bankruptcy, then either party may rescind the Contract and Clause 19 of the Contract shall apply.

35. Representations, Warranties and Acknowledgements

- (a) The Purchaser acknowledges that no representations, inducements or warranties have been made by the Vendor or its agents or representatives relating to the present state or condition or relating to any proposed work or improvements to the property or any part thereof and the Purchaser purchases the property in its existing condition and state of repair.
- (b) The Purchaser acknowledges that the provisions of this Contract constitute the full and complete understanding between the parties and that there is no other understanding, agreement, warranty or representation whether expressed or implied in any way extending, defining or otherwise relating to the provisions of this Contract of binding on the parties hereto with respect to any of the matter to which this Contract relates.
- (c) The Purchaser warrants that he has not been introduced to the property other than by the Vendor's agents specified in this Contract. The Purchaser will indemnify the Vendor against any claim or demand for commission or remuneration by any person other than the Vendor's agent arising from the sale of the property and pursuant to a breach of the Purchaser's warranty provided by this special condition. This special condition will not merge upon completion.
- (d) The Purchaser has relied entirely upon the Purchaser's own enquiries and inspection of the property.
- (e) The Purchaser is satisfied in all respects as to the nature, quality, condition and state of repair of the property (including any holes which are a result of the removal of any pictures, surround sound systems, TV brackets or any other wires relating thereto) including the purposes for which the property may be lawfully used.
- (f) The Purchaser acknowledges and agrees that the property is sold and accepted by the Purchaser subject to all or any encroachments by and upon the property and non-compliance by the improvement thereon with the requirements of the Local Government Act 1993 or any regulation thereunder and to all defects (whether latent or patent) in its present state of repair, condition, dilapidation and infestation.
- (g) The Purchaser is not entitled to rescind, terminate or delay completion of this Contract, nor to object, requisition or make any claim (whether for compensation or not) in respect of any defects (whether latent or patent) in the nature, quality, condition, state of repair of the property or any other matter, fact or thing referred to in this Clause 35.
- (h) The Purchaser shall not call upon the Vendor to carry out any repairs whatsoever in relation to the property.
- (i) The Purchaser accepts the property subject to all existing water, sewage, drainage and plumbing connections to the dwelling in respect of the property and the presence, nature, location, availability or non-availability of any services as defined in Clause 10.1.2.

36. Deposit

Notwithstanding anything else herein contained, the deposit or any part of the deposit as the Vendor may require shall be released to the Vendor or as the Vendor may direct for the sole purpose of:

- (a) For the payment of a deposit and/or stamp duty on any piece of real estate that the Vendors negotiate to purchase between the date hereof and the date of settlement hereof;
- (b) For the payment of land tax;
- (c) For the payment of a rental bond; or
- (d) For the payment of a licence fee, deed of loan, entry contribution or lease payment on an over 55's or retirement unit.
- (e) For the funds to be available in the Pexa workspace for settlement

37. Deposit Payment and Cooling Off Period

The Vendor(s) and the Purchaser(s) agree that for the purposes of Clause 2.3, the deposit must be paid to the deposit holder as follows:

- (i) \$ _____ on the date of this Contract.
- (ii) \$ _____ on or before the expiration of the Cooling off Period provided for in this Contract.

The Vendor(s) and the Purchaser(s) agree that the Cooling off Period shall be extended until 5.00pm on the () business day after the date of this Contract.

The Vendor(s) and the Purchaser(s) hereby agree to exchange by way of:

- (i) Ten (10%) Percent Deposit Guarantee Bond
- (ii) Five (5%) Percent Deposit
- (iii) Ten (10%) Percent Deposit

38. Extension of cooling off period

In the event that it is agreed that there shall be an extension of the cooling off period under this Contract, it is hereby agreed that the Solicitor or Licensed Conveyancer for the Vendors shall be entitled to grant the extension in writing on behalf of the vendor pursuant to Section 66S (4) of the Conveyancing Act.

39. Deposit Power Guarantee

The Parties agree that:

- (a) The Purchaser has, at exchange, provided the Vendor with a Deposit Power Guarantee ("Guarantee") in the amount of _____ which is dated _____ ; and
- (b) The Guarantee will be dealt with as if it were a cash deposit under the Contract, and the Vendor is entitled to immediately draw upon the Guarantee in any circumstances where the Vendor is entitled to the Deposit; and
- (c) At settlement the Purchaser must pay to the Vendor in addition to all other moneys payable under this Contract, the full purchase price (less any deposit held by the agent) and the Vendor will return the original Guarantee to the Purchaser.

40. Completion

- (a) Completion of this Contract will take place on the Completion Date.
- (b) In the event that:
 - (i) The purchaser defaults in the observance of any obligation hereunder which is or the performance of which has become essential; and
 - (ii) The purchaser has paid a deposit of less than ten (10%) of the purchase price; and
 - (iii) The vendor terminates this Contract or the Purchaser does not rescind this Contract in accordance with the "cooling off" provisions created by Section 66S of the Conveyancing Act,

then the vendor shall be entitled to recover from the Purchaser, an amount equal to ten per centum (10%) of the purchase price less any deposit paid, as liquidated damages and it is agreed that this right shall be in addition to and shall not limit any remedies available to the Vendor herein contained or implied notwithstanding any rule of Law or equity to the contrary. This special condition shall not merge upon completion of this contract.

- (c) If the Purchaser shall not complete this purchase by the agreed completion date, at a time when the Vendor is ready, willing and able to complete on or after that completion date, then the Purchaser shall pay to the Vendor on completion, in addition to the balance of purchase money, an amount calculated as seven percent (7%) interest on the balance of purchase money, computed at a daily rate from the day immediately after the agreed completion date up to and including the actual date on which this sale shall be completed. It is further agreed that this amount is a genuine pre-estimate of the Vendor's loss of interest for the purchase money and liability for rates and outgoings. The Vendor shall not be obliged to complete this Contract unless the amount payable under this clause is tendered.
- (d) Settlement of this matter is to take place electronically online through Property Exchange Australia Ltd (PEXA). Should the Purchaser serve a notice under printed condition 30 to conduct a manual transaction then the Purchaser must pay to the Vendor on settlement the amount of \$150 (inclusive of GST), being an additional legal cost incurred by the Vendor as a consequence of the Purchaser not settling the matter electronically, which sum is to be allowed by the Purchaser in favour of the Vendor as an additional adjustment on completion.
- (e) If the property is not mortgaged and settlement cannot, for whatever reason, take place on the PEXA platform, then settlement will take place at the office of Hills Conveyancing. However, should the Purchaser not be in a position to settle at the office of Hills Conveyancing, then settlement may be effected in the Sydney CBD at a place nominated by the Purchaser, so long as the Vendor's Licensed Conveyancers' Settlement Agent's fee is paid by the Purchaser.
- (f) Should completion not take place on the Completion Date then either party shall be at liberty to issue a Notice to Complete ("Notice") calling for the other party to complete the matter making the time for completion essential. Such Notice shall give not less than 14 days' notice after the day immediately following the day on which that notice is received by the recipient of the notice. A Notice to Complete of such duration is considered by the parties as being deemed reasonable and sufficient to render the time for completion essential. The party that issues the Notice to Complete shall also be at liberty to withdraw such Notice to Complete and re-issue another one at any time. If the Vendor issues a Notice to Complete against the Purchaser, then the Vendor shall be entitled to recover the fee of \$330.00 (GST inclusive) from the Purchaser to cover the cost for issuing such Notice.
- (g) The service of any Notice or Document under or relating to this Contract may, in addition to the provisions of Clause 20, be effected and shall be sufficient service on a party and that party's Solicitor/Licensed Conveyancer if the Notice or Document is sent by email noted on the Contract or on their letterhead and in any such case shall be deemed to be duly given or made, except where the time of dispatch is not before 5.00pm (Sydney time) on a day which business is generally carried on in the place to which such notice is sent, in which case the Notice shall be deemed to have been received at the commencement of business on the next such business day in the place.

41. Requisitions on Title

The parties agree that the only form of general requisitions on title that the Purchaser shall be entitled to raise pursuant to Clause 5 of this Contract shall be in the form of Requisitions on Title annexed to this Contract.

42. Survey

If a Survey of the property is annexed to this Contract, the Purchaser acknowledges having inspected the Survey and agreed that no objection requisition or claim for compensation shall be made on any matter referred to in the Survey.

43. Building Certificate

- (a) The vendor does not have a Building Certificate.

- (b) Completion of this Contract is not conditional on the vendor or the purchaser obtaining a Building Certificate.
- (c) If the purchaser applies for a Building Certificate from the local Council and a Notice issues requiring work to be done to the property or informs the purchaser of work to be done before it will issue the Certificate, the purchaser shall not be entitled to make any objection, requisition or claim for compensation under any provision of this Contract and the vendor shall be under no obligation to carry out any works or comply with any notice aforesaid and the purchaser will complete this Contract notwithstanding the same.

44. Licence

Should the Vendor agree to allow the Purchaser to move in under licence an agreed fee of \$ _____ per week or part thereof is to be adjusted on settlement and paid to the Vendor on completion with the balance of the purchase price and:

- (a) That if settlement is not affected on the due date, by no fault of the Vendor, then the fee will increase from the due date for completion to \$ _____ per week or part thereof up until and including the date that settlement takes place; and
- (b) That if the property is a house, then the Purchaser will have a current House Insurance policy in place, and the Purchaser will provide a copy of the policy to the Vendor's Licensed Conveyancer prior to obtaining the keys to the property; and
- (c) That the Purchaser accepts the property in its present state and condition in accordance with clause 18 of the Contract for Sale; and
- (d) That the Purchaser accepts all responsibility for the property and its improvements and inclusions from the date that they move into the property and will not delay completion, make any requisitions, objections or claim for compensation from the Vendor in relation thereto.

45. Christmas Closure Period

- (a) If the completion of the cooling off period falls between 23 December 2026 and 11 January 2027 then both parties hereby agree the cooling off period will be extended to expire at 5.00pm on 12 January 2027.
- (b) If the completion of the Contract for Sale ("the settlement date") falls between 23 December 2026 and 11 January 2027, both parties hereby agree the settlement date will be 15 January 2027.
- (c) Notwithstanding any other term or condition in this contract if either party serves another party with a Notice to Complete between 23 December 2026 and 11 January 2027 then both parties hereby agree that the notice is deemed to require completion by 15 January 2027.

46. Section 184 Certificate or Section 171 Certificate

This clause applies only if the land (or part of it) as a Lot in a Strata, Neighbourhood or Community scheme (or on completion is to be a Lot in a Scheme of that kind).

The Purchaser shall be responsible for applying to the holder of the Strata or Community Title for records of s.184 Certificate under the Strata Schemes Management Act 2015 or for s.171 Certificate under the Community Land Management Act 2021. The Purchaser shall not be entitled to delay completion or make any requisition or objection arising from the purchaser's failure to apply for the said Certificate.

The Vendor hereby authorizes the Purchaser to apply for s184 Certificate under the Strata Scheme Management Act 2015 or for s171 Certificate under the Community Land Management Act 2021. The Purchaser shall provide to the Vendor with the said Certificate five (5) Business days prior to completion.

47. Sewer and Drainage Services

If no sewer connections diagram is attached to this contract showing improvements are connected to the sewer main, then none was available to order from the relevant authority and the purchaser shall not be entitled to make any requisitions, rescind or terminate the contract or make a claim on the vendor in this regard.

48. Settlement cancellation

In the event that this Contract is not completed by the time stipulated on the Contract, by way of default by the Purchaser, then the Purchaser shall pay the Vendor's Solicitors costs of \$330.00 to reschedule the settlement. The sum is to be adjusted on completion.

49. Settlement figures

The Purchaser must serve draft settlement figures, along with all applicable certificates upon the Vendor, no less than 3 days prior to the completion date, should the Purchaser fail to serve the abovementioned documents within the prescribed time, then it is an essential term of this Contract that the Purchaser shall pay the Vendor's conveyancers costs of \$150.00 (inclusive of GST) on completion, being additional costs incurred and arising from the delay in service of the abovementioned documents.

50. Conditions of Sale of Land by Auction

These conditions replace 'Auction - Conditions of Sale' on page 3 of the printed contract.

If the property is or is intended to be sold at auction:

Bidders Record means the Bidders Record to be kept pursuant to Clause 18 of the *Property, Stock and Business Agents Regulation 2003* and Section 68 of the *Property, Stock and Business Agents Act 2002*:

1. The following conditions are prescribed as applicable to and in respect of the sale by auction of land:
 - (a) The principal's reserve price must be given in writing to the auctioneer before the auction commences.
 - (b) A bid for the seller cannot be made unless the auctioneer has, before the commencement of the auction, announced clearly and precisely the number of bids that may be made by or on behalf of the seller.
 - (c) The highest bidder is the purchaser, subject to any reserve price.
 - (d) In the event of a disputed bid, the auctioneer is the sole arbitrator and the auctioneer's decision is final.
 - (e) The auctioneer may refuse to accept any bid that, in the auctioneer's opinion, is not in the best interests of the seller.
 - (f) A bidder is taken to be a principal unless, before bidding, the bidder has given to the auctioneer a copy of the written authority to bid for or on behalf of another person.
 - (g) A bid cannot be made or accepted after the fall of the hammer.
 - (h) As soon as practicable after the fall of the hammer the purchaser is to sign the agreement (if any) for sale.
2. The following conditions, in addition to those prescribed by subclause (1), are prescribed as applicable to and in respect of the sale by auction of residential property or rural land:
 - (a) All bidders must be registered in the Bidders Record and display an identifying number when making a bid.
 - (b) One bid only may be made by or on behalf of the seller. This includes a bid made by the auctioneer on behalf of the seller.
 - (c) When making a bid on behalf of the seller or accepting a bid made by or on behalf of the seller, the auctioneer must clearly state that the bid was made by or on behalf of the seller or auctioneer.

STRATA TITLE (RESIDENTIAL) PROPERTY REQUISITIONS ON TITLE

Vendor:
Purchaser:
Property:
Dated:

Possession and tenancies

1. Vacant possession of the Property must be given on completion unless the Contract provides otherwise.
2. Is anyone in adverse possession of the Property or any part of it?
3.
 - (a) What are the nature and provisions of any tenancy or occupancy?
 - (b) If they are in writing, all relevant documentation should be produced, found in order and handed over on completion with notices of attornment.
 - (c) Please specify any existing breaches.
 - (d) All rent should be paid up to or beyond the date of completion.
 - (e) Please provide details of any bond together with the Rental Bond Board's reference number.
 - (f) If any bond money is held by the Rental Bond Board, the appropriate transfer documentation duly signed should be handed over on completion.
4. Is the Property affected by a protected tenancy (tenancy affected by Parts 2, 3, 4 or 5 of the *Landlord and Tenant (Amendment) Act 1948 (NSW)*)? If so, please provide details.
5. If the tenancy is subject to the *Residential Tenancies Act 2010 (NSW)*:
 - (a) has either the vendor or any predecessor or the tenant applied to the NSW Civil and Administrative Tribunal for an order?
 - (b) have any orders been made by the NSW Civil and Administrative Tribunal? If so, please provide details.

Title

6. Subject to the Contract, on completion the vendor should be registered as proprietor in fee simple of the Property free from all encumbrances and notations and recorded as the owner of the Property on the strata roll, free from all other interests.
7. On or before completion, any mortgage, caveat, writ or priority notice must be discharged, withdrawn, cancelled or removed as the case may be or, in the case of a mortgage, caveat or priority notice, an executed discharge or withdrawal or removal handed over on completion together with a notice under Section 22 of the *Strata Schemes Management Act 2015 (NSW) (Act)*.
8. Are there any proceedings pending or concluded that could result in the recording of any writ on the title to the Property or in the General Register of Deeds? If so, full details should be provided at least 14 days prior to completion.
9. When and where may the title documents be inspected?
10. Are any chattels or fixtures subject to any hiring or leasing agreement or charge or to any security interest under the *Personal Properties Securities Act 2009 (Cth)*? If so, details must be given and all indebtedness cleared and title transferred unencumbered to the vendor prior to completion.

Adjustments

11. All outgoings referred to in clause 14.1 of the Contract must be paid up to and including the date of completion.
12. Is the vendor liable to pay land tax or is the Property otherwise charged or liable to be charged with land tax? If so:
 - (a) to what year has a return been made?
 - (b) what is the taxable value of the Property for land tax purposes for the current year?
13. The vendor must serve on the purchaser a current land tax certificate (issued under Section 47 of the *Land Tax Management Act 1956 (NSW)*) at least 14 days before completion.

Survey and building

14. Subject to the Contract, survey should be satisfactory and show that the whole of the Property and the common property is available, that there are no encroachments by or upon the Property or the common property.
15. Is the vendor in possession of a survey report? If so, please produce a copy for inspection prior to completion. The original should be handed over on completion.
16. In respect of the Property and the common property:
 - (a) Have the provisions of the *Local Government Act (NSW)*, the *Environmental Planning and Assessment Act 1979 (NSW)* and their regulations been complied with?
 - (b) Is there any matter that could justify the making of an upgrading or demolition order in respect of any building or structure?
 - (c) Has the vendor a Building Certificate which relates to all current buildings or structures on the Property? If so, it should be handed over on completion. Please provide a copy in advance.

- (d) Has the vendor a Final Occupation Certificate issued under the *Environmental Planning and Assessment Act 1979* for all current buildings or structures on the Property? If so, it should be handed over on completion. Please provide a copy in advance.
 - (e) In respect of any residential building work carried out in the last 7 years:
 - (i) please identify the building work carried out;
 - (ii) when was the building work completed?
 - (iii) please state the builder's name and licence number;
 - (iv) please provide details of insurance under the *Home Building Act 1989 (NSW)*.
 - (f) Are there any proposals by the Owners Corporation or an owner of a lot to make any additions or alterations or to erect any new structures on the common property? If so, please provide details.
 - (g) Has any work been carried out by the vendor on the Property or the common property? If so:
 - (i) has the work been carried out in accordance with the by-laws and all necessary approvals and consents?
 - (ii) does the vendor have any continuing obligations in relation to the common property affected?
17. Is the vendor aware of any proposals to:
- (a) resume the whole or any part of the Property or the common property?
 - (b) carry out building alterations to an adjoining lot which may affect the boundary of that lot or the Property?
 - (c) deal with, acquire, transfer, lease or dedicate any of the common property?
 - (d) dispose of or otherwise deal with any lot vested in the Owners Corporation?
 - (e) create, vary or extinguish any easements, restrictions or positive covenants over the Property or the common property?
 - (f) subdivide or consolidate any lots and/or any common property or to convert any lots into common property?
 - (g) grant any licence to any person, entity or authority (including the Council) to use the whole or any part of the common property?
18. Has the vendor (or any predecessor) or the Owners Corporation entered into any agreement with or granted any indemnity to the Council or any other authority concerning any development on the Property or the common property?
19. In relation to any swimming pool on the Property or the common property:
- (a) did its installation or construction commence before or after 1 August 1990?
 - (b) has the swimming pool been installed or constructed in accordance with approvals under the *Local Government Act 1919 (NSW)* and *Local Government Act 1993 (NSW)*?
 - (c) does it comply with the provisions of the *Swimming Pools Act 1992 (NSW)* and regulations relating to access? If not, please provide details of the exemptions claimed;
 - (d) have any notices or orders issued or been threatened under the *Swimming Pools Act 1992 (NSW)* or regulations?
 - (e) if a certificate of non-compliance has issued, please provide reasons for its issue if not disclosed in the contract;
 - (f) originals of certificate of compliance or non-compliance and occupation certificate should be handed over on settlement.
- 20.
- (a) Is the vendor aware of any dispute regarding boundary or dividing fences in the strata scheme?
 - (b) Is the vendor aware of any notice, claim or proceedings under the *Dividing Fences Act 1991 (NSW)* or the *Encroachment of Buildings Act 1922 (NSW)* affecting the strata scheme?

Affectations, notices and claims

21. In respect of the Property and the common property:
- (a) Is the vendor aware of any rights, licences, easements, covenants or restrictions as to use of them other than those disclosed in the Contract?
 - (b) Has any claim been made by any person to close, obstruct or limit access to or from them or to prevent the enjoyment of any easement appurtenant to them?
 - (c) Is the vendor aware of:
 - (i) any road, drain, sewer or storm water channel which intersects or runs through them?
 - (ii) any dedication to or use by the public of any right of way or other easement over any part of them?
 - (iii) any latent defects in them?
 - (d) Has the vendor any notice or knowledge of them being affected by the following:
 - (i) any notice requiring work to be done or money to be spent on them or any footpath or road adjoining? If so, such notice must be complied with prior to completion.
 - (ii) any work done or intended to be done on them or the adjacent street which may create a charge on them or the cost of which might be or become recoverable from the purchaser?
 - (iii) any sum due to any local or public authority recoverable from the purchaser? If so, it must be paid prior to completion.
 - (iv) any realignment or proposed realignment of any road adjoining them?
 - (v) any contamination including, but not limited to, materials or substances dangerous to health such as asbestos and fibreglass?

Applications, Orders etc

22. Are there any applications made, proposed or threatened, whether by an owner of a lot or the Owners Corporation, to the NSW Civil and Administrative Tribunal, any Court or to the Registrar General for orders relating to the strata scheme, the Property or the common property (including orders to vary the strata scheme consequent upon damage or destruction or to terminate the strata scheme) which are yet to be determined? If so, please provide particulars.
23. Are there any mediations currently being conducted by the Commissioner of Fair Trading, Department of Finance Services and Innovation in relation to the Property or the common property which involve the vendor or the Owners Corporation? If so, please provide particulars.
24. Are there any:
- (a) orders of the Tribunal;
 - (b) notices of or investigations by the Owners Corporation;
 - (c) notices or orders issued by any Court; or
 - (d) notices or orders issued by the Council or any public authority or water authority, affecting the Property or the common property not yet complied with? In so far as they impose an obligation on the vendor they should be complied with by the vendor before completion.
25. Have any orders been made by any Court or Tribunal that money (including costs) payable by the Owners Corporation be paid from contributions levied in relation to the Property? If so, please provide particulars.
26. Has the vendor made any complaints or been the subject of any complaints arising out of noise affecting the Property or emanating from the Property?
27. Has any proposal been given by any person or entity to the Owners Corporation for:
- (a) a collective sale of the strata scheme; or
 - (b) a redevelopment of the strata scheme?
- If so, please provide particulars of the proposal and the steps taken and decisions made in relation to the proposal to the present time.

Owners Corporation management

28. Has the initial period expired?
29. Are any actions proposed to be taken or have any been taken by the Owners Corporation in the initial period which would be in breach of its powers without an order authorising them?
30. If the Property includes a utility lot, please specify the restrictions.
31. Do any special expenses (as defined in clause 23.2 of the Contract, including any liabilities of the Owners Corporation) exceed 1% of the price?
32. Has an appointment of a strata managing agent and/or a building manager been made? If so:
- (a) who has been appointed to each role;
 - (b) when does the term of each appointment expire; and
 - (c) what functions have been delegated to the strata managing agent and/or the building manager.
33. Has the Owners Corporation entered into any agreement to provide amenities or services to the Property? If so, please provide particulars.
34. Has a resolution been passed for the distribution of surplus money from the administrative fund or the capital works fund? If so, please provide particulars.
35. Have the by-laws adopted a common property memorandum as prescribed by the regulations for the purposes of Section 107 of the Act? If so, has the memorandum been modified? Please provide particulars.
36. Is there a registered building management statement pursuant to Section 108 of the *Strata Schemes Development Act 2015 (NSW)*? If so, are there any proposals to amend the registered building management statement?
37. If the strata scheme was in existence at 30 November 2016, has the Owners Corporation taken steps to review the by-laws that were current at that date? If so, please provide particulars.
38. Are there any pending proposals to amend or repeal the current by-laws or to add to them?
39. Are there any proposals, policies or by-laws in relation to the conferral of common property rights or which deal with short term licences and/or holiday lettings?
40. If not attached to the Contract, a strata information certificate under Section 184 of the Act should be served on the purchaser at least 7 days prior to completion.
41. Has the Owners Corporation met all of its obligations under the Act relating to:
- (a) insurances;
 - (b) fire safety;
 - (c) occupational health and safety;
 - (d) building defects and rectification in relation to any applicable warranties under the *Home Building Act 1989 (NSW)*;
 - (e) the preparation and review of the 10 year plan for the capital works fund; and
 - (f) repair and maintenance.
42. Is the secretary of the Owners Corporation in receipt of a building bond for any building work on a building that is part of the Property or the common property?
43. Has an internal dispute resolution process been established? If so, what are its terms?
44. Has the Owners Corporation complied with its obligation to lodge tax returns with the Australian Taxation Office and has all tax liability been paid?

Capacity

45. If the Contract discloses that the vendor is a trustee, evidence should be produced to establish the trustee's power of sale.

Requisitions and transfer

46. If not attached to the Contract and the transaction is not an excluded transaction, any *clearance certificate* under Section 14-220 of Schedule 1 of the *Taxation Administration Act 1953 (Cth)* should be served on the purchaser at least 7 days prior to completion.
47. If the transfer or any other document to be handed over on completion is executed pursuant to a power of attorney, then at least 7 days prior to completion a copy of the registered power of attorney should be produced and found in order.
48. If the vendor has or is entitled to have possession of the title deeds the Certificate Authentication Code must be provided 7 days prior to settlement.
49. Searches, surveys, enquiries and inspection of title deeds must prove satisfactory.
50. The purchaser reserves the right to make further requisitions prior to completion.
51. Unless we are advised by you to the contrary prior to completion, it will be assumed that your replies to these requisitions remain unchanged as at the completion date.



Title Search

Information
Provided
Through
triSearch
(Website)
Ph. 1300 064
452

NEW SOUTH WALES LAND REGISTRY SERVICES - TITLE SEARCH

FOLIO: 2/SP65573

SEARCH DATE	TIME	EDITION NO	DATE
-----	----	-----	----
20/3/2026	11:31 AM	5	8/9/2018

LAND

LOT 2 IN STRATA PLAN 65573
AT EPPING
LOCAL GOVERNMENT AREA CITY OF PARRAMATTA

FIRST SCHEDULE

SUSAN STRICKLAND CAPP (T AA898331)

SECOND SCHEDULE (2 NOTIFICATIONS)

- 1 INTERESTS RECORDED ON REGISTER FOLIO CP/SP65573
- 2 AH906889 MORTGAGE TO WESTPAC BANKING CORPORATION

NOTATIONS

UNREGISTERED DEALINGS: NIL

*** END OF SEARCH ***



Title Search

Information
Provided
Through
triSearch
(Website)
Ph. 1300 064
452

NEW SOUTH WALES LAND REGISTRY SERVICES - TITLE SEARCH

FOLIO: CP/SP65573

SEARCH DATE	TIME	EDITION NO	DATE
20/3/2026	11:31 AM	6	22/11/2024

LAND

THE COMMON PROPERTY IN THE STRATA SCHEME BASED ON STRATA PLAN 65573
WITHIN THE PARCEL SHOWN IN THE TITLE DIAGRAM

AT EPPING
LOCAL GOVERNMENT AREA CITY OF PARRAMATTA
PARISH OF FIELD OF MARS COUNTY OF CUMBERLAND
TITLE DIAGRAM SP65573

FIRST SCHEDULE

THE OWNERS - STRATA PLAN NO. 65573
ADDRESS FOR SERVICE OF DOCUMENTS:
BCMS PTY LTD
LOCKED BAG 22
HAYMARKET 1238

SECOND SCHEDULE (7 NOTIFICATIONS)

- 1 RESERVATIONS AND CONDITIONS IN THE CROWN GRANT(S)
- 2 DP776680 EASEMENT FOR SEWERAGE PURPOSES OVER EXISTING LINE OF PIPES APPURTENANT TO THE PART(S) OF THE LAND SHOWN SO BENEFITED IN THE TITLE DIAGRAM
- 3 DP776680 EASEMENT TO DRAIN WATER 1.25 METRE(S) WIDE APPURTENANT TO THE PART(S) OF THE LAND SHOWN SO BENEFITED IN THE TITLE DIAGRAM
- 4 SP65573 POSITIVE COVENANT
- 5 SP65573 RESTRICTION(S) ON THE USE OF LAND
- 6 AT697022 INITIAL PERIOD EXPIRED
- 7 AU598430 CONSOLIDATION OF REGISTERED BY-LAWS

SCHEDULE OF UNIT ENTITLEMENT (AGGREGATE: 100)

STRATA PLAN 65573

LOT	ENT	LOT	ENT	LOT	ENT	LOT	ENT
1	- 15	2	- 15	3	- 15	4	- 13
5	- 14	6	- 14	7	- 14		

NOTATIONS

UNREGISTERED DEALINGS: NIL

*** END OF SEARCH ***

GARAGE LEVEL

SP65573

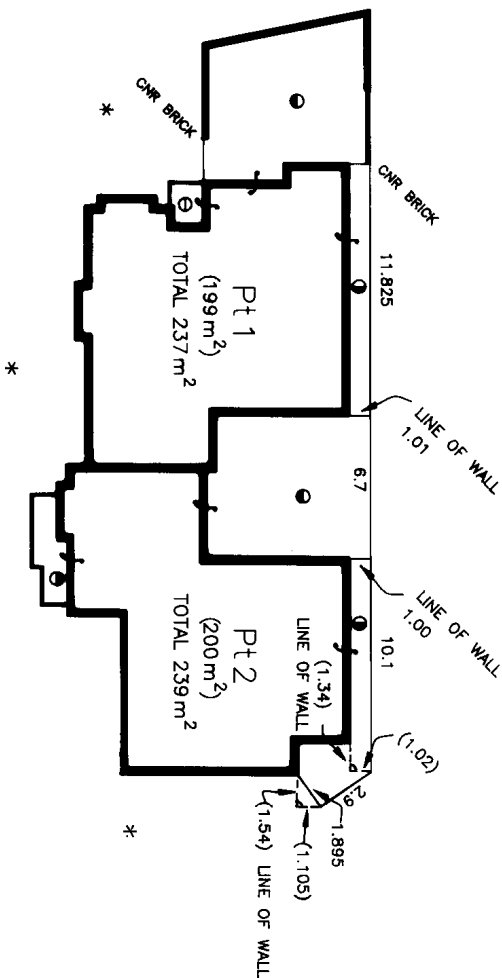
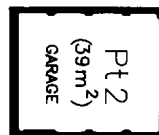
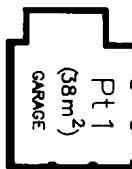

*OFFICE USE ONLY

- AREAS ARE APPROXIMATE ONLY AND INCLUDE COURTYARDS, GARDEN AREAS AND PORCHES WHERE SHOWN
- ⊖ DENOTES COVERED PORCH
- DENOTES COURTYARD LIMITED IN HEIGHT FROM 2 BELOW TO 3 ABOVE THE UPPER SURFACE OF THE MAIN FLOOR OF THE ADJACENT PART LOT EXCEPT WHERE PAVED OR COVERED
- DENOTES GARDEN AREA LIMITED IN HEIGHT FROM 3 BELOW TO 3 ABOVE THE UPPER SURFACE OF THE MAIN FLOOR OF THE ADJACENT PART LOT EXCEPT WHERE PAVED OR COVERED
- DENOTES PORCH & STAIRS LIMITED IN HEIGHT TO 2.4 ABOVE THE CONCRETE FLOOR THEREOF EXCEPT WHERE COVERED
- ∟ DENOTES RIGHT ANGLE
- └ DENOTES CORNER OF WALL
- * DENOTES COMMON PROPERTY

Reduction Ratio 1: 250

Lengths are in metres

Surveyor Registered under Surveyors Act 1929

[Signature]

SURVEYOR'S REFERENCE: 29543

General Manager/Authorised Person

[Signature]

INSTRUMENT SETTING OUT TERMS OF EASEMENTS, RESTRICTION ON THE USE OF LAND OR POSITIVE COVENANTS INTENDED TO BE CREATED PURSUANT TO SECTION 89B OF THE CONVEYANCING ACT 1919.

Plan: **DP776680**

Subdivision of lot 39 Section 3 deposited Plan 10048 covered by Council Clerk's Certificate No. 32/4853 of June 23, 1988.

PART 1 (Sheet 1 of 2 Sheets)

Full name and address of the proprietor of the land
 Corporate Uniforms and Promotional Supplies Pty. Ltd, a company duly incorporated and having its registered office at 245 Newbery Road, Chatswood N.S.W. 2067.
Full name and address of mortgagee of the land.
 A.N.Z. Bank,
 200 Victoria Road, Gladswille N.S.W. 2111.

1. Identity of easement, restriction or positive covenant firstly referred to in the above-mentioned plan.
 Easement for Sewerage Purposes over existing line of pipes.

Schedule of lots, etc. affected.

381 Name of Authority benefited

382 Restriction on Use

2. Identity of easement, restriction or positive covenant secondly referred to in the above-mentioned plan.
 Easement to Drain Water 1.25 wide

Schedule of lots, etc. affected.

381 Name of Authority benefited

382 Easement to Drain Water 1.25 wide

3. Identity of easement, restriction or positive covenant thirdly referred to in the above-mentioned plan.
 Easement for Sewerage Purposes over existing line of pipes.

Schedule of lots, etc. affected.

381 Name of Authority benefited

382 Restriction on Use



28-7-1988

10	20	30	40	50	60	70	Table of mm	110	120	130	140
----	----	----	----	----	----	----	-------------	-----	-----	-----	-----

DP776680

INSTRUMENT SETTING OUT TERMS OF EASEMENTS, RESTRICTION ON THE USE OF LAND OR POSITIVE COVENANTS INTENDED TO BE CREATED PURSUANT TO SECTION 89B OF THE CONVEYANCING ACT 1919.

PART 2 (Sheet 2 of 2 Sheets)

1. Terms of Easement firstly referred to in above-mentioned plan.
 Full and free right for every person who is at any time entitled to an estate or interest in possession in the land herein indicated as the dominant tenement or any part thereof with which the right shall be capable of enjoyment, and every person authorized by him, from time to time and at all times by means of pipes to drain sewage and other waste material and fluid in any quantities across and through the land herein indicated as the servient tenement, together with the right to use, for the purpose of the easement, any line of pipes already laid within the servient tenement for the purpose of drainage sewage or any pipe or pipes in replacement or in substitution therefor and together with the right for the grantee and every person authorized by him, with any tools, implements, or machinery, necessary for the purpose, to enter upon the servient tenement and to maintain there for any reasonable time for the purpose of laying, inspecting, cleansing, repairing, maintaining or renewing such pipe or any part thereof and for any of the aforesaid purposes to open the soil of the servient tenement to such extent as may be necessary provided that the grantee and the persons authorized by him will take all reasonable precautions to ensure as little disturbance as possible to the surface of the servient tenement and will restore that surface as nearly as practicable to its original condition and this easement shall not be released varied or modified without the consent of the Water Board.

2. Terms of Restriction on the use of the land secondly referred to in the above-mentioned plan.
 No building or other structure shall be erected, constructed or placed on the land shown as basement for Sewerage Purposes over existing line of Pipes without the prior consent in writing of the Water Board and the grantee shall not otherwise than in strict compliance with such conditions as the said Board may impose and this restriction shall not be released varied or modified without the consent of the said Board.

3. Name of person empowered to release, vary or modify Restriction or Positive Covenant thirdly referred to in the above-mentioned plan.
 The Council of the City of Parramatta its successors and assigns.

The Common Seal of Corporate Uniforms and Promotional Supplies Pty. Ltd. was heretofore affixed by Authority previously given by the Board of Directors in the presence of:

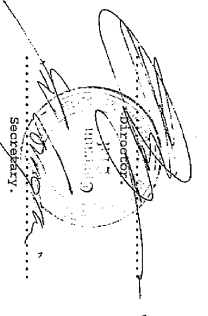

 Secretary

Witnessed by the said bank at Sydney by its Attorney
GRAHAM WILLIAM HOWARTH
 Solicitor
 and I, the said Attorney, saw that, having read and signed my copy of this document, the said bank and I, the said Attorney, signed in the Office of the Registrar-General Sydney No. 205 Book 3403 under which this document is recorded.

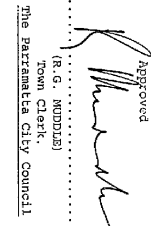
Approved

 R. G. KIMPEY
 Town Clerk
 The Parramatta City Council

REGISTERED 28-7-1988

This negative is a photograph made as a permanent record of a document in the custody of the Registrar-General this day, 1st August, 1988



**INSTRUMENT SETTING OUT THE TERMS OF EASEMENTS
AND RESTRICTIONS ON THE USE OF LAND INTENDED
TO BE CREATED PURSUANT TO SECTION 88B OF THE CONVEYANCING ACT 1919.
& SECTION 7.3 OF THE STRATA SCHEMES (FREEHOLD DEVELOPMENT) ACT 1973**

SP65573

Plan of Subdivision of Lot 1 in
D.P. 1012970 covered by Council
Certificate No. 2001/711
Date: 17 May 2001

(Sheet 1 of 3)

PART 1

Full name and address of the
Proprietor of the land:

Leonie Mary Hickey
8 Banks Road
CASTLE HILL NSW 2154

Full name and address of Mortgagee
of land:

GIO Finance
Level 6, 154 Sussex Street
SYDNEY NSW 2000

1. Identity of Easement firstly
referred to in the abovementioned
plan:

Positive Covenant

SCHEDULE OF LOTS ETC AFFECTED

Lots Burdened

Authority Benefited

Common Property
S.P.

Parramatta City Council

2. Identity of Easement or Restriction
secondly referred to in the abovementioned
plan:

Restriction on the Use of Land

SCHEDULE OF LOTS ETC AFFECTED

Lots Burdened

Authority Benefited

Common Property
S.P.

Parramatta City Council

**INSTRUMENT SETTING OUT THE TERMS OF EASEMENTS
AND RESTRICTIONS ON THE USE OF LAND INTENDED
TO BE CREATED PURSUANT TO SECTION 88B OF THE CONVEYANCING ACT 1919.
& SECTION 7.3 OF THE STRATA SCHEMES (FREEHOLD DEVELOPMENT) ACT 1973**

SP65573

Plan of Subdivision of Lot 1 in
D.P. 1012970 covered by Council
Certificate No. DA01 711
Date: 17 MAY 2001

(Sheet 2 of 3)

PART 2

Terms of Positive Covenant firstly referred to in the abovementioned plan.

1. The registered proprietor of the lot(s) hereby burdened will in respect of the system:
 - (a) keep the system clean and free from silt, rubbish and debris
 - (b) maintain and repair at the sole expense of the registered proprietors the whole of the system so that it functions in a safe and efficient manner
 - (c) permit the Council or its authorised agents from time to time and upon giving reasonable notice (but at any time and without notice in the case of an emergency) to enter and inspect the land for the compliance with the requirements of this covenant
 - (d) comply with the terms of any written notice issued by the Council in respect of the requirements of this covenant within the time stated in the notice.
2. Pursuant to Section 88F(3) of the Conveyancing Act 1919, the Council shall have the following additional powers:
 - (a) in the event that the registered proprietor fails to comply with the terms of any written notice issued by the Council as set out above the Council or its authorised agents may enter the land with all necessary materials and equipment and carry out any work which the Council in its discretion considers reasonable to comply with the said notice referred to in part 1(d) above.
 - (b) the Council may recover from the registered proprietor in a Court of competent jurisdiction:
 - (i) any expense reasonably incurred by it in exercising its powers under sub-paragraph (i) hereof. Such expense shall include reasonable wages for the Council's employees engaged in effecting the work referred to in (i) above, supervising and administering the said work together with costs, reasonably estimated by the Council, for the use of materials, machinery, tools and equipment in conjunction with the said work.
 - (ii) legal costs on an indemnity basis for issue of the said notices and recovery of the said costs and expenses together with the costs and expenses of registration of a covenant charge pursuant to Section 88F of the Act or providing any certificate required pursuant to Section 88G of the Act or obtaining any injunction pursuant to Section 88H of the Act.

Name of Authority having the power to release, vary or modify the Positive Covenant firstly referred to is Parramatta City Council.

**INSTRUMENT SETTING OUT THE TERMS OF EASEMENTS
AND RESTRICTIONS ON THE USE OF LAND INTENDED
TO BE CREATED PURSUANT TO SECTION 88B OF THE CONVEYANCING ACT 1919.
& SECTION 7.3 OF THE STRATA SCHEMES (FREEHOLD DEVELOPMENT) ACT 1973**

SP65573

Plan of Subdivision of Lot 1 in
D.P. 1012970 covered by Council
Certificate No. DA01/711
Date: 17 MAY 2001

(Sheet 3 of 3)

Terms of Restriction on the Use of Land secondly referred to in the abovementioned plan

The registered proprietor shall not make or permit or suffer the making of any alterations to any on-site stormwater detention system which is, or shall be, constructed on the lot(s) burdened without the prior consent in writing of Parramatta City Council. The expression "on-site stormwater detention system" shall include all ancillary gutters, pipes, drains, walls, kerbs, pits, grates, tanks, chambers, basins and surfaces designed to temporarily detain stormwater as well as all surfaces graded to direct stormwater to the temporary storage. Any on-site stormwater detention system constructed on the lot(s) burdened is hereafter referred to as "the system".

Name of Authority having the power to release, vary or modify the Restriction secondly referred to is Parramatta City Council.

SIGNED in my presence by)
LEONIE MARY HICKEY)
who is personally known to me)

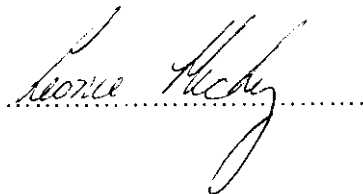

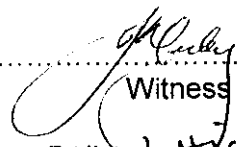

Witness
JOHN HICKEY
8 BANK ST
CASTLEHILL

SIGNATURES AND SEALS OF GIO FINANCE

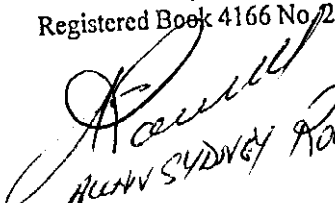
SIGNED in my presence for GIO FINANCE
LIMITED (ACN 002 812 704) by its Attorney
PETER KEARNS
who is personally known to me and who holds
the position of
NATIONAL LENDING MANAGER
GIO FINANCE LIMITED (ACN 002 812 704)
pursuant to the Power of Attorney dated
9 May 1997
Registered Book 4166 No 292

ALAN SYDNEY ROWSE

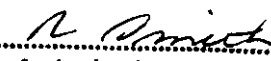
Parramatta City Council

Authorized Person
ROSLYN SMITH
5149 COORDINATOR

REGISTERED  24.5.2001

Lodger Details

Lodger Code 503696B
Name KEMPS PETERSONS LEGAL PTY LTD
Address PO BOX K372
HAYMARKET 1240
Lodger Box 1W
Email KAVITA.PRASAD@KPLG.COM.AU
Reference 225002 - EPP -

Land Registry Document Identification

AT697022

STAMP DUTY:

Consolidation/Change of By-laws

Jurisdiction NEW SOUTH WALES

Privacy Collection Statement

The information in this form is collected under statutory authority and used for the purpose of maintaining publicly searchable registers and indexes.

Land Title Reference	Part Land Affected?	Land Description
CP/SP65573	N	

Owners Corporation

THE OWNERS - STRATA PLAN NO. SP65573
Other legal entity

Meeting Date

27/10/2023

Added by-law No.

Details SPECIAL BY-LAW 1

Amended by-law No.

Details NOT APPLICABLE

Repealed by-law No.

Details NOT APPLICABLE

The subscriber requests the Registrar-General to make any necessary recording in the Register to give effect to this instrument, in respect of the land or interest described above.

Attachment

See attached Conditions and Provisions

See attached Approved forms

Execution

The Certifier has taken reasonable steps to verify the identity of the applicant or his, her or its administrator or attorney.

The Certifier holds a properly completed Client Authorisation for the Conveyancing Transaction including this Registry Instrument or Document.

The Certifier has retained the evidence supporting this Registry Instrument or Document.

The Certifier has taken reasonable steps to ensure that this Registry Instrument or Document is correct and compliant with relevant legislation and any Prescribed Requirement.

Executed on behalf of THE OWNERS - STRATA PLAN NO. SP65573

Signer Name MICHELLE MONICA KUMAR

Signer Organisation KEMPS PETERSONS LEGAL PTY LTD

Signer Role PRACTITIONER CERTIFIER

Execution Date 15/12/2023

ANNEXURE A

STRATA PLAN 65573

BY-LAWS

The seal of The Owners – Strata Plan No. 65573 was affixed on 15 December 2023 in the presence of the following person(s) authorised by section 273 Strata Schemes Management Act 2015 to attest the affixing of the seal.

Signature: 

Electronic signature of me, Angela Capri, affixed by me, or at my direction, on 15 December 2023

Authority: Licensed Strata Managing Agent,
[Licence No. 723973]
BCS Strata Management P/L



STRATA PLAN 65573

TABLE OF CONTENTS

By-law 1 - Noise.....	3
By-law 2 - Vehicles.....	3
By-law 3 - Obstruction of common property.....	3
By-law 4 - Damage to lawns and plants on common property	3
By-law 5 - Damage to common property	3
By-law 6 - Behaviour of owners and occupiers	4
By-law 7 - Children playing on common property in building.....	4
By-law 8 - Behaviour of invitees.....	4
By-law 9 - Depositing rubbish and other material on common property	4
By-law 10 - Drying of laundry items.....	4
By-law 11 - Cleaning windows and doors.....	4
By-law 12 - Storage of inflammable liquids and other substances and materials	4
By-law 13 - Moving furniture and other objects on or through common property	5
By-law 14 - Floor coverings	5
By-law 15 - Garbage disposal.....	5
By-law 16 - Keeping of animals	6
By-law 17 - Appearance of lot	6
By-law 18 - Change in use of lot to be notified	6
By-law 19 - Provision of amenities or services.....	6
By-law 20 - Air conditioner lot 7	6
Special by-law no. 1 – Previously installed shade or shelter structures – lot 3 and lot 5.....	9

By-law 1 - Noise

An owner or occupier of a lot must not create any noise on a lot or the common property likely to interfere with the peaceful enjoyment of the owner or occupier of another lot or of any person lawfully using common property.

By-law 2 - Vehicles

An owner or occupier of a lot must not park or stand any motor or other vehicle on common property except with the prior written approval of the owners corporation.

By-law 3 - Obstruction of common property

An owner or occupier of a lot must not obstruct lawful use of common property by any person except on a temporary and non-recurring basis.

By-law 4 - Damage to lawns and plants on common property

An owner or occupier of a lot must not, except with the prior written approval of the owners corporation:

- (a) damage any lawn, garden, tree, shrub, plant or flower being part of or situated on common property, or
- (b) use for his or her own purposes as a garden any portion of the common property.

By-law 5 - Damage to common property

(1) An owner or occupier of a lot must not mark, paint, drive nails or screws or the like into, or otherwise damage or deface, any structure that forms part of the common property except with the prior written approval of the owners corporation.

(2) An approval given by the owners corporation under subclause (1) cannot authorise any additions to the common property.

(3) This by-law does not prevent an owner or person authorised by an owner from installing:

- (a) any locking or other safety device for protection of the owner's lot against intruders or to improve safety within the owner's lot, or
- (b) any screen or other device to prevent entry of animals or insects on the lot, or
- (c) any structure or device to prevent harm to children, or
- (d) any device used to affix decorative items to the internal surfaces of walls in the owner's lot.

(4) Any such locking or safety device, screen, other device or structure must be installed in a competent and proper manner and must have an appearance, after it has been installed, in keeping with the appearance of the rest of the building.

(5) Despite section 62, the owner of a lot must:

- (a) maintain and keep in a state of good and serviceable repair any installation or structure referred to in subclause (3) that forms part of the common property and that services the lot, and
- (b) repair any damage caused to any part of the common property by the installation or removal of any locking or safety device, screen, other device or structure referred to in subclause (3) that forms part of the common property and that services the lot.

By-law 6 - Behaviour of owners and occupiers

An owner or occupier of a lot when on common property must be adequately clothed and must not use language or behave in a manner likely to cause offence or embarrassment to the owner or occupier of another lot or to any person lawfully using common property.

By-law 7 - Children playing on common property in building

An owner or occupier of a lot must not permit any child of whom the owner or occupier has control to play on common property within the building or, unless accompanied by an adult exercising effective control, to be or to remain on common property comprising a laundry, car parking area or other area of possible danger or hazard to children.

By-law 8 - Behaviour of invitees

An owner or occupier of a lot must take all reasonable steps to ensure that invitees of the owner or occupier do not behave in a manner likely to interfere with the peaceful enjoyment of the owner or occupier of another lot or any person lawfully using common property.

By-law 9 - Depositing rubbish and other material on common property

An owner or occupier of a lot must not deposit or throw on the common property any rubbish, dirt, dust or other material or discarded item except with the prior written approval of the owners corporation.

By-law 10 - Drying of laundry items

An owner or occupier of a lot must not, except with the prior written approval of the owners corporation, hang any washing, towel, bedding, clothing or other article on any part of the parcel in such a way as to be visible from outside the building other than on any lines provided by the owners corporation for the purpose and there only for a reasonable period.

By-law 11 - Cleaning windows and doors

An owner or occupier of a lot must keep clean all exterior surfaces of glass in windows and doors on the boundary of the lot, including so much as is common property, unless:

- (a) the owners corporation resolves that it will keep the glass or specified part of the glass clean, or
- (b) that glass or part of the glass cannot be accessed by the owner or occupier of the lot safely or at all.

By-law 12 - Storage of inflammable liquids and other substances and materials

(1) An owner or occupier of a lot must not, except with the prior written approval of the owners corporation, use or store on the lot or on the common property any inflammable chemical, liquid or gas or other inflammable material.

(2) This by-law does not apply to chemicals, liquids, gases or other material used or intended to be used for domestic purposes, or any chemical, liquid, gas or other material in a fuel tank of a motor vehicle or internal combustion engine.

By-law 13 - Moving furniture and other objects on or through common property

(1) An owner or occupier of a lot must not transport any furniture or large object through or on common property within the building unless sufficient notice has first been given to the executive committee so as to enable the executive committee to arrange for its nominee to be present at the time when the owner or occupier does so.

(2) An owners corporation may resolve that furniture or large objects are to be transported through or on the common property (whether in the building or not) in a specified manner.

(3) If the owners corporation has specified, by resolution, the manner in which furniture or large objects are to be transported, an owner or occupier of a lot must not transport any furniture or large object through or on common property except in accordance with that resolution.

By-law 14 - Floor coverings

(1) An owner of a lot must ensure that all floor space within the lot is covered or otherwise treated to an extent sufficient to prevent the transmission from the floor space of noise likely to disturb the peaceful enjoyment of the owner or occupier of another lot.

(2) This by-law does not apply to floor space comprising a kitchen, laundry, lavatory or bathroom.

By-law 15 - Garbage disposal

(1) An owner or occupier of a lot in a strata scheme that does not have shared receptacles for garbage, recyclable material or waste:

(a) must maintain such receptacles within the lot, or on such part of the common property as may be authorised by the owners corporation, in clean and dry condition and (except in the case of receptacles for recyclable material) adequately covered, and

(b) must ensure that before refuse, recyclable material or waste is placed in the receptacles it is, in the case of refuse, securely wrapped or, in the case of tins or other containers, completely drained, or, in the case of recyclable material or waste, separated and prepared in accordance with the applicable recycling guidelines, and

(c) for the purpose of having the garbage, recyclable material or waste collected, must place the receptacles within an area designated for that purpose by the owners corporation and at a time not more than 12 hours before the time at which garbage, recyclable material or waste is normally collected, and

(d) when the garbage, recyclable material or waste has been collected, must promptly return the receptacles to the lot or other area referred to in paragraph (a),

(e) must not place any thing in the receptacles of the owner or occupier of any other lot except with the permission of that owner or occupier, and

(f) must promptly remove any thing which the owner, occupier or garbage or recycling collector may have spilled from the receptacles and must take such action as may be necessary to clean the area within which that thing was spilled.

(2) An owner or occupier of a lot in a strata scheme that has shared receptacles for garbage, recyclable material or waste:

(a) must ensure that before refuse, recyclable material or waste is placed in the receptacles it is, in the case of refuse, securely wrapped or, in the case of tins or other containers, completely drained, or, in the case of recyclable material or waste, separated and prepared in accordance with the applicable recycling guidelines, and

(b) must promptly remove any thing which the owner, occupier or garbage or recycling collector may have spilled in the area of the receptacles and must take such action as may be necessary to clean the area within which that thing was spilled.

By-law 16 - Keeping of animals

(1) Subject to section 49 (4), an owner or occupier of a lot must not, without the prior written approval of the owners corporation, keep any animal (except fish kept in a secure aquarium on the lot) on the lot or the common property.

(2) The owners corporation must not unreasonably withhold its approval of the keeping of an animal on a lot or the common property.

By-law 17 - Appearance of lot

(1) The owner or occupier of a lot must not, without the prior written approval of the owners corporation, maintain within the lot anything visible from outside the lot that, viewed from outside the lot, is not in keeping with the rest of the building.

(2) This by-law does not apply to the hanging of any washing, towel, bedding, clothing or other article as referred to in by-law 10.

By-law 18 - Change in use of lot to be notified

An occupier of a lot must notify the owners corporation if the occupier changes the existing use of the lot in a way that may affect the insurance premiums for the strata scheme (for example, if the change of use results in a hazardous activity being carried out on the lot, or results in the lot being used for commercial or industrial purposes rather than residential purposes).

By-law 19 - Provision of amenities or services

(1) The owners corporation may, by special resolution, determine to enter into arrangements for the provision of the following amenities or services to one or more of the lots, or to the owners or occupiers of one or more of the lots:

- (a) window cleaning,
- (b) garbage disposal and recycling services,
- (c) electricity, water or gas supply,
- (d) telecommunication services (for example, cable television).

(2) If the owners corporation makes a resolution referred to in subclause (1) to provide an amenity or service to a lot or to the owner or occupier of a lot, it must indicate in the resolution the amount for which, or the conditions on which, it will provide the amenity or service.

Note Section 111 of the Act provides that an owners corporation may enter into an agreement with an owner or occupier of a lot for the provision of amenities or services by it to the lot or to the owner or occupier.

By-law 20 - Air conditioner lot 7

The Owner for the time being of Lot 7 shall be entitled to exclusive use and enjoyment of that part of the Common Property designated in the plan annexed hereto and marked "B" subject to the following terms and conditions:

- (a) Such Owner shall not permit or suffer to be used that part of the Common Property designated to them for any purpose other than for the installation of air conditioning ducting and skylight ducting.
- (b) Such Owner shall at their own expense install and maintain and keep in good serviceable repair such ducting and shall ensure that no damage is caused to the Common Property area where the ducting is installed and shall be liable to repair and maintain that part of the Common Property where the ducting is installed.
- (c) Such Owner shall ensure at all times that the air conditioner be operated in compliance with all relevant noise pollution laws or ordinances and shall in addition ensure that no disturbance is caused to any other Owner of any Lot that forms part of the Strata Scheme.
- (d) If such Owner or any Lessee of such Owner fail to comply with the terms and conditions contained or implied by this By-Law the Owners Corporation may by notice in writing pursuant to an Ordinary Resolution require them to rectify that breach and if that breach is not rectified within seven (7) days after service upon them of the Notice, the entitlement to exclusive use and enjoyment conferred by this By-Law shall terminate on expiry of the last mentioned period.
- (e) The Owner shall meet the cost of creation of this By-Law and any subsequent enforcement costs.

Req:R597659 /Doc:DL AA364330 /Rev:17-Feb-2004 /NSW LRS /Pgs:ALL /Prt:29-Nov-2023 11:11 /Seq:3 of 3
 © Office of the Registrar-General /Src:InfoTrack /Ref:225002
 U3 11:55 FAX 61 2 98682383 BEECROFT ROAD EPPING 002

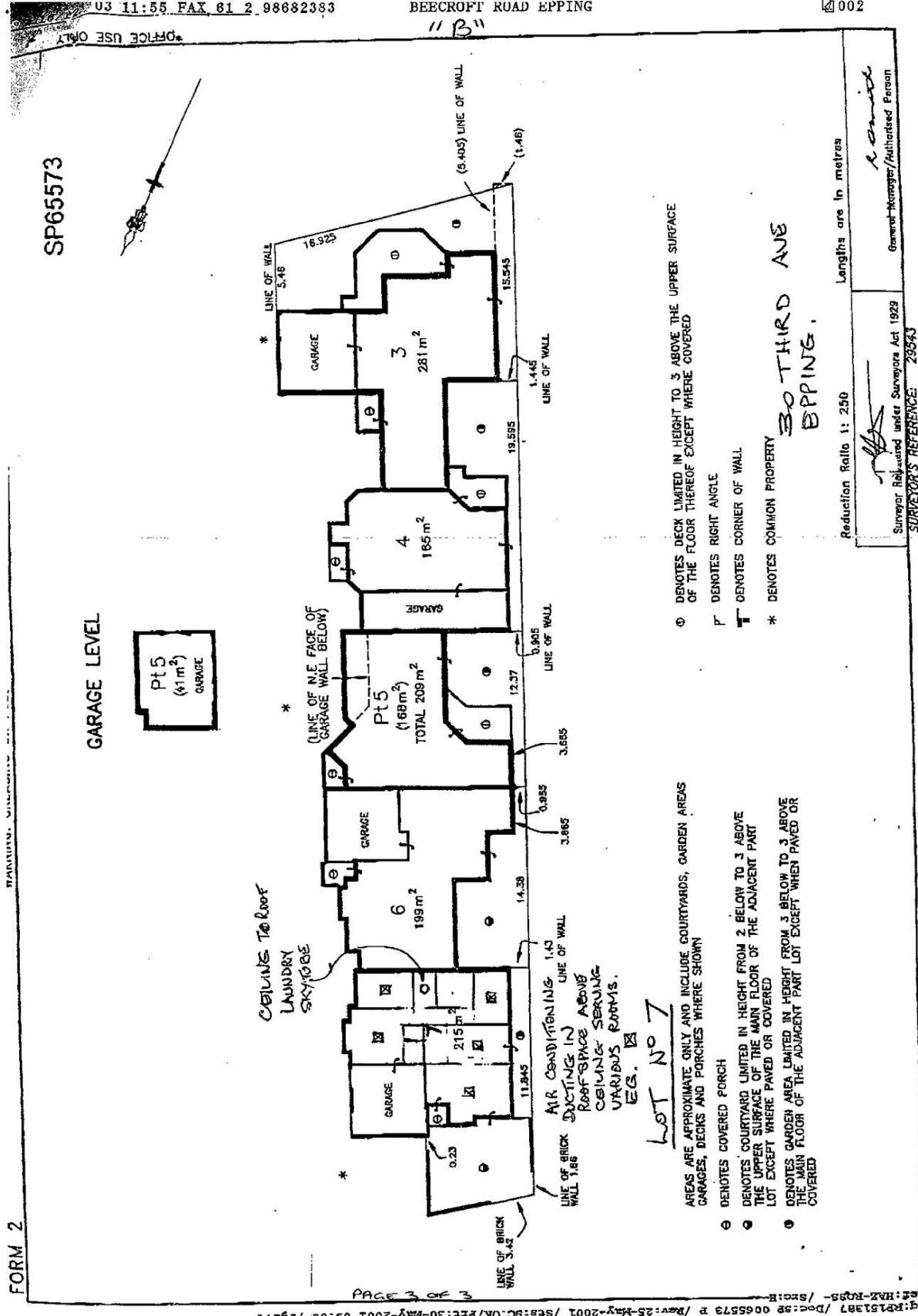

FORM 2

PAGE 3 OF 3

Special by-law no. 1 – Previously installed shade or shelter structures – lot 3 and lot 5

1.1 This by-law relates to lots in the strata scheme with shade or shelter structures which at the date of this by-law have been installed.

1.2 '**Owner**' means an owner of a lot which has had a shade or shelter structure installed prior to the date when this by-law was made.

1.3 The shade or shelter structure referred to in this by-law means the shade or shelter structure and associated supporting posts, brackets and restrainers utilized in the installation of the said shade or shelter structure.

1.4 A owner of a lot shall:

1.4.1 Have a special privilege in respect of the common property to install and keep the shade or shelter structure in and on the common property, and a special privilege in respect to common property to supporting posts, brackets and restrainers on and through common property for the attachment and support of the structure or shelter and shall have the exclusive use of those parts of the common property occupied by the shade or shelter structure.

1.4.2 Properly maintain and keep the common property in which the shade or shelter structure and associated supporting posts, brackets and restrainers is attached in a state of good and serviceable repair.

1.4.3 Properly maintain and keep the shade or shelter structure and associated supporting posts, brackets and restrainers in a state of good and serviceable repair.

1.4.4 Be responsible for any damage occasioned to the common property by the attachment on or through it by the shade or shelter structure and associated supporting posts, brackets and restrainers.

1.4.5 Not be permitted to replace the shade or shelter structure without the approval of the Owners Corporation.

1.5 With respect to any shade or shelter structure installed prior to the making of this by-law:

1.5.1 An owner shall inform the Owners Corporation in writing that such installation has been effected and such advice shall include details of the size of the structure and location on common property.

1.5.2 The Owners Corporation may reasonably require the owner to ameliorate any adverse impact on the peaceful enjoyment of any owner or occupier of another lot or the appearance of the building.

1.5.3 Owners hereby indemnify and keep indemnified the Owners Corporation in respect of that part of the common property benefiting the owners against all actions, proceedings, claims, demands, costs, damages and expenses which may be incurred by or brought or made against the Owners Corporation and arising directly or indirectly out of the use of the common property by the owners pursuant to this by-law.

The seal of The Owners – Strata Plan No. 65573
was affixed on 15 December 2023
in the presence of the following person(s) authorised by
section 273 Strata Schemes Management Act 2015
to attest the affixing of the seal.

Signature: 

Electronic signature of me, Angela Capri,
affixed by me, or at my direction, on 15 December 2023

Authority: Licensed Strata Managing Agent,
[Licence No. 723973]
BCS Strata Management P/L



Approved Form 23

Attestation

The common seal of the Owners – Strata Plan No 65573 was affixed on 15 December 2023 in the presence of the following person(s) authorised by section 273 *Strata Schemes Management Act 2015* to attest the affixing of the seal.

Signature: 

Electronic signature of me, Angela Capri,
affixed by me, or at my direction,
on 15 December 2023

Authority: Licensed Strata Managing Agent,
[Licence No. 723973]
BCS Strata Management P/L



Approved Form 10
Certificate re Initial Period

The owners corporation certifies that in respect of the strata scheme:

that the initial period has expired.

~~the original proprietor owns all of the lots in the strata scheme and any purchaser under an exchanged contract for the purchase of a lot in the scheme has consented to any plan or dealing being lodged with this certificate.~~

The seal of The Owners – Strata Plan No. 65573
was affixed on 15 December 2023
in the presence of the following person(s) authorised by
section 273 Strata Schemes Management Act 2015
to attest the affixing of the seal.

Signature: 

Electronic signature of me, Angela Capri,
affixed by me, or at my direction, on 15 December 2023

Authority: Licensed Strata Managing Agent,
[Licence No. 723973]
BCS Strata Management P/L



Lodger Details

Lodger Code 503650C
Name JLAWYERS
Address EQUINOX
STR 3, 94-98 RAMSGATE AV
BONDI BEACH 2026
Lodger Box 1W
Email MONIKA@JLAWYERSPTYLTD.COM.AU
Reference MC20240420

Land Registry Document Identification

AU598430

STAMP DUTY:

Consolidation/Change of By-laws

Jurisdiction NEW SOUTH WALES

Privacy Collection Statement

The information in this form is collected under statutory authority and used for the purpose of maintaining publicly searchable registers and indexes.

Land Title Reference	Part Land Affected?	Land Description
CP/SP65573	N	

Owners Corporation

THE OWNERS - STRATA PLAN NO. SP65573
Other legal entity

Meeting Date

28/08/2024

Added by-law No.

Details Special By-law No. 2

Repealed by-law No.

Details N/A

Amended by-law No.

Details N/A

The subscriber requests the Registrar-General to make any necessary recording in the Register to give effect to this instrument, in respect of the land or interest described above.

Attachment

See attached Conditions and Provisions

See attached Approved forms

Execution

The Certifier has taken reasonable steps to verify the identity of the applicant or his, her or its administrator or attorney.

The Certifier holds a properly completed Client Authorisation for the Conveyancing Transaction including this Registry Instrument or Document.

The Certifier has retained the evidence supporting this Registry Instrument or Document.

The Certifier has taken reasonable steps to ensure that this Registry Instrument or Document is correct and compliant with relevant legislation and any Prescribed Requirement.

Executed on behalf of THE OWNERS - STRATA PLAN NO. SP65573

Signer Name MONIKA JANDREK

Signer Organisation JLAWYERS PTY. LIMITED

Signer Role PRACTITIONER CERTIFIER

Execution Date 19/11/2024

ANNEXURE TO CONSOLIDATION/CHANGE OF BY-LAWS
CONDITIONS & PROVISIONS
THE OWNERS – STRATA PLAN NO 65573

Consolidated Strata By-Laws

The Owners – Strata Plan No. 65573

28 – 30 Third Avenue Epping NSW 2121



Signature: .....

Name: Mallory Costen

Authority: Strata Managing Agent

ANNEXURE TO CONSOLIDATION/CHANGE OF BY-LAWS
CONDITIONS & PROVISIONS
THE OWNERS – STRATA PLAN NO 65573

Table of Contents as at 18.11.2024

1. Noise	3
2. Vehicles	3
3. Obstruction of common property	3
4. Damage to lawns and plants on common property	3
5. Damage to common property	3
6. Behaviour of owners and occupiers	4
7. Children playing on common property in building	4
8. Behaviour of invitees	4
9. Depositing rubbish and other material on common property	4
10. Drying of laundry items	4
11. Cleaning windows and doors	4
12. Storage of inflammable liquids and other substances and materials	5
13. Moving furniture and other objects on or through common property	5
14. Floor coverings	5
15. Garbage disposal	5
16. Keeping of animals	6
17. Appearance of lot	6
18. Change in use of lot to be notified	6
19. Provision of amenities or services	6
20. Air-Conditioner (Lot 7)	7
Special By-Law No. 1 – Previously installed shade or shelter structures (Lots 3 & 5)	9
Special By-Law No. 2 – By-law for Exclusive Use (Lot 3)	10

ANNEXURE TO CONSOLIDATION/CHANGE OF BY-LAWS
CONDITIONS & PROVISIONS
THE OWNERS – STRATA PLAN NO 65573

1. Noise

An owner or occupier of a lot must not create any noise on a lot or the common property likely to interfere with the peaceful enjoyment of the owner or occupier of another lot or of any person lawfully using common property.

2. Vehicles

An owner or occupier of a lot must not park or stand any motor or other vehicle on common property except with the prior written approval of the owners corporation.

3. Obstruction of common property

An owner or occupier of a lot must not obstruct lawful use of common property by any person except on a temporary and non-recurring basis.

4. Damage to lawns and plants on common property

An owner or occupier of a lot must not, except with the prior written approval of the owners corporation:

- (a) damage any lawn, garden, tree, shrub, plant or flower being part of or situated on common property, or
- (b) use for his or her own purposes as a garden any portion of the common property.

5. Damage to common property

- (1) An owner or occupier of a lot must not mark, paint, drive nails or screws or the like into, or otherwise damage or deface, any structure that forms part of the common property except with the prior written approval of the owners corporation.
- (2) An approval given by the owners corporation under subclause (1) cannot authorise any additions to the common property.
- (3) This by-law does not prevent an owner or person authorised by an owner from installing:
 - (a) any locking or other safety device for protection of the owner's lot against intruders or to improve safety within the owner's lot, or
 - (b) any screen or other device to prevent entry of animals or insects on the lot, or
 - (c) any structure or device to prevent harm to children, or
 - (d) any device used to affix decorative items to the internal surfaces of walls in the owner's lot.
- (4) Any such locking or safety device, screen, other device or structure must be installed in a competent and proper manner and must have an appearance, after it has been installed, in keeping with the appearance of the rest of the building.
- (5) Despite section 62, the owner of a lot must:
 - (a) maintain and keep in a state of good and serviceable repair any installation or structure referred to in subclause (3) that forms part of the common property and that services the lot, and

ANNEXURE TO CONSOLIDATION/CHANGE OF BY-LAWS
CONDITIONS & PROVISIONS
THE OWNERS – STRATA PLAN NO 65573

- (b) repair any damage caused to any part of the common property by the installation or removal of any locking or safety device, screen, other device or structure referred to in subclause (3) that forms part of the common property and that services the lot.

6. Behaviour of owners and occupiers

An owner or occupier of a lot when on common property must be adequately clothed and must not use language or behave in a manner likely to cause offence or embarrassment to the owner or occupier of another lot or to any person lawfully using common property.

7. Children playing on common property in building

An owner or occupier of a lot must not permit any child of whom the owner or occupier has control to play on common property within the building or, unless accompanied by an adult exercising effective control, to be or to remain on common property comprising a laundry, car parking area or other area of possible danger or hazard to children.

8. Behaviour of invitees

An owner or occupier of a lot must take all reasonable steps to ensure that invitees of the owner or occupier do not behave in a manner likely to interfere with the peaceful enjoyment of the owner or occupier of another lot or any person lawfully using common property.

9. Depositing rubbish and other material on common property

An owner or occupier of a lot must not deposit or throw on the common property any rubbish, dirt, dust or other material or discarded item except with the prior written approval of the owners corporation.

10. Drying of laundry items

An owner or occupier of a lot must not, except with the prior written approval of the owners corporation, hang any washing, towel, bedding, clothing or other article on any part of the parcel in such a way as to be visible from outside the building other than on any lines provided by the owners corporation for the purpose and there only for a reasonable period.

11. Cleaning windows and doors

An owner or occupier of a lot must keep clean all exterior surfaces of glass in windows and doors on the boundary of the lot, including so much as is common property, unless:

- (a) the owners corporation resolves that it will keep the glass or specified part of the glass clean, or
(b) that glass or part of the glass cannot be accessed by the owner or occupier of the lot safely or at all.

ANNEXURE TO CONSOLIDATION/CHANGE OF BY-LAWS
CONDITIONS & PROVISIONS
THE OWNERS – STRATA PLAN NO 65573

12. Storage of inflammable liquids and other substances and materials

- (1) An owner or occupier of a lot must not, except with the prior written approval of the owners corporation, use or store on the lot or on the common property any inflammable chemical, liquid or gas or other inflammable material.
- (2) This by-law does not apply to chemicals, liquids, gases or other material used or intended to be used for domestic purposes, or any chemical, liquid, gas or other material in a fuel tank of a motor vehicle or internal combustion engine.

13. Moving furniture and other objects on or through common property

- (1) An owner or occupier of a lot must not transport any furniture or large object through or on common property within the building unless sufficient notice has first been given to the executive committee so as to enable the executive committee to arrange for its nominee to be present at the time when the owner or occupier does so.
- (2) An owners corporation may resolve that furniture or large objects are to be transported through or on the common property (whether in the building or not) in a specified manner.
- (3) If the owners corporation has specified, by resolution, the manner in which furniture or large objects are to be transported, an owner or occupier of a lot must not transport any furniture or large object through or on common property except in accordance with that resolution.

14. Floor coverings

- (1) An owner of a lot must ensure that all floor space within the lot is covered or otherwise treated to an extent sufficient to prevent the transmission from the floor space of noise likely to disturb the peaceful enjoyment of the owner or occupier of another lot.
- (2) This by-law does not apply to floor space comprising a kitchen, laundry, lavatory or bathroom.

15. Garbage disposal

- (1) An owner or occupier of a lot in a strata scheme that does not have shared receptacles for garbage, recyclable material or waste:
 - (a) must maintain such receptacles within the lot, or on such part of the common property as may be authorised by the owners corporation, in clean and dry condition and (except in the case of receptacles for recyclable material) adequately covered, and
 - (b) must ensure that before refuse, recyclable material or waste is placed in the receptacles it is, in the case of refuse, securely wrapped or, in the case of tins or other containers, completely drained, or, in the case of recyclable material or waste, separated and prepared in accordance with the applicable recycling guidelines, and
 - (c) for the purpose of having the garbage, recyclable material or waste collected, must place the receptacles within an area designated for that purpose by the owners corporation and at a time

ANNEXURE TO CONSOLIDATION/CHANGE OF BY-LAWS
CONDITIONS & PROVISIONS
THE OWNERS – STRATA PLAN NO 65573

- not more than 12 hours before the time at which garbage, recyclable material or waste is normally collected, and
- (d) when the garbage, recyclable material or waste has been collected, must promptly return the receptacles to the lot or other area referred to in paragraph (a),
 - (e) must not place any thing in the receptacles of the owner or occupier of any other lot except with the permission of that owner or occupier, and
 - (f) must promptly remove any thing which the owner, occupier or garbage or recycling collector may have spilled from the receptacles and must take such action as may be necessary to clean the area within which that thing was spilled.
- (2) An owner or occupier of a lot in a strata scheme that has shared receptacles for garbage, recyclable material or waste:
- (a) must ensure that before refuse, recyclable material or waste is placed in the receptacles it is, in the case of refuse, securely wrapped or, in the case of tins or other containers, completely drained, or, in the case of recyclable material or waste, separated and prepared in accordance with the applicable recycling guidelines, and
 - (b) must promptly remove any thing which the owner, occupier or garbage or recycling collector may have spilled in the area of the receptacles and must take such action as may be necessary to clean the area within which that thing was spilled.

16. Keeping of animalsⁱ

- (1) Subject to section 49 (4), an owner or occupier of a residential lot must not, without the prior written approval of the owners corporation, keep any animal (except fish kept in a secure aquarium on the lot) on the lot or the common property.
- (2) The owners corporation must not unreasonably withhold its approval of the keeping of an animal on a residential lot or the common property.

17. Appearance of lot

- (1) The owner or occupier of a lot must not, without the prior written approval of the owners corporation, maintain within the lot anything visible from outside the lot that, viewed from outside the lot, is not in keeping with the rest of the building.
- (2) This by-law does not apply to the hanging of any washing, towel, bedding, clothing or other article as referred to in by-law 10.

18. Change in use of lot to be notified

An occupier of a lot must notify the owners corporation if the occupier changes the existing use of the lot in a way that may affect the insurance premiums for the strata scheme (for example, if the change of use results in a hazardous activity being carried out on the lot, or results in the lot being used for commercial or industrial purposes rather than residential purposes).

19. Provision of amenities or services

ANNEXURE TO CONSOLIDATION/CHANGE OF BY-LAWS
CONDITIONS & PROVISIONS
THE OWNERS – STRATA PLAN NO 65573

- (1) The owners corporation may, by special resolution, determine to enter into arrangements for the provision of the following amenities or services to one or more of the lots, or to the owners or occupiers of one or more of the lots:
 - (a) window cleaning,
 - (b) garbage disposal and recycling services,
 - (c) electricity, water or gas supply,
 - (d) telecommunication services (for example, cable television).
- (2) If the owners corporation makes a resolution referred to in subclause (1) to provide an amenity or service to a lot or to the owner or occupier of a lot, it must indicate in the resolution the amount for which, or the conditions on which, it will provide the amenity or service.

Note.

Section 111 of the Act provides that an owners corporation may enter into an agreement with an owner or occupier of a lot for the provision of amenities or services by it to the lot or to the owner or occupier.

20. Air-Conditioner (Lot 7)

The Owner for the time being of Lot 7 shall be entitled to exclusive use and enjoyment of that part of the Common Property designated in the plan annexed hereto and marked "B" subject to the following terms and conditions:

- (a) Such Owner shall not permit or suffer to be used that part of the Common Property designated to them for any purpose other than for the installation of air conditioning ducting and skylight ducting.
- (b) Such Owner shall at their own expense install and maintain and keep in good serviceable repair such ducting and shall ensure that no damage is caused to the Common Property area where the ducting is installed and shall be liable to repair and maintain that part of the Common Property where the ducting is installed.
- (c) Such Owner shall ensure at all times that the air conditioner be operated in compliance with all relevant noise pollution laws or ordinances and shall in addition ensure that no disturbance is caused to any other Owner of any Lot that forms part of the Strata Scheme.
- (d) If such Owner or any Lessee of such Owner fail to comply with the terms and conditions contained or implied by this By-Law the Owners Corporation may by notice in writing pursuant to an Ordinary Resolution require them to rectify that breach and if that breach is not rectified within seven (7) days after service upon them of the Notice, the entitlement to exclusive use and enjoyment conferred by this By-Law shall terminate on expiry of the last mentioned period.
- (e) The Owner shall meet the cost of creation of this By-Law and any subsequent enforcement costs.

ANNEXURE TO CONSOLIDATION/CHANGE OF BY-LAWS
CONDITIONS & PROVISIONS
THE OWNERS – STRATA PLAN NO 65573

Special By-Law No. 1 – Previously installed shade or shelter structures (Lots 3 & 5)ⁱⁱ

- 1.1 This by-law relates to lots in the strata scheme with shade or shelter structures which at the date of this by-law have been installed.
- 1.2 '**Owner**' means an owner of a lot which has had a shade or shelter structure installed prior to the date when this by-law was made.
- 1.3 The shade or shelter structure referred to in this by-law means the shade or shelter structure and associated supporting posts, brackets and restrainers utilized in the installation of the said shade or shelter structure.
- 1.4 A owner of a lot shall:
 - 1.4.1 Have a special privilege in respect of the common property to install and keep the shade or shelter structure in and on the common property, and a special privilege in respect to common property to supporting posts, brackets and restrainers on and through common property for the attachment and support of the structure or shelter and shall have the exclusive use of those parts of the common property occupied by the shade or shelter structure.
 - 1.4.2 Properly maintain and keep the common property in which the shade or shelter structure and associated supporting posts, brackets and restrainers is attached in a state of good and serviceable repair.
 - 1.4.3 Properly maintain and keep the shade or shelter structure and associated supporting posts, brackets and restrainers in a state of good and serviceable repair.
 - 1.4.4 Be responsible for any damage occasioned to the common property by the attachment on or through it by the shade or shelter structure and associated supporting posts, brackets and restrainers.
 - 1.4.5 Not be permitted to replace the shade or shelter structure without the approval of the Owners Corporation.
- 1.5 With respect to any shade or shelter structure installed prior to the making of this by-law:
 - 1.5.1 An owner shall inform the Owners Corporation in writing that such installation has been effected and such advice shall include details of the size of the structure and location on common property.
 - 1.5.2 The Owners Corporation may reasonably require the owner to ameliorate any adverse impact on the peaceful enjoyment of any owner or occupier of another lot or the appearance of the building.
 - 1.5.3 Owners hereby indemnify and keep indemnified the Owners Corporation in respect of that part of the common property benefiting the owners against all actions, proceedings, claims, demands, costs, damages and expenses which may be incurred by or brought or made against the Owners Corporation and arising directly or indirectly out of the use of the common property by the owners pursuant to this by-law.

ANNEXURE TO CONSOLIDATION/CHANGE OF BY-LAWS
CONDITIONS & PROVISIONS
THE OWNERS – STRATA PLAN NO 65573

Special By-Law No. 2 – By-law for Exclusive Use (Lot 3)ⁱⁱⁱ

1. Introduction

1.1 This is a common property rights by-law.

1.2 The purpose of this by-law is to grant the Owners the exclusive use of the Exclusive Use Area and to regulate the repair & maintenance obligations of the Owners in respect of the Exclusive Use Area on the terms and conditions of this by-law to which the Owners have consented in writing.

2. Definitions

2.1 Definitions

In this by-law:

- (a) **“Act”** means the *Strata Schemes Management Act, 1996* (NSW).
- (b) **“Building”** means the building(s) situated at 28-30 Third Avenue EPPING NSW 2121.
- (c) **“Claims”** means any and all claims, demands, causes of action (whether based in contract, equity, tort or statute and including loss or abatement of rent), suits, arbitration, mediation and all losses (including loss of income and other consequential losses), liabilities, costs, compensation, damages or expenses (including legal expenses) whatsoever arising out of or in any way connected with the Fencing which may be claimed against the Owners Corporation.
- (d) **“Exclusive Use Area”** is comprised of the entirety of the physical structure of the Fencing (excluding the air-space above the Fencing).
- (e) **“Fencing”** means the entirety of the common property treated pine timber paling fence servicing and enclosing the rear garden area of the Lot and abutting Grimes Lane as shown in the diagram below:

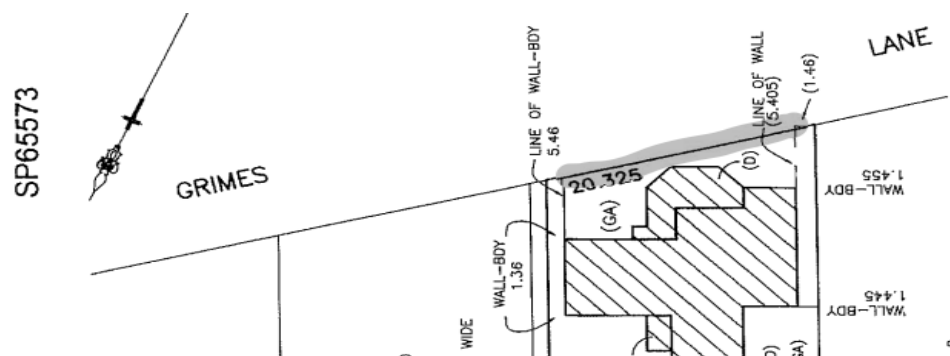

- (f) **“Lot”** means lot 3 the Strata Scheme.
- (g) **“Owners”** means the owner(s) of the Lot from time to time.
- (h) **“Owners Corporation”** means the owners corporation created on registration of the Strata Scheme.
- (i) **“Strata Scheme”** means the strata scheme created upon registration of strata plan number 65573.

2.2 Interpretation

In this by-law:

- (a) headings are for reference only;
- (b) the singular includes the plural and vice versa;
- (c) words denoting any gender include all genders;
- (d) where a word or phrase is defined its other grammatical forms have a corresponding meaning;

ANNEXURE TO CONSOLIDATION/CHANGE OF BY-LAWS
CONDITIONS & PROVISIONS
THE OWNERS – STRATA PLAN NO 65573

- (e) any reference to an Owner or the Owners Corporation in this by-law includes their successors and permitted assigns;
- (f) the use of the word includes or including is not to be taken as limiting the meaning of the words preceding it;
- (g) reference to any statute includes all regulations and amendments to that statute and any statute passed in substitution for that statute or incorporating any of its provisions to the extent that they are incorporated;
- (h) any terms in this by-law which are not defined will have the same meaning as those defined in Act or the *Strata Schemes (Freehold Development) Act, 1973* (NSW) respectively;
- (i) if any one or more of the provisions contained in this by-law shall be invalid, illegal or unenforceable in any respect, the validity, legality and enforceability of the remaining provisions of this by-law will not be affected or impaired thereby and the invalid, illegal or unenforceable provision(s) shall be deemed severed or modified to the extent which is necessary to make the remainder of the provisions of this by-law enforceable;
- (j) if there is any inconsistency between any by-laws applicable to the Strata Scheme and/or any notations on the strata plan and this by-law, the provisions of this by-law shall prevail to the extent of the inconsistency notwithstanding the intended effect of any such by-laws or notations;
- (k) any covenant, agreement or obligation imposed on the part of two or more persons shall bind them jointly and each of them severally; and
- (l) reference to Fencing and/or Exclusive Use Area includes, where relevant, any ancillary equipment, fittings and other componentry of the Fencing whatsoever including any finishes, foundations, supports, posts, and any obligation under this by-law in respect of the repair and maintenance obligations applies to such ancillary equipment, fittings and componentry etc.

3. Repair and maintenance of Fencing, indemnity

- 3.1 The Owners shall at their sole cost, expense and responsibility, repair, maintain (including arranging anti-termite treatment) and, if necessary, replace the Fencing and any affected common property, as and when required, from time to time, in the opinion of, or, as directed by, the Owners Corporation. Despite the foregoing, any future changes, alterations or movements to the Fencing may not be actioned until such time as such changes, alterations or movements are formally re-approved at a general meeting of the Owners Corporation via a new Special-By-law or amendment to this by-law, as this special by-law is for the existing Fencing, as it is and in its current condition, as at the date this special by-law is approved.
- 3.2 The Owners will make no objection, requisition or claim for compensation for or in connection with their obligations in respect of the Fencing and/or the Exclusive Use Area.
- 3.3 The Owners must, at their own cost:
 - 3.3.1 comply with any requirements of government agencies regarding the Fencing;
 - 3.3.2 repair damage to common property caused by complying or failing to comply with their obligations under this by-law;
 - 3.3.3 reimburse the Owners Corporation for any costs and expenses including any increased premium for its insurance policies caused by the Owners exercising their rights or performing their obligations under this by-law;
 - 3.3.4 indemnify the Owners Corporation from and against all Claims which may arise in respect of or in connection with the Fencing including its use or caused by failing to comply with their obligations under this by-law;
 - 3.3.5 give their written consent to the making of this by-law and to the repair and maintenance responsibilities imposed or conferred by this by-law in terms of the document attached at **Annexure "A"**; and
 - 3.3.6 pay all the costs of the Owners Corporation including:

ANNEXURE TO CONSOLIDATION/CHANGE OF BY-LAWS
CONDITIONS & PROVISIONS
THE OWNERS – STRATA PLAN NO 65573

- (i) professional fees required to properly consider and approve this by-law including legal and strata management and other experts' fees; and
- (ii) registration fees for the registration of this by-law including consolidation of by-law costs.

3.4 The Owners, when carrying out their repair and maintenance obligations under this by-law, shall:

- 3.4.1 ensure the works are carried out to "best practice" standards;
- 3.4.2 ensure the Fencing original materials of construction (eg treated pine) are utilised and that the dimensions and appearance of the original Fencing are preserved;
- 3.4.3 not alter the Fencing or its location without the prior written consent of the Owners Corporation;
- 3.4.4 ensure the Fencing remains in keeping with the appearance and amenity of the Building in the opinion of the Owners Corporation;
- 3.4.5 use duly licensed and insured employees, contractors and/or agents;
- 3.4.6 ensure compliance with the current Australian Building Codes and Standards and WH & S Law;
- 3.4.7 ensure they are conducted expeditiously with a minimum of disruption;
- 3.4.8 ensure they are conducted in a proper and workmanlike manner;
- 3.4.9 effect and maintain prudent insurances;
- 3.4.10 preserve the structural, fire and waterproofing integrity of the Building and provide certification of same if required by the Owners Corporation;
- 3.4.11 protect all affected areas of the Building from damage;
- 3.4.12 not store any items on or otherwise use any area of the common property except as may be permitted by this by-law or in writing by the Owners Corporation;
- 3.4.13 ensure that the Works are carried out between the hours of 8:00am and 4:00pm, Mondays – Fridays (public holidays excepted); and
- 3.4.14 be responsible for the Owners' employees, contractors and/or agents compliance with the requirements of this by-law.

3.5 The Owners Corporation specially resolved pursuant to Section 106 (3) of the Act to determine that:

- (a) it is inappropriate to maintain, renew, replace or repair the Fencing and/or the Exclusive Use Area; and
- (b) its decision will not affect the safety of any building, structure or common property in the Strata Scheme or detract from the appearance of any property in the Strata Scheme.

4. Owner's acknowledgement

The current Owners (Li Chen and Yidi Wan) on behalf of themselves and any future owner(s) of the Lot, acknowledge that the wire fence and gate, as shown in **Annexure "B"**, form part of the common property and that the owner(s) shall ensure that any future changes to the timber fence, do not disturb, damage, misalign etc. the common property wire gate and fence as shown in the photographs set out in **Annexure "B"**, a copy of which was tabled at the meeting at which this by-law was passed and may be attached to this by-law.

5. Applicability

For abundance of clarity, this by-law binds and enures to the benefit of any and all future Owners.

ANNEXURE TO CONSOLIDATION/CHANGE OF BY-LAWS

CONDITIONS & PROVISIONS

THE OWNERS – STRATA PLAN NO 65573

i BL16 Option A applies

ii SBL 1 registered dealing #AT697022 passed by the Owners Corporation on 27.10.2023

iii SBL 2 passed by the Owners Corporation on 28.08.2024



Signature: *Mallory Costen*

Name: Mallory Costen

Authority: Strata Managing Agent

Approved Form 23

Attestation

The seal of The Owners – Strata Plan No 65573 was affixed on 18th November 2024 in the presence of the following person(s) authorised by section 273 *Strata Schemes Management Act, 2015* (NSW) to attest the affixing of the seal.

Signature: 

Name: Mallory Costen

Authority: Strata Managing Agent

Executed at 12:13pm on 18.11.2024 by electronic signature affixed by me, Mallory Costen.



Signed and common seal affixed, by Mallory Costen on 18/11/2024 as Strata Managing Agent for SP 65573

Strata Schemes Management Regulation 1997

Repealed version for 1 July 2005 to 31 August 2005 (accessed 7 February 2019 at 15:23)

Schedule 1

Schedule 1 Model by-laws

(Clause 23)

Residential Schemes

1 Noise

An owner or occupier of a lot must not create any noise on a lot or the common property likely to interfere with the peaceful enjoyment of the owner or occupier of another lot or of any person lawfully using common property.

2 Vehicles

An owner or occupier of a lot must not park or stand any motor or other vehicle on common property except with the prior written approval of the owners corporation.

3 Obstruction of common property

An owner or occupier of a lot must not obstruct lawful use of common property by any person except on a temporary and non-recurring basis.

4 Damage to lawns and plants on common property

An owner or occupier of a lot must not, except with the prior written approval of the owners corporation:

- (a) damage any lawn, garden, tree, shrub, plant or flower being part of or situated on common property, or
- (b) use for his or her own purposes as a garden any portion of the common property.

5 Damage to common property

- (1) An owner or occupier of a lot must not mark, paint, drive nails or screws or the like into, or otherwise damage or deface, any structure that forms part of the common property except with the prior written approval of the owners corporation.
- (2) An approval given by the owners corporation under subclause (1) cannot authorise any additions to the common property.
- (3) This by-law does not prevent an owner or person authorised by an owner from installing:
 - (a) any locking or other safety device for protection of the owner's lot against intruders or to improve safety within the owner's lot, or
 - (b) any screen or other device to prevent entry of animals or insects on the lot, or
 - (c) any structure or device to prevent harm to children, or
 - (d) any device used to affix decorative items to the internal surfaces of walls in the owner's lot.

- (4) Any such locking or safety device, screen, other device or structure must be installed in a competent and proper manner and must have an appearance, after it has been installed, in keeping with the appearance of the rest of the building.
- (5) Despite section 62, the owner of a lot must:
 - (a) maintain and keep in a state of good and serviceable repair any installation or structure referred to in subclause (3) that forms part of the common property and that services the lot, and
 - (b) repair any damage caused to any part of the common property by the installation or removal of any locking or safety device, screen, other device or structure referred to in subclause (3) that forms part of the common property and that services the lot.

6 Behaviour of owners and occupiers

An owner or occupier of a lot when on common property must be adequately clothed and must not use language or behave in a manner likely to cause offence or embarrassment to the owner or occupier of another lot or to any person lawfully using common property.

7 Children playing on common property in building

An owner or occupier of a lot must not permit any child of whom the owner or occupier has control to play on common property within the building or, unless accompanied by an adult exercising effective control, to be or to remain on common property comprising a laundry, car parking area or other area of possible danger or hazard to children.

8 Behaviour of invitees

An owner or occupier of a lot must take all reasonable steps to ensure that invitees of the owner or occupier do not behave in a manner likely to interfere with the peaceful enjoyment of the owner or occupier of another lot or any person lawfully using common property.

9 Depositing rubbish and other material on common property

An owner or occupier of a lot must not deposit or throw on the common property any rubbish, dirt, dust or other material or discarded item except with the prior written approval of the owners corporation.

10 Drying of laundry items

An owner or occupier of a lot must not, except with the prior written approval of the owners corporation, hang any washing, towel, bedding, clothing or other article on any part of the parcel in such a way as to be visible from outside the building other than on any lines provided by the owners corporation for the purpose and there only for a reasonable period.

11 Cleaning windows and doors

An owner or occupier of a lot must keep clean all exterior surfaces of glass in windows and doors on the boundary of the lot, including so much as is common property, unless:

- (a) the owners corporation resolves that it will keep the glass or specified part of the glass clean, or
- (b) that glass or part of the glass cannot be accessed by the owner or occupier of the lot safely or at all.

12 Storage of inflammable liquids and other substances and materials

- (1) An owner or occupier of a lot must not, except with the prior written approval of the owners corporation, use or store on the lot or on the common property any inflammable chemical, liquid or gas or other inflammable material.
- (2) This by-law does not apply to chemicals, liquids, gases or other material used or intended to be used for domestic purposes, or any chemical, liquid, gas or other material in a fuel tank of a motor vehicle or internal combustion engine.

13 Moving furniture and other objects on or through common property

- (1) An owner or occupier of a lot must not transport any furniture or large object through or on common property within the building unless sufficient notice has first been given to the executive committee so as to enable the executive committee to arrange for its nominee to be present at the time when the owner or occupier does so.
- (2) An owners corporation may resolve that furniture or large objects are to be transported through or on the common property (whether in the building or not) in a specified manner.
- (3) If the owners corporation has specified, by resolution, the manner in which furniture or large objects are to be transported, an owner or occupier of a lot must not transport any furniture or large object through or on common property except in accordance with that resolution.

14 Floor coverings

- (1) An owner of a lot must ensure that all floor space within the lot is covered or otherwise treated to an extent sufficient to prevent the transmission from the floor space of noise likely to disturb the peaceful enjoyment of the owner or occupier of another lot.
- (2) This by-law does not apply to floor space comprising a kitchen, laundry, lavatory or bathroom.

15 Garbage disposal

- (1) An owner or occupier of a lot in a strata scheme that does not have shared receptacles for garbage, recyclable material or waste:
 - (a) must maintain such receptacles within the lot, or on such part of the common property as may be authorised by the owners corporation, in clean and dry condition and (except in the case of receptacles for recyclable material) adequately covered, and
 - (b) must ensure that before refuse, recyclable material or waste is placed in the receptacles it is, in the case of refuse, securely wrapped or, in the case of tins or other containers, completely drained, or, in the case of recyclable material or waste, separated and prepared in accordance with the applicable recycling guidelines, and
 - (c) for the purpose of having the garbage, recyclable material or waste collected, must place the receptacles within an area designated for that purpose by the owners corporation and at a time not more than 12 hours before the time at which garbage, recyclable material or waste is normally collected, and
 - (d) when the garbage, recyclable material or waste has been collected, must promptly return the receptacles to the lot or other area referred to in paragraph (a),
 - (e) must not place any thing in the receptacles of the owner or occupier of any other lot except with the permission of that owner or occupier, and
 - (f) must promptly remove any thing which the owner, occupier or garbage or recycling collector may have spilled from the receptacles and must take such action as may be necessary to

clean the area within which that thing was spilled.

- (2) An owner or occupier of a lot in a strata scheme that has shared receptacles for garbage, recyclable material or waste:
- (a) must ensure that before refuse, recyclable material or waste is placed in the receptacles it is, in the case of refuse, securely wrapped or, in the case of tins or other containers, completely drained, or, in the case of recyclable material or waste, separated and prepared in accordance with the applicable recycling guidelines, and
 - (b) must promptly remove any thing which the owner, occupier or garbage or recycling collector may have spilled in the area of the receptacles and must take such action as may be necessary to clean the area within which that thing was spilled.

16 Keeping of animals

Note. Select option A, B or C. If no option is selected, option A will apply.

Option A

(1)

Subject to section 49 (4), an owner or occupier of a lot must not, without the prior written approval of the owners corporation, keep any animal (except fish kept in a secure aquarium on the lot) on the lot or the common property.

(2)

The owners corporation must not unreasonably withhold its approval of the keeping of an animal on a lot or the common property.

Option B

(1)

Subject to section 49 (4), an owner or occupier of a lot must not, without the prior written approval of the owners corporation, keep any animal (except a cat, a small dog or a small caged bird, or fish kept in a secure aquarium on the lot) on the lot or the common property.

(2)

The owners corporation must not unreasonably withhold its approval of the keeping of an animal on a lot or the common property.

(3)

If an owner or occupier of a lot keeps a cat, small dog or small caged bird on the lot then the owner or occupier must:

- (a) notify the owners corporation that the animal is being kept on the lot, and
- (b) keep the animal within the lot, and
- (c) carry the animal when it is on the common property, and
- (d) take such action as may be necessary to clean all areas of the lot or the common property that are soiled by the animal.

Option C

Subject to section 49 (4), an owner or occupier of a residential lot must not keep any animal on the lot or the common property.

17 Appearance of lot

- (1) The owner or occupier of a lot must not, without the prior written approval of the owners corporation, maintain within the lot anything visible from outside the lot that, viewed from outside the lot, is not in keeping with the rest of the building.
- (2) This by-law does not apply to the hanging of any washing, towel, bedding, clothing or other article as referred to in by-law 10.

18 Change in use of lot to be notified

An occupier of a lot must notify the owners corporation if the occupier changes the existing use of the lot in a way that may affect the insurance premiums for the strata scheme (for example, if the change of use results in a hazardous activity being carried out on the lot, or results in the lot being used for commercial or industrial purposes rather than residential purposes).

19 Provision of amenities or services

- (1) The owners corporation may, by special resolution, determine to enter into arrangements for the provision of the following amenities or services to one or more of the lots, or to the owners or occupiers of one or more of the lots:
 - (a) window cleaning,
 - (b) garbage disposal and recycling services,
 - (c) electricity, water or gas supply,
 - (d) telecommunication services (for example, cable television).
- (2) If the owners corporation makes a resolution referred to in subclause (1) to provide an amenity or service to a lot or to the owner or occupier of a lot, it must indicate in the resolution the amount for which, or the conditions on which, it will provide the amenity or service.

Note. Section 111 of the Act provides that an owners corporation may enter into an agreement with an owner or occupier of a lot for the provision of amenities or services by it to the lot or to the owner or occupier.

Retirement Village Schemes

1 Noise

An owner or occupier of a lot must not create any noise on a lot or the common property likely to interfere with the peaceful enjoyment of the owner or occupier of another lot or of any person lawfully using common property.

2 Vehicles

An owner or occupier of a lot must not park or stand any motor or other vehicle on common property except with the prior written approval of the owners corporation.

3 Obstruction of common property

An owner or occupier of a lot must not obstruct lawful use of common property by any person except on a temporary and non-recurring basis.

4 Damage to lawns and plants on common property

An owner or occupier of a lot must not, except with the prior written approval of the owners corporation:

- (a) damage any lawn, garden, tree, shrub, plant or flower being part of or situated on common property, or

(b) use for his or her own purposes as a garden any portion of the common property.

5 Damage to common property

- (1) An owner or occupier of a lot must not mark, paint, drive nails or screws or the like into, or otherwise damage or deface, any structure that forms part of the common property except with the prior written approval of the owners corporation.
- (2) An approval given by the owners corporation under subclause (1) cannot authorise any additions to the common property.
- (3) This by-law does not prevent an owner or person authorised by an owner from installing:
 - (a) any locking or other safety device for protection of the owner's lot against intruders or to improve safety within the owner's lot, or
 - (b) any health or medical equipment that is necessary to preserve the health or well-being of the occupier of the lot, or
 - (c) any screen or other device to prevent entry of animals or insects on the lot, or
 - (d) any device used to affix decorative items to the internal surfaces of walls in the owner's lot.
- (4) Any such locking or safety device, equipment, screen or other device must be installed in a competent and proper manner and must have an appearance, after it has been installed, in keeping with the appearance of the rest of the building.
- (5) Despite section 62, the owner of a lot must:
 - (a) maintain and keep in a state of good and serviceable repair any installation referred to in subclause (3) that forms part of the common property and that services the lot, and
 - (b) repair any damage caused to any part of the common property by the installation or removal of any locking or safety device, equipment, screen or other device referred to in subclause (3) that forms part of the common property and that services the lot.

6 Behaviour of owners and occupiers

An owner or occupier of a lot when on common property must be adequately clothed and must not use language or behave in a manner likely to cause offence or embarrassment to the owner or occupier of another lot or to any person lawfully using common property.

7 Behaviour of invitees

An owner or occupier of a lot must take all reasonable steps to ensure that invitees of the owner or occupier do not behave in a manner likely to interfere with the peaceful enjoyment of the owner or occupier of another lot or any person lawfully using common property.

8 Depositing rubbish and other material on common property

An owner or occupier of a lot must not deposit or throw on the common property any rubbish, dirt, dust or other material or discarded item except with the prior written approval of the owners corporation.

9 Drying of laundry items

An owner or occupier of a lot must not, except with the prior written approval of the owners corporation, hang any washing, towel, bedding, clothing or other article on any part of the parcel in

such a way as to be visible from outside the building other than on any lines provided by the owners corporation for the purpose and there only for a reasonable period.

10 Cleaning windows and doors

An owner or occupier of a lot must keep clean all exterior surfaces of glass in windows and doors on the boundary of the lot, including so much as is common property, unless:

- (a) the owners corporation resolves that it will keep the glass or specified part of the glass clean, or
- (b) that glass or part of the glass cannot be accessed by the owner or occupier of the lot safely or at all.

11 Storage of inflammable liquids and other substances and materials

- (1) An owner or occupier of a lot must not, except with the prior written approval of the owners corporation, use or store on the lot or on the common property any inflammable chemical, liquid or gas or other inflammable material.
- (2) This by-law does not apply to chemicals, liquids, gases or other material used or intended to be used for domestic purposes, or any chemical, liquid, gas or other material in a fuel tank of a motor vehicle or internal combustion engine.

12 Moving furniture and other objects on or through common property

- (1) An owner or occupier of a lot must not transport any furniture or large object through or on common property within the building unless sufficient notice has first been given to the executive committee so as to enable the executive committee to arrange for its nominee to be present at the time when the owner or occupier does so.
- (2) An owners corporation may resolve that furniture or large objects are to be transported through or on the common property (whether in the building or not) in a specified manner.
- (3) If the owners corporation has specified, by resolution, the manner in which furniture or large objects are to be transported, then an owner or occupier of a lot must not transport any furniture or large object through or on common property except in accordance with that resolution.

13 Floor coverings

- (1) An owner of a lot must ensure that all floor space within the lot is covered or otherwise treated to an extent sufficient to prevent the transmission from the floor space of noise likely to disturb the peaceful enjoyment of the owner or occupier of another lot.
- (2) This by-law does not apply to floor space comprising a kitchen, laundry, lavatory or bathroom.

14 Garbage disposal

- (1) An owner or occupier of a lot in a strata scheme that does not have shared receptacles for garbage, recyclable material or waste:
 - (a) must maintain such receptacles within the lot, or on such part of the common property as may be authorised by the owners corporation, in clean and dry condition and (except in the case of receptacles for recyclable material) adequately covered, and
 - (b) must ensure that before refuse, recyclable material or waste is placed in the receptacles it is, in the case of refuse, securely wrapped or, in the case of tins or other containers, completely drained, or, in the case of recyclable material or waste, separated and prepared in accordance with the applicable recycling guidelines, and

- (c) for the purpose of having the garbage, recyclable material or waste collected, must place the receptacles within an area designated for that purpose by the owners corporation and at a time not more than 12 hours before the time at which garbage, recyclable material or waste is normally collected, and
 - (d) when the garbage, recyclable material or waste has been collected, must promptly return the receptacles to the lot or other area referred to in paragraph (a), and
 - (e) must not place any thing in the receptacles of the owner or occupier of any other lot except with the permission of that owner or occupier, and
 - (f) must promptly remove any thing which the owner, occupier or garbage or recycling collector may have spilled from the receptacles and must take such action as may be necessary to clean the area within which that thing was spilled.
- (2) An owner or occupier of a lot in a strata scheme that has shared receptacles for garbage, recyclable material or waste:
- (a) must ensure that before refuse, recyclable material or waste is placed in the receptacles it is, in the case of refuse, securely wrapped, or, in the case of tins or other containers, completely drained, or, in the case of recyclable material or waste, separated and prepared in accordance with the applicable recycling guidelines, and
 - (b) must promptly remove any thing which the owner, occupier or garbage or recycling collector may have spilled in the area of the receptacles and must take such action as may be necessary to clean the area within which that thing was spilled.

15 Keeping of animals

Note. Select option A, B or C. If no option is selected, option A will apply.

Option A

(1)

Subject to section 49 (4), an owner or occupier of a lot must not, without the prior written approval of the owners corporation, keep any animal (except fish kept in a secure aquarium on the lot) on the lot or the common property.

(2)

The owners corporation must not unreasonably withhold its approval of the keeping of an animal on a lot or the common property.

Option B

(1)

Subject to section 49 (4), an owner or occupier of a lot must not, without the prior written approval of the owners corporation, keep any animal (except a cat, a small dog, a small caged bird or except fish kept in a secure aquarium kept on the lot) on the lot or the common property.

(2)

The owners corporation must not unreasonably withhold its approval of the keeping of an animal on a lot or the common property.

(3)

If an owner or occupier of a lot keeps a cat, small dog or small caged bird on the lot then the owner or occupier must:

- (a) notify the owners corporation that the animal is being kept on the lot, and

- (b) keep the animal within the lot, and
- (c) carry the animal when it is on the common property, and
- (d) take such action as may be necessary to clean all areas of the lot or the common property that are soiled by the animal.

Option C

Subject to section 49 (4), the owner or occupier of a residential lot must not keep any animal on the lot or the common property.

16 Appearance of lot

- (1) The owner or occupier of a lot must not, without the prior written approval of the owners corporation, maintain within the lot anything visible from outside the lot that, viewed from outside the lot, is not in keeping with the rest of the building.
- (2) This by-law does not apply to the hanging of any washing, towel, bedding, clothing or other article as referred to in by-law 9.

17 Change in use of lot to be notified

An occupier of a lot must notify the owners corporation if the occupier changes the existing use of the lot in a way that may affect the insurance premiums for the strata scheme (for example, if the change of use results in a hazardous activity being carried out on the lot, or results in the lot being used for commercial or industrial purposes rather than residential purposes).

18 Provision of amenities or services

- (1) The owners corporation may, by special resolution, determine to enter into arrangements for the provision of the following amenities or services to one or more of the lots, or to the owners or occupiers of one or more of the lots:
 - (a) medical and nursing services,
 - (b) emergency response services,
 - (c) meals,
 - (d) domestic services,
 - (e) window cleaning,
 - (f) transportation,
 - (g) garbage disposal and recycling services,
 - (h) electricity, water or gas supply,
 - (i) telecommunication services (for example, cable television).
- (2) If the owners corporation makes a resolution referred to in subclause (1) to provide an amenity or service to a lot or to the owner or occupier of a lot, it must indicate in the resolution the amount for which, or the conditions on which, it will provide the amenity or service.

Note. Section 111 of the Act provides that an owners corporation may enter into an agreement with an owner or occupier of a lot for the provision of amenities or services by it to the lot or to the owner or occupier.

Industrial Schemes

1 Vehicles

- (1) An owner or occupier of a lot must not park or stand any motor or other vehicle on common property or permit any invitees of the owner or occupier to park or stand any motor or other vehicle on common property except with the prior written approval of the owners corporation.
- (2) The owners corporation must not unreasonably withhold its approval to the parking or standing of a motor vehicle on the common property.

2 Obstruction of common property

An owner or occupier of a lot must not obstruct lawful use of common property by any person except on a temporary and non-recurring basis.

3 Damage to common property

- (1) An owner or occupier of a lot must not mark, paint, drive nails or screws or the like into, or otherwise damage or deface, any structure that forms part of the common property except with the prior written approval of the owners corporation.
- (2) An approval given by the owners corporation under subclause (1) cannot authorise any additions to the common property.
- (3) This by-law does not prevent an owner or person authorised by an owner from installing:
 - (a) any locking or other safety device for protection of the owner's lot against intruders or to improve safety within the owner's lot, or
 - (b) any screen or other device to prevent entry of animals or insects on the lot, or
 - (c) any sign to advertise the activities of the occupier of the lot, or
 - (d) any device used to affix decorative items to the internal surfaces of walls in the owner's lot.
- (4) Any such locking or safety device, screen, other device or sign must be installed in a competent and proper manner and must have an appearance, after it has been installed, consistent with any guidelines established by the owners corporation about such installations or, in the absence of guidelines, in keeping with the appearance of the rest of the building.
- (5) Despite section 62, the owner of a lot must:
 - (a) maintain and keep in a state of good and serviceable repair any installation referred to in subclause (3) that forms part of the common property and that services the lot, and
 - (b) repair any damage caused to any part of the common property by the installation or removal of any locking or safety device, screen, other device or sign referred to in subclause (3) that forms part of the common property and that services the lot.

4 Children on common property

An owner or occupier of a lot must not permit any child of whom the owner or occupier has control to remain on common property, unless accompanied by an adult exercising effective control.

5 Behaviour of invitees

An owner or occupier of a lot must take all reasonable steps to ensure that invitees of the owner or occupier do not behave in a manner likely to interfere with the peaceful enjoyment of the owner or occupier of another lot or any person lawfully using common property.

6 Depositing rubbish and other material on common property

An owner or occupier of a lot must not deposit or throw on the common property any rubbish, dirt, dust or other material or discarded item except with the written approval of the owners corporation.

7 Cleaning windows and doors

An owner or occupier of a lot must keep clean all exterior surfaces of glass in windows and doors on the boundary of the lot, including so much as is common property, unless:

- (a) the owners corporation resolves that it will keep the glass or specified part of the glass clean, or
- (b) that glass or part of the glass cannot be accessed by the owner or occupier of the lot safely or at all.

8 Garbage disposal

- (1) An owner or occupier of a lot in a strata scheme that does not have shared receptacles for garbage, recyclable material or waste:
 - (a) must maintain such receptacles within the lot, or on such part of the common property as may be authorised by the owners corporation, in clean and dry condition and (except in the case of receptacles for recyclable material) adequately covered, and
 - (b) must ensure that before refuse, recyclable material or waste is placed in the receptacles it is, in the case of refuse, securely wrapped or, in the case of tins or other containers, completely drained, or, in the case of recyclable material or waste, separated and prepared in accordance with the applicable recycling guidelines, and
 - (c) for the purpose of having the garbage, recyclable material or waste collected, must place the receptacles within an area designated for that purpose by the owners corporation and at a time not more than 12 hours before the time at which garbage, recyclable material or waste is normally collected, and
 - (d) when the garbage, recyclable material or waste has been collected, must promptly return the receptacles to the lot or other area referred to in paragraph (a), and
 - (e) must not place any thing in the receptacles of the owner or occupier of any other lot except with the permission of that owner or occupier, and
 - (f) must promptly remove any thing which the owner, occupier or garbage or recycling collector may have spilled from the receptacles and must take such action as may be necessary to clean the area within which that thing was spilled.
- (2) Subclause (1) does not require an owner or occupier of a lot to dispose of any chemical, biological, toxic or other hazardous waste in a manner that would contravene any relevant law applying to the disposal of such waste.
- (3) An owner or occupier of a lot in a strata scheme that has shared receptacles for garbage, recyclable material or waste:
 - (a) must ensure that before refuse, recyclable material or waste is placed in the receptacles it is, in the case of refuse, securely wrapped or, in the case of tins or other containers, completely drained, or, in the case of recyclable material or waste, separated and prepared in accordance with the applicable recycling guidelines, and
 - (b) must promptly remove any thing which the owner, occupier or garbage or recycling collector may have spilled in the area of the receptacles and must take such action as may be

necessary to clean the area within which that thing was spilled.

- (4) Subclause (3) does not require an owner or occupier of a lot to dispose of any chemical, biological, toxic or other hazardous waste in a manner that would contravene any relevant law applying to the disposal of such waste.

9 Appearance of lot

The owner or occupier of a lot must not, without the prior written approval of the owners corporation, maintain within the lot anything visible from outside the lot that, viewed from outside the lot, is not in keeping with the rest of the building.

10 Change in use of lot to be notified

An occupier of a lot must notify the owners corporation if the occupier changes the existing use of the lot in a way that may affect the insurance premiums for the strata scheme (for example, if the change of use results in a hazardous activity being carried out on the lot).

11 Preservation of fire safety

The owner or occupier of a lot must not do any thing or permit any invitees of the owner or occupier to do any thing on the lot or common property that is likely to affect the operation of fire safety devices in the parcel or to reduce the level of fire safety in the lots or common property.

12 Prevention of hazards

The owner or occupier of a lot must not do any thing or permit any invitees of the owner or occupier to do any thing on the lot or common property that is likely to create a hazard or danger to the owner or occupier of another lot or any person lawfully using the common property.

13 Provision of amenities or services

- (1) The owners corporation may, by special resolution, determine to enter into arrangements for the provision of the following amenities or services to one or more of the lots, or to the owners or occupiers of one or more of the lots:

- (a) security services,
- (b) promotional services,
- (c) cleaning,
- (d) garbage disposal and recycling services,
- (e) electricity, water or gas supply,
- (f) telecommunication services (for example, cable television).

- (2) If the owners corporation makes a resolution referred to in subclause (1) to provide an amenity or service to a lot or to the owner or occupier of a lot, it must indicate in the resolution the amount for which, or the conditions on which, it will provide the amenity or service.

Note. Section 111 of the Act provides that an owners corporation may enter into an agreement with an owner or occupier of a lot for the provision of amenities or services by it to the lot or to the owner or occupier.

Hotel/Resort Schemes

1 Vehicles

- (1) An owner or occupier of a lot must not park or stand any motor or other vehicle on common property except with the prior written approval of the owners corporation.
- (2) The owners corporation must not unreasonably withhold its approval to the parking or standing of a motor vehicle on the common property.

2 Obstruction of common property

An owner or occupier of a lot must not obstruct lawful use of common property by any person except on a temporary and non-recurring basis.

3 Damage to common property

- (1) An owner or occupier of a lot must not mark, paint, drive nails or screws or the like into, or otherwise damage or deface, any structure that forms part of the common property without the prior written approval of the owners corporation.
- (2) An approval given by the owners corporation under subclause (1) cannot authorise any additions to the common property.
- (3) This by-law does not prevent an owner or person authorised by an owner from installing:
 - (a) any locking or other safety device for protection of the owner's lot against intruders or to improve safety within the owner's lot, or
 - (b) any screen or other device to prevent entry of animals or insects on the lot, or
 - (c) any structure or device to prevent harm to children, or
 - (d) any device used to affix decorative items to the internal surfaces of walls in the owner's lot.
- (4) Any such locking or safety device, screen, other device or structure must be installed in a competent and proper manner and must have an appearance, after it has been installed, consistent with any guidelines established by the owners corporation about such installations or, in the absence of guidelines, in keeping with the appearance of the rest of the building.
- (5) Despite section 62, the owner of a lot must:
 - (a) maintain and keep in a state of good and serviceable repair any installation or structure referred to in subclause (3) that forms part of the common property and that services the lot, and
 - (b) repair any damage caused to any part of the common property by the installation or removal of any locking or safety device, screen, other device or structure referred to in subclause (3) that forms part of the common property and that services the lot.

4 Behaviour of owners and occupiers

An owner or occupier of a lot when on common property must be adequately clothed and must not use language or behave in a manner likely to cause offence or embarrassment to the owner or occupier of another lot or to any person lawfully using common property.

5 Behaviour of invitees

An owner or occupier of a lot must take all reasonable steps to ensure that invitees of the owner or occupier do not behave in a manner likely to interfere with the peaceful enjoyment of the owner or occupier of another lot or any person lawfully using common property.

6 Depositing rubbish and other material on common property

An owner or occupier of a lot must not deposit or throw on the common property any rubbish, dirt, dust or other material or discarded item except with the prior written approval of the owners corporation.

7 Cleaning windows and doors

The owners corporation must keep clean all exterior surfaces of glass in windows and doors on the boundary of the lots, whether common property or part of a lot.

8 Storage of inflammable liquids and other substances and materials

- (1) An owner or occupier of a lot must not, except with the prior written approval of the owners corporation, use or store on the lot or on the common property any inflammable chemical, liquid or gas or other inflammable material.
- (2) This by-law does not apply to chemicals, liquids, gases or other material used or intended to be used for domestic purposes, or any chemical, liquid, gas or other material in a fuel tank of a motor vehicle or internal combustion engine.

9 Keeping of animals

Subject to section 49 (4), an owner or occupier of a lot must not keep any animal on the lot or the common property.

10 Appearance of lot

The owner or occupier of a lot must not, without the prior written approval of the owners corporation, maintain within the lot anything visible from outside the lot that, viewed from outside the lot, is not in keeping with the rest of the building.

11 Preservation of fire safety

The owner or occupier of a lot must not do any thing or permit any invitees of the owner or occupier to do any thing on the lot or common property that is likely to affect the operation of fire safety devices in the parcel or to reduce the level of fire safety in the lots or common property.

12 Provision of amenities or services

- (1) The owners corporation may, by special resolution, determine to enter into arrangements for the provision of the following amenities or services to one or more of the lots, or to the owners or occupiers of one or more of the lots:
 - (a) electricity, water or gas supply,
 - (b) telecommunication services (for example, cable television).
- (2) If the owners corporation makes a resolution referred to in subclause (1) to provide an amenity or service to a lot or to the owner or occupier of a lot, it must indicate in the resolution the amount for which, or the conditions on which, it will provide the amenity or service.

Note. Section 111 of the Act provides that an owners corporation may enter into an agreement with an owner or occupier of a lot for the provision of amenities or services by it to the lot or to the owner or occupier.

Commercial/Retail Schemes

1 Vehicles

- (1) An owner or occupier of a lot must not park or stand any motor or other vehicle on common property or permit any invitees of the owner or occupier to park or stand any motor or other

vehicle on common property except with the prior written approval of the owners corporation.

- (2) The owners corporation must not unreasonably withhold its approval to the parking or standing of a motor vehicle on the common property.

2 Obstruction of common property

An owner or occupier of a lot must not obstruct lawful use of common property by any person except on a temporary and non-recurring basis (for example a temporary display).

3 Damage to common property

- (1) An owner or occupier of a lot must not mark, paint, drive nails or screws or the like into, or otherwise damage or deface, any structure that forms part of the common property without the written approval of the owners corporation.
- (2) An approval given by the owners corporation under subclause (1) cannot authorise any additions to the common property.
- (3) This by-law does not prevent an owner or person authorised by an owner from installing:
 - (a) any locking or other safety device for protection of the owner's lot against intruders or to improve safety within the owner's lot, or
 - (b) any screen or other device to prevent entry of animals or insects on the lot, or
 - (c) any sign to advertise the activities of the occupier of the lot if the owners corporation has specified locations for such signs and that sign is installed in the specified locations, or
 - (d) any device used to affix decorative items to the internal surfaces of walls in the owner's lot.
- (4) Any such locking or safety device, screen, other device or sign must be installed in a competent and proper manner and must have an appearance, after it has been installed, consistent with any guidelines established by the owners corporation about such installations or, in the absence of guidelines, in keeping with the appearance of the rest of the building.
- (5) Despite section 62, the owner of a lot must:
 - (a) maintain and keep in a state of good and serviceable repair any installation referred to in subclause (3) that forms part of the common property and that services the lot, and
 - (b) repair any damage caused to any part of the common property by the installation or removal of any locking or safety device, screen, other device or sign referred to in subclause (3) that forms part of the common property and that services the lot.

4 Behaviour of invitees

An owner or occupier of a lot must take all reasonable steps to ensure that invitees of the owner or occupier (including all customers and staff) do not behave in a manner likely to interfere with the peaceful enjoyment of the owner or occupier of another lot or any person lawfully using common property.

5 Depositing rubbish and other material on common property

An owner or occupier of a lot must not deposit or throw on the common property any rubbish, dirt, dust or other material or discarded item except with the prior written approval of the owners corporation.

6 Cleaning windows and doors

The owners corporation must keep clean all exterior surfaces of glass in windows and doors on the boundary of the lots, whether a part of a lot or common property.

7 Garbage disposal

- (1) An owner or occupier of a lot in a strata scheme that does not have shared receptacles for garbage, recyclable material or waste:
 - (a) must maintain such receptacles within the lot, or on such part of the common property as may be authorised by the owners corporation, in clean and dry condition and (except in the case of receptacles for recyclable material) adequately covered, and
 - (b) must ensure that before refuse, recyclable material or waste is placed in the receptacles it is, in the case of refuse, securely wrapped or, in the case of tins or other containers, completely drained, or, in the case of recyclable material or waste, separated and prepared in accordance with the applicable recycling guidelines, and
 - (c) for the purpose of having the garbage, recyclable material or waste collected, must place the receptacles within an area designated for that purpose by the owners corporation and at a time not more than 12 hours before the time at which garbage, recyclable material or waste is normally collected, and
 - (d) when the garbage, recyclable material or waste has been collected, must promptly return the receptacles to the lot or other area referred to in paragraph (a), and
 - (e) must not place any thing in the receptacles of the owner or occupier of any other lot except with the permission of that owner or occupier, and
 - (f) must promptly remove any thing which the owner, occupier or garbage or recycling collector may have spilled from the receptacles and must take such action as may be necessary to clean the area within which that thing was spilled.
- (2) Subclause (1) does not require an owner or occupier of a lot to dispose of any chemical, biological, toxic or other hazardous waste in a manner that would contravene any relevant law applying to the disposal of such waste.
- (3) An owner or occupier of a lot in a strata scheme that has shared receptacles for garbage, recyclable material or waste:
 - (a) must ensure that before refuse, recyclable material or waste is placed in the receptacles it is, in the case of refuse, securely wrapped or, in the case of tins or other containers, completely drained, or, in the case of recyclable material or waste, separated and prepared in accordance with the applicable recycling guidelines, and
 - (b) must promptly remove any thing which the owner, occupier or garbage or recycling collector may have spilled in the area of the receptacles and must take such action as may be necessary to clean the area within which that thing was spilled.
- (4) Subclause (3) does not require an owner or occupier of a lot to dispose of any chemical, biological, toxic or other hazardous waste in a manner that would contravene any relevant law applying to the disposal of such waste.

8 Appearance of lot

The owner or occupier of a lot must not, without the prior written approval of the owners corporation, maintain within the lot anything visible from outside the lot that, viewed from outside the lot, is not in keeping with the rest of the building.

9 Change in use of lot to be notified

An occupier of a lot must notify the owners corporation if the occupier changes the existing use of the lot in a way that may affect the insurance premiums for the strata scheme (for example, if the change of use results in a hazardous activity being carried out on the lot).

10 Preservation of fire safety

The owner or occupier of a lot must not do any thing or permit any invitees of the owner or occupier to do any thing on the lot or common property that is likely to affect the operation of fire safety devices in the parcel or to reduce the level of fire safety in the lots or common property.

11 Prevention of hazards

The owner or occupier of a lot must not do any thing or permit any invitees of the owner or occupier to do any thing on the lot or common property that is likely to create a hazard or danger to the owner or occupier of another lot or any person lawfully using the common property.

12 Provision of amenities or services

(1) The owners corporation may, by special resolution, determine to enter into arrangements for the provision of the following amenities or services to one or more of the lots, or to the owners or occupiers of one or more of the lots:

- (a) security services,
- (b) promotional services,
- (c) advertising,
- (d) cleaning,
- (e) garbage disposal and recycling services,
- (f) electricity, water or gas supply,
- (g) telecommunication services (for example, cable television).

(2) If the owners corporation makes a resolution referred to in subclause (1) to provide an amenity or service to a lot or to the owner or occupier of a lot, it must indicate in the resolution the amount for which, or the conditions on which, it will provide the amenity or service.

Note. Section 111 of the Act provides that an owners corporation may enter into an agreement with an owner or occupier of a lot for the provision of amenities or services by it to the lot or to the owner or occupier.

13 Controls on hours of operation and use of facilities

(1) The owners corporation may, by special resolution, make any of the following determinations if it considers the determination is appropriate for the control, management, administration, use or enjoyment of the lots or the lots and common property of the strata scheme:

- (a) that commercial or business activities may be conducted on a lot or common property only during certain times,
- (b) that facilities situated on the common property may be used only during certain times or on certain conditions.

(2) An owner or occupier of a lot must comply with a determination referred to in subclause (1).

Mixed Use Schemes

1 Noise

An owner or occupier of a lot must not create any noise on a lot or the property likely to interfere with the peaceful enjoyment of the owner or occupier of another lot or of any person lawfully using common property.

2 Vehicles

- (1) An owner or occupier of a lot must not park or stand any motor or other vehicle on common property or permit any invitees of the owner or occupier to park or stand any motor or other vehicle on common property except with the prior written approval of the owners corporation.
- (2) The owners corporation must not unreasonably withhold its approval to the parking or standing of a motor vehicle on the common property.

3 Obstruction of common property

An owner or occupier of a lot must not obstruct lawful use of common property by any person except on a temporary and non-recurring basis.

4 Damage to lawns and plants on common property

An owner or occupier of a lot must not, except with the prior written approval of the owners corporation:

- (a) damage any lawn, garden, tree, shrub, plant or flower being part of or situated on common property, or
- (b) use for his or her own purposes as a garden any portion of the common property.

5 Damage to common property

- (1) An owner or occupier of a lot must not mark, paint, drive nails or screws or the like into, or otherwise damage or deface, any structure that forms part of the common property except with the written approval of the owners corporation.
- (2) An approval given by the owners corporation under subclause (1) cannot authorise any additions to the common property.
- (3) This by-law does not prevent an owner or person authorised by an owner from installing:
 - (a) any locking or other safety device for protection of the owner's lot against intruders or to improve safety within the owner's lot, or
 - (b) any screen or other device to prevent entry of animals or insects on the lot, or
 - (c) any structure or device to prevent harm to children, or
 - (d) any sign to advertise the activities of the occupier of the lot if the owners corporation has specified locations for such signs and that sign is installed in the specified locations, or
 - (e) any device used to affix decorative items to the internal surfaces of walls in the owner's lot.
- (4) Any such locking or safety device, screen, other device or structure must be installed in a competent and proper manner and must have an appearance, after it has been installed, in keeping with the appearance of the rest of the building.
- (5) Despite section 62, the owner of a lot must:

- (a) maintain and keep in a state of good and serviceable repair any installation or structure referred to in subclause (3) that forms part of the common property and that services the lot, and
- (b) repair any damage caused to any part of the common property by the installation or removal of any locking or safety device, screen, other device or structure referred to in subclause (3) that forms part of the common property and that services the lot.

6 Behaviour of owners and occupiers

An owner or occupier of a lot when on common property must be adequately clothed and must not use language or behave in a manner likely to cause offence or embarrassment to the owner or occupier of another lot or to any person lawfully using common property.

7 Children playing on common property in building

An owner or occupier of a lot must not permit any child of whom the owner or occupier has control to play on common property within the building or, unless accompanied by an adult exercising effective control, to be or to remain on common property comprising a laundry, car parking area or other area of possible danger or hazard to children.

8 Behaviour of invitees

An owner or occupier of a lot must take all reasonable steps to ensure that invitees of the owner or occupier do not behave in a manner likely to interfere with the peaceful enjoyment of the owner or occupier of another lot or any person lawfully using common property.

9 Depositing rubbish and other material on common property

An owner or occupier of a lot must not deposit or throw on the common property any rubbish, dirt, dust or other material or discarded item except with the prior written approval of the owners corporation.

10 Drying of laundry items

An owner or occupier of a lot must not, except with the prior written approval of the owners corporation, hang any washing, towel, bedding, clothing or other article on any part of the parcel in such a way as to be visible from outside the building other than on any lines provided by the owners corporation for the purpose and there only for a reasonable period.

11 Cleaning windows and doors

An owner or occupier of a lot must keep clean all exterior surfaces of glass in windows and doors on the boundary of the lot, including so much as is common property, unless:

- (a) the owners corporation resolves that it will keep the glass or specified part of the glass clean, or
- (b) that glass or part of the glass cannot be accessed by the owner or occupier of the lot safely or at all.

12 Storage of inflammable liquids and other substances and materials

- (1) An owner or occupier of a lot must not, except with the prior written approval of the owners corporation, use or store on the lot or on the common property any inflammable chemical, liquid or gas or other inflammable material.
- (2) This by-law does not apply to chemicals, liquids, gases or other material used or intended to be used for domestic purposes, or any chemical, liquid, gas or other material in a fuel tank of a

motor vehicle or internal combustion engine.

13 Moving furniture and other objects on or through common property

- (1) An owner or occupier of a lot must not transport any furniture, large object or deliveries to or from the lot through or on common property within the building unless sufficient notice has first been given to the executive committee so as to enable the executive committee to arrange for its nominee to be present at the time when the owner or occupier does so.
- (2) An owners corporation may resolve that furniture, large objects or deliveries to and from the lot are to be transported through or on the common property (whether in the building or not) in a specified manner.
- (3) If the owners corporation has specified, by resolution, the manner in which furniture, large objects or deliveries to and from the lot are to be transported, then an owner or occupier of a lot must not transport any furniture, large object or deliveries to and from the lot through or on common property except in accordance with that resolution.

14 Floor coverings

- (1) An owner of a lot must ensure that all floor space within the lot is covered or otherwise treated to an extent sufficient to prevent the transmission from the floor space of noise likely to disturb the peaceful enjoyment of the owner or occupier of another lot.
- (2) This by-law does not apply to floor space comprising a kitchen, laundry, lavatory or bathroom.

15 Garbage disposal

- (1) An owner or occupier of a lot in a strata scheme that does not have shared receptacles for garbage, recyclable material or waste:
 - (a) must maintain such receptacles within the lot, or on such part of the common property as may be authorised by the owners corporation, in clean and dry condition and (except in the case of receptacles for recyclable material) adequately covered, and
 - (b) must ensure that before refuse, recyclable material or waste is placed in the receptacles it is, in the case of refuse, securely wrapped or, in the case of tins or other containers, completely drained, or, in the case of recyclable material or waste, separated and prepared in accordance with the applicable recycling guidelines, and
 - (c) for the purpose of having the garbage, recyclable material or waste collected, must place the receptacles within an area designated for that purpose by the owners corporation and at a time not more than 12 hours before the time at which garbage, recyclable material or waste is normally collected, and
 - (d) when the garbage, recyclable material or waste has been collected, must promptly return the receptacles to the lot or other area referred to in paragraph (a),
 - (e) must not place any thing in the receptacles of the owner or occupier of any other lot except with the permission of that owner or occupier, and
 - (f) must promptly remove any thing which the owner, occupier or garbage or recycling collector may have spilled from the receptacles and must take such action as may be necessary to clean the area within which that thing was spilled.
- (2) Subclause (1) does not require an owner or occupier of a lot to dispose of any chemical, biological, toxic or other hazardous waste in a manner that would contravene any relevant law

applying to the disposal of such waste.

- (3) An owner or occupier of a lot in a strata scheme that has shared receptacles for garbage, recyclable material or waste:
- (a) must ensure that before refuse, recyclable material or waste is placed in the receptacles it is, in the case of refuse, securely wrapped or, in the case of tins or other containers, completely drained, or, in the case of recyclable material or waste, separated and prepared in accordance with the applicable recycling guidelines, and
 - (b) must promptly remove any thing which the owner, occupier or garbage or recycling collector may have spilled in the area of the receptacles and must take such action as may be necessary to clean the area within which that thing was spilled.
- (4) Subclause (3) does not require an owner or occupier of a lot to dispose of any chemical, biological, toxic or other hazardous waste in a manner that would contravene any relevant law applying to the disposal of such waste.

16 Keeping of animals

Note. Select option A, B or C. If no option is selected, option A will apply.

Option A

(1)

Subject to section 49 (4), an owner or occupier of a residential lot must not, without the prior written approval of the owners corporation, keep any animal (except fish kept in a secure aquarium on the lot) on the lot or the common property.

(2)

The owners corporation must not unreasonably withhold its approval of the keeping of an animal on a residential lot or the common property.

Option B

(1)

Subject to section 49 (4), an owner or occupier of a residential lot must not, without the prior written approval of the owners corporation, keep any animal (except a cat, a small dog or a small caged bird, or fish kept in a secure aquarium on the lot) on the lot or the common property.

(2)

The owners corporation must not unreasonably withhold its approval of the keeping of an animal on a residential lot or the common property.

(3)

If an owner or occupier of a residential lot keeps a cat, small dog or small caged bird on the lot then the owner or occupier must:

- (a) notify the owners corporation that the animal is being kept on the lot, and
- (b) keep the animal within the lot, and
- (c) carry the animal when it is on the common property, and
- (d) take such action as may be necessary to clean all areas of the lot or the common property that are soiled by the animal.

Option C

Subject to section 49 (4), an owner or occupier of a residential lot must not keep any animal on the lot or the common property.

17 Appearance of lot

- (1) The owner or occupier of a lot must not, except with the prior written approval of the owners corporation, maintain within the lot anything visible from outside the lot that, viewed from outside the lot, is not in keeping with the rest of the building.
- (2) This by-law does not apply to the hanging of any washing, towel, bedding, clothing or other article as referred to in by-law 10.

18 Change in use of lot to be notified

An occupier of a lot must notify the owners corporation if the occupier changes the existing use of the lot in a way that may affect the insurance premiums for the strata scheme (for example, if the change of use results in a hazardous activity being carried out on the lot, or results in the lot being used for commercial or industrial purposes rather than residential purposes).

19 Preservation of fire safety

The owner or occupier of a lot must not do any thing or permit any invitees of the owner or occupier to do any thing on the lot or common property that is likely to affect the operation of fire safety devices in the parcel or to reduce the level of fire safety in the lots or common property.

20 Prevention of hazards

The owner or occupier of a lot must not do any thing or permit any invitees of the owner or occupier to do any thing on the lot or common property that is likely to create a hazard or danger to the owner or occupier of another lot or any person lawfully using the common property.

21 Provision of amenities or services

- (1) The owners corporation may, by special resolution, determine to enter into arrangements for the provision of the following amenities or services to one or more of the lots, or to the owners or occupiers of one or more of the lots:
 - (a) security services,
 - (b) promotional services,
 - (c) advertising,
 - (d) commercial cleaning,
 - (e) domestic services,
 - (f) garbage disposal and recycling services,
 - (g) electricity, water or gas supply,
 - (h) telecommunication services (for example, cable television).
- (2) If the owners corporation makes a resolution referred to in subclause (1) to provide an amenity or service to a lot or to the owner or occupier of a lot, it must indicate in the resolution the amount for which, or the conditions on which, it will provide the amenity or service.

Note. Section 111 of the Act provides that an owners corporation may enter into an agreement with an owner or occupier of a lot for the provision of amenities or services by it to the lot or to the owner or occupier.

22 Controls on hours of operation and use of facilities

- (1) The owners corporation may, by special resolution, make any of the following determinations if it considers the determination is appropriate for the control, management, administration, use or enjoyment of the lots or the lots and common property of the strata scheme:
 - (a) that commercial or business activities may be conducted on a lot or common property only during certain times,
 - (b) that facilities situated on the common property may be used only during certain times or on certain conditions.
- (2) An owner or occupier of a lot must comply with a determination referred to in subclause (1).

PLANNING CERTIFICATE

CERTIFICATE UNDER SECTION 10.7

Environmental Planning and Assessment Act, 1979 as amended

**Hills Conveyancing
DX 18504
CASTLE HILL**

Certificate No: 2026/2300
Fee: \$70.62
Issue Date: 20 March 2026
Receipt No: 8350818
Applicant Ref: CAPP:268112

DESCRIPTION OF LAND

Address: 2/30 Third Avenue
EPPING NSW 2121

Lot Details: Lot 2 SP 65573

SECTION A

The following Environmental Planning Instrument to which this certificate relates applies to the land:

Parramatta Local Environmental Plan 2023

For the purpose of **Section 10.7(2)** it is advised that as the date of this certificate the abovementioned land is affected by the matters referred to as follows:

The land is zoned: R2 Low Density Residential PLEP2023**Zone R2 Low Density Residential (Parramatta Local Environmental Plan 2023)**

Issued pursuant to Section 10.7 of the Environmental Planning and Assessment Act, 1979. NOTE: This table is an excerpt from Parramatta Local Environmental Plan 2023 and must be read in conjunction with and subject to the other provisions of that instrument, and in force at that date.

Zone R2 Low Density Residential**1 Objectives of zone**

- To provide for the housing needs of the community within a low density residential environment.
- To enable other land uses that provide facilities or services to meet the day to day needs of residents.
- To maintain the low density residential character of the area.
- To ensure non-residential land uses are carried out in a way that minimises impacts on the amenity of a low density residential environment.
- To provide a range of community facilities that serve the needs of people who live in, work in and visit the area.
- To protect and enhance tree canopy, existing vegetation and other natural features

2 Permitted without consent

Home occupations

3 Permitted with consent

Bed and breakfast accommodation; Building identification signs; Business identification signs; Centre-based child care facilities; Community facilities; Dual occupancies; Dwelling houses; Educational establishments; Emergency services facilities; Environmental protection works; Exhibition homes; Exhibition villages; Flood mitigation works; Group homes; Home-based child care; Home businesses; Home industries; Hostels; Neighbourhood shops; Oyster aquaculture; Pond-based aquaculture; Public administration buildings; Recreation areas; Recreation facilities (outdoor); Respite day care centres; Roads; School-based child care; Seniors housing; Tank-based aquaculture; Water recycling facilities

4 Prohibited

Any development not specified in item 2 or 3

SECTION B**State Policies and Regional Environmental Plans**

The land is also affected by the following State Environmental Planning Policies (SEPP) and Regional Environmental Plans (SREP):

State Environmental Planning Policy (SEPP) (Biodiversity and Conservation) 2021
State Environmental Planning Policy (SEPP) (Planning Systems) 2021
State Environmental Planning Policy (SEPP) (Resilience and Hazards) 2021
State Environmental Planning Policy (SEPP) (Transport and Infrastructure) 2021

State Environmental Planning Policy (SEPP) (Precincts—Central River City) 2021
State Environmental Planning Policy (SEPP) (Housing) 2021
State Environmental Planning Policy (SEPP) (Resources and Energy) 2021
State Environmental Planning Policy (SEPP) (Primary Production) 2021
State Environmental Planning Policy (SEPP) (Sustainable Buildings) 2022
State Environmental Planning Policy (SEPP) No.65 – Design Quality of Residential Flat Development.
State Environmental Planning Policy (SEPP) (Exempt and Complying Development Codes) 2008

N.B. All enquiries as to the application of Draft State Environmental Planning Policies should be directed to The NSW Department of Planning, Housing and Infrastructure.

Draft Local Environmental Plan

The land is affected by a Draft Local Environmental Plan which is or has been subject to community consultation or public exhibition under the Act, that will apply to the carrying out of development on the land. The Draft Local Environmental Plan is described below.

Harmonisation Supplementary Matters and Housekeeping Planning Proposal

This land is affected by the planning proposal seeking to amend the Parramatta Local Environmental Plan (LEP) 2023. The Planning Proposal contains several administrative amendments known as ‘housekeeping matters’ to the planning controls in the Parramatta Local Environmental Plan (LEP) 2023.

The planning proposal seeks to:

- Rezone some land in the Parramatta Local Environmental Plan (LEP) 2023.
- Remove Clause 6.19 *Subdivisions for dual occupancies prohibited on certain land* from the Parramatta Local Environmental Plan (LEP) 2023. Amend the dual occupancy prohibition map in the Parramatta Local Environmental Plan (LEP) 2023 to remove properties marked with an ‘S’.
- Remove the intensive Urban Development Area Map from the Parramatta Local Environmental Plan (LEP) 2023.
- Amend Clause 3.3(2) and 6.3(2) of the Parramatta Local Environmental Plan (LEP) 2023 to correct references to the Biodiversity Map.
- Amend Clause 5.1(2) and the Land Reservation Acquisition Map of the Parramatta Local Environmental Plan (LEP) 2023:
 - Removing “Local Road” Infrastructure and “Council” as the relevant acquisition authority as there is no associated mapping and it is not required.
 - Removing “School” Infrastructure and “Department of Education” as the relevant acquisition authority as they are not standard map labels and amending them to the standard “Educational Establishment / “Department of Education” label.
- Amend Clause 5.1A(3) of the Parramatta Local Environmental Plan (LEP) 2023 to include “Regional cycleway”.
- Amend Clauses 6.12, 7.10 and 8.4 of the Parramatta Local Environmental Plan (LEP) 2023 to clarify “active uses”.
- Amend Clauses 6.20(1) and (2) of the Parramatta Local Environmental Plan (LEP) 2023 to omit references to mapping colour.

- Amend Clause 6.21(1) and (3) of the Parramatta Local Environmental Plan (LEP) 2023 to omit references to mapping colour;
- Amend Clause 7.17(2) of the Parramatta Local Environmental Plan (LEP) 2023 to omit reference to buildings with a GFA <2,000m².
- Amend Clause 7.25(4)(c)(i) to (ii) in the Parramatta Local Environmental Plan (LEP) 2023 to clarify 'room' in the context of hotel, motel, and serviced apartments.
- Amend Schedule 2 Exempt Development in the Parramatta Local Environmental Plan (LEP) 2023 to introduce advertising signage for public sportsgrounds for land zoned zone RE1 Public Recreation Parramatta Local Environmental Plan (LEP) 2023.
- Amend the title of Clause 4.1C of the Parramatta Local Environmental Plan (LEP) 2023 to remove the word subdivision.
- Correct other anomalies, omissions, and inconsistencies in the Parramatta Local Environmental Plan (LEP) 2023 and Parramatta Local Environmental Plan (LEP) 2023 Maps.

Further information on the Planning Proposal to amend Parramatta Local Environmental Plan (LEP) 2023 can be found at <https://participate.cityofparramatta.nsw.gov.au> or by contacting Council.

Development Control Plan

The land is affected by the Parramatta Development Control Plan (DCP) 2023

Development Contribution Plan

The subject land is within the Greater Sydney region to which the Environmental Planning and Assessment (Housing and Productivity Contribution) Order 2023 applies.

The City of Parramatta (Outside CBD) Development Contributions Plan 2021 Amendment 1 applies to the land.

Heritage Item/Heritage Conservation Area

An item of environmental heritage is not situated on the land.

The land is not located in a heritage conservation area.

Road Widening

The land is not affected by road widening or road realignment under:

- (a) Division 2 of Part 3 of the Roads Act 1993.
- (b) Any Environmental Planning Instrument.
- (c) Any Resolution of Council.

Land Reservation Acquisition

The land is not affected by Land Reservation Acquisition in Parramatta Local Environmental Plan 2023.

Site Compatibility Certificate (Affordable Rental Housing)

At the date of issue of this certificate Council is not aware of any

a. Site compatibility certificate (affordable rental housing),
in respect to the land.

Contamination

Matters contained in Clause 59(2) as amended in the Contaminated Land Management Act 1997 – as listed:

Clause 59(2)(a) - is the land to which the certificate relates is significantly contaminated land?

NO

Clause 59(2)(b) - is the land to which the certificate relates is subject to a management order?

NO

Clause 59(2)(c) - is the land to which the certificate relates is the subject of an approved voluntary management proposal?

NO

Clause 59(2)(d) - is the land to which the certificate relates is subject to an ongoing maintenance order?

NO

Clause 59(2)(e) - is the land to which the certificate relates is the subject of a site audit statement?

NO

Tree Preservation

The land is subject to Section 5.3.4 Trees and Vegetation Preservation in the Parramatta Development Control Plan (DCP) 2023.

Council has not been notified of an order under the Trees (Disputes Between Neighbours) Act 2006 to carry out work in relation to a tree on the land.

Coastal Protection

Has the owner (or any previous owner) of the land been consented in writing to the land being subject to annual charges under section 496B of the Local Government Act 1993 for coastal protection services that relate to existing coastal protection works (within the meaning of section 553B of that Act)?

NO

Council Policy

Council has not adopted a policy to restrict the development of the land by reason of the likelihood of projected sea level rise (coastal protection), tidal inundation, subsidence or any other risk.

Council has adopted a policy covering the entire City of Parramatta to restrict development of any land by reason of the likelihood of flooding.

Council has adopted by resolution a policy on contaminated land that applies to all land within the City of Parramatta. The Policy will restrict the development of the land if the circumstances set out in the policy prevail. A copy of the policy is available on Council's website at www.cityofparramatta.nsw.gov.au or from the Customer Service Centre.

NSW Rural Fire Service Guidelines entitled 'Planning for Bushfire Protection 2019' applies to land within the City of Parramatta. Development subject to bushfire risk will be required to address the requirements in these guidelines and can be downloaded off the RFS web site www.rfs.nsw.gov.au

Please note: this is a statement of Council policy and not a statement on whether or not the property is affected by bushfire. That question is answered in the Bushfire Land section of this certificate.

Mine Subsidence

The land is not affected by the Coal Mine Subsidence Compensation Act 2017 proclaiming land to be a Mine Subsidence District.

Bushfire Land

The land is not bushfire prone land.

Threatened Species

NSW Office of Environment and Heritage mapping indicates this site may contain 'native vegetation' or is included on the 'Biodiversity Values Map' which are subject to Part 7 of the Biodiversity Conservation Act 2016.

Biodiversity certified land

The land is not biodiversity certified land under Part 8 of the Biodiversity Conservation Act 2016.

Note. *Biodiversity certified land includes land certified under Part 7AA of the Threatened Species Conservation Act 1995 that is taken to be certified under Part 8 of the Biodiversity Conservation Act 2016.*

Biodiversity stewardship sites

The Chief Executive of the Office of Environment and Heritage has not notified the Council if the land is a biodiversity stewardship site under a biodiversity stewardship agreement under Part 5 of the Biodiversity Conservation Act 2016.

Note: Biodiversity stewardship agreements include biobanking agreements under Part 7A of the Threatened Species Conservation Act 1995 that are taken to be biodiversity stewardship agreements under Part 5 of the Biodiversity Conservation Act 2016.

Property vegetation plans

Council has not been notified of the existence of the property vegetation plan approved under Part 4 of the Native Vegetation Act 2003 on the land.

Paper Subdivision information

The land is not subject to any development plan adopted by a relevant authority or that is proposed to be subject to a consent ballot. A subdivision order does not apply to the land.

Note: Words and expressions used in this section have the same meaning as in the Environmental Planning and Assessment Regulation 2021, Part 10 and the Environmental Planning and Assessment Act 1979, Schedule 7.

Western Sydney Aerotropolis

Under State Environmental Planning Policy (Precincts—Western Parkland City) 2021, Chapter 4 the land:

- (a) is not in an ANEF or ANEC contour of 20 or greater, as referred to in that Chapter, section 4.17,
- (b) is not shown on the Lighting Intensity and Wind Shear Map,
- (c) is not shown on the Obstacle Limitation Surface Map,
- (d) is not in the “public safety area” on the Public Safety Area Map,
- (e) is not in the “3 kilometre wildlife buffer zone” or the “13 kilometre wildlife buffer zone” on the Wildlife Buffer Zone Map.

Loose-Fill Asbestos Register

Council has not been notified by NSW Fair Trading of the property being listed on the loose-fill asbestos insulation register maintained by the Secretary of NSW Fair Trading.

Affected Building Notices and Building Product Rectification Orders

Council is not aware of whether there is any affected building notice, building product rectification order or notice of intention to make a building product rectification order that is in force in respect of the land.

Note: *affected building notice* has the same meaning as in the *Building Products (Safety) Act 2017*. *building product rectification order* has the same meaning as in the *Building Products (Safety) Act 2017*.

State Environmental Planning Policy (Exempt and Complying Development Codes) 2008

Exempt Development Codes

Clause 1.12 State Environmental Planning Policy (Exempt and Complying Development Codes) 2008

The land **is not** land where the exempt development codes are varied under Clause 1.12 of State Environmental Planning Policy (Exempt and Complying Development Codes) 2008

Clauses 1.16(1)(b1)–(d) or Clause 1.16A of State Environmental Planning Policy (Exempt and Complying Development Codes)

The following information only addresses whether or not the land is land on which exempt development may be carried out under each of the codes for exempt development because of the provisions of **Clauses 1.16(1)(b1)–(d) or Clause 1.16A** of State Environmental Planning Policy (Exempt and Complying Development Codes) 2008. It is not a statement that exempt development is permissible on the land.

Other land exemptions within State Environmental Planning Policy (Exempt and Complying Development Codes) 2008 may also apply. Furthermore, other provisions within the relevant Local Environmental Plan or a State Environmental Planning Policy which restrict exempt development on the land may also apply.

It is your responsibility to ensure that you comply with the relevant exempt development provisions for the land.

Exempt Development pursuant to the exempt development codes **may** be carried out on the land under **Clauses 1.16(1)(b1)–(d) or Clause 1.16A** of State Environmental Planning Policy (Exempt and Complying Development Codes) 2008.

Complying Development Codes

Note: This does not constitute a Complying Development Certificate under section 4.27 of the Environmental Planning and Assessment Act 1979

Clause 1.12 State Environmental Planning Policy (Exempt and Complying Development Codes) 2008

The land is not land where the complying development codes are varied under Clause 1.12 of State Environmental Planning Policy (Exempt and Complying Development Codes) 2008.

Clauses 1.17A (1) (c) to (e), (2), (3) and (4), 1.18 (1)(c3) and 1.19 of State Environmental Planning Policy (Exempt and Complying Development Codes) 2008

The following information only addresses whether or not the land is land on which complying development may be carried out under each of the codes for complying development because of the provisions of **Clauses 1.17A (1) (c) to (e), (2), (3) and (4), 1.18 (1)(c3) and 1.19** of State Environmental Planning Policy (Exempt and Complying Development Codes) 2008. It is not a statement that complying development is permissible on the land.

Other land exemptions within State Environmental Planning Policy (Exempt and Complying Development Codes) 2008 may also apply. Furthermore, other provisions within the relevant Local Environmental Plan or a State Environmental Planning Policy which restrict complying development on the land may also apply.

It is your responsibility to ensure that you comply with the relevant complying development provisions for the land. Failure to comply with these provisions may mean that a Complying Development Certificate is invalid.

Housing Code, Inland Code, Low Rise Housing Diversity Code, Pattern Book Development Code, Rural Housing Code, Agritourism and Farm Stay Accommodation Code and Greenfield Housing Code

Complying Development pursuant to the Housing Code, Inland Code, Low Rise Housing Diversity Code, Pattern Book Development Code, Rural Housing Code, Agritourism and Farm Stay Accommodation Code and Greenfield Housing Code **may** be carried out on the land under **Clause 1.17A (1) (c) to (e), (2), (3) and (4) and Clause 1.18 (1)(c3) and Clause 1.19** of State Environmental Planning Policy (Exempt and Complying Development Codes) 2008.

Industrial and Business Buildings Code

Complying Development pursuant to the Industrial and Business Buildings Code **may** be carried out on the land under **Clause 1.17A (1) (c) to (e), (2), (3) and (4) and Clause 1.18 (1)(c3) and Clause 1.19** of State Environmental Planning Policy (Exempt and Complying Development Codes) 2008.

Housing Alterations Code; General Development Code; Industrial and Business Alterations Code; Container Recycling Facilities Code; Subdivision Code; Demolition Code; Fire Safety Code

Complying Development pursuant to the Housing Alterations Code, General Development Code, Industrial and Business Alterations Code, Container Recycling Facilities Code, Subdivision Code, Demolition Code and Fire Safety Code **may** be carried out on the land under **Clause 1.17A (1) (c) to (e), (2), (3) and (4) and Clause 1.18 (1)(c3) and Clause 1.19** of State Environmental Planning Policy (Exempt and Complying Development Codes) 2008.

SPECIAL NOTES

The land is identified as Class 5 on the Acid Sulfate Soils map. Refer to Clause 6.1 of Parramatta Local Environmental Plan 2023.

Applicants for Sections 10.7 Certificates are advised that Council does not hold sufficient information to fully detail the effect of any encumbrances on the title of the subject land. The information available to Council is provided on the basis that neither Council nor its servants hold out advice or warrant to you in any way its accuracy, nor shall Council or its servants, be liable for any negligence in the preparation of that information. Further information should be sought from relevant Statutory Departments.

The following additional information is issued under Section 10.7(5)

The following information is provided pursuant to S10.7(5) the Council supplies information as set out below on the basis that the Council takes no responsibility for the accuracy of the information. The information if material should be independently checked by the applicant.

Draft Planning Control Options for All-Electric Buildings outside the Parramatta City Centre - Parramatta Development Control Plan (DCP) 2023.

Council is exhibiting options to amend the Parramatta Development Control Plan (DCP) 2023 to include proposed all-electric building controls for future development. The proposed amendments would apply to future developments outside of the Parramatta City Centre.

Further information can be found at <https://participate.cityofparramatta.nsw.gov.au/all-electric-buildings> or by contacting Council.

Draft A'Becketts Creek Flood Study (Draft Flood Study)

Between 9 December 2025 and 6 February 2026, Council is exhibiting the Draft A'Becketts Creek Flood Study.

Further information about the Draft A'Becketts Creek Flood Study can be found at <https://participate.cityofparramatta.nsw.gov.au/abecketts> or by contacting Council

Draft Parramatta River Flood Study (Draft Flood Study)

Between 18 September 2023 and 30 October 2023, Council is exhibiting the Draft Parramatta River Flood Study.

Further information about the Draft Parramatta River Flood Study can be found at <https://participate.cityofparramatta.nsw.gov.au/flood-study> or by contacting Council.

Grey Area / Grey Hatched Area

The land the subject of this certificate is within an area shown as grey / grey hatched on Figure 1 – Drainage and Flooding Constraints Map of the “Parramatta Drainage” Study Report dated March 1990.

Grey / grey hatched areas are areas which experience drainage problems from the local catchment and development of properties within these areas are subject to additional site drainage controls to manage these problems.

Further information in relation to development of properties within grey / grey hatched areas is available from Council’s Development and Traffic Services Section.

Detail in regard to the extent of grey / grey hatched areas is available from Council’s Catchment Management Section.

Explanation of Intended Effect – Cultural State Environmental Planning Policy

Explanation of Intended Effect (EIE) – Cultural State Environmental Planning Policy (November 2024) may be applicable. The EIE proposes changes to the planning

system to support more creative, hospitality and cultural uses contributing to the 24-hour economy, and also proposes changes to food trucks in residential zones; and changes to allow bicycle rails and bicycle lockers as exempt development.

Please see [Explanation of Intended Effect: Cultural State Environmental Planning Policy \(SEPP\) | Planning Portal - Department of Planning and Environment](#) for more information.

Note: Advisory Information regarding Combustible Cladding

External combustible cladding on multi-storey buildings has been identified in local government areas including the City of Parramatta. Combustible cladding is a material that is capable of readily burning.

You should make your own enquiries as to the type of materials that have been used to construct the building. It is recommended that the purchaser obtain a building report from an appropriately qualified person to determine if any cladding type material may pose a risk to the building's occupants. Council may issue orders to rectify a building where combustible cladding is found.

Properties that have combustible cladding on buildings are listed in the NSW Government Combustible Cladding Register. Please refer to <https://www.claddingregistration.nsw.gov.au/> or call 1300 305 695 for further information regarding the NSW Government Combustible Cladding Register.

There is potential for combustible cladding to be present on buildings that are not listed on the Register.

Note: Advisory Information regarding Loose-Fill asbestos Insulation

Research undertaken by the Loose-Fill Asbestos Insulation Taskforce has determined that there is a potential for loose-fill asbestos insulation to be found in residential dwellings constructed prior to 1980 in 28 local government areas including the City of Parramatta.

Some residential homes located in the City of Parramatta may contain loose-fill asbestos insulation, for example in the roof space. NSW Fair Trading maintains a Register of homes that are affected by loose-fill asbestos insulation.

You should make your own enquiries as to the age of the buildings on the land to which this certificate relates and, if it contains a building constructed prior to 1980, the council strongly recommends that any potential purchaser obtain advice from a licensed asbestos assessor to determine whether loose fill asbestos is present in any building on the land and, if so, the health risks (if any) this may pose for the building's occupants.

Please Contact NSW Fair Trading for further information.

This information has been provided pursuant to section 10.7(5) of the Environmental Planning and Assessment Act, 1979 as amended.

George Bounassif
Acting Chief Executive Officer

per

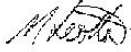

dated 20 March 2026

Sewer Service Diagram

Application Number: 8005113644

Copy of Diagram No. 522863

Form 77/044 (Rev. 07/2017) S217 (44) Water Board Printing Services

SEWERAGE SERVICE DIAGRAM
MUNICIPALITY OF PARRAMATTA
SUBURB OF EPPING

M.W.S. & D.B.

Scale: Approx. 1:500
Distances/depths in metres pipe diameters in millimetres

SEWER AVAILABLE
Where the sewer is not available and a special inspection is involved the Board accepts no responsibility for the suitability of the drainage in relation to the eventual position of the Board's sewer. The existence and position of the Board's sewers, stormwater channels, pipes, mains and structures should be ascertained by inspection of records available at Board's Business Offices. Section 33 Of Board's Act. Position of structures, trees and other above ground items are approximate only and it is advised the holder of this diagram should refer to an initial building plans submitted to the Board. Discrepancies in outline can occur from amendment to these plans. Discrepancies in position and type of drainage lines and fittings can be due to unnotified work. Before building work is commenced location of drainage lines is recommended. Licensee is required to submit to the Board a Certificate Of Compliance as not all work may have been supervised.

NOTE: This diagram only indicates availability of a sewer and any other services shown as existing in Board's records (By-Law 5, Clause 31).

SYMBOLS AND ABBREVIATIONS

INDICATES - DRAINAGE FITTINGS

- Manhole
- Chamber
- Lamphole
- Boundary Trap
- Inspection Shaft
- Grease Interceptor
- Gully
- P. Trap
- Reflux Valve
- Cleaning Eye
- Vertical Pipe
- Induct Pipe
- Mica Trap
- Junction
- Rodding Point

INDICATES - PLUMBING FIXTURES & OR FITTINGS

- CO Clear Out
- V Vent Pipe
- T Tube
- K Kitchen Sink
- W Water Closet
- B Bath
- H Handbasin
- LS Lab Sink
- Waste Stack
- Buf Bidet
- S Shower
- DW Dishwasher
- F Floor Waste
- M Washing Machine
- BS Bar Sink
- LS Lab Sink
- Waste Stack

INDICATES - PLUMBING ON MORE THAN ONE LEVEL

- SV Soil Vent Pipe
- MS Waste Stack

DRAINAGE INSPECTED BY

Inspector: _____

Cert. Of Compliance No. _____

Field Diagram Examined by

Tracing Checked by _____

PLUMBING INSPECTED

Inspector	YES	NO
-----------	-----	----

Cert. Of Compliance No. _____

Date of Issue _____

Outfall _____

W/s _____ **Ur's** _____ **Plumber** _____

W.No. _____ **Gas. on** _____

Boundary Trap is not required

Sewer Ref. Sheet _____

No. _____ **For Regional Manager** _____

Copy of Diagram No. 522863

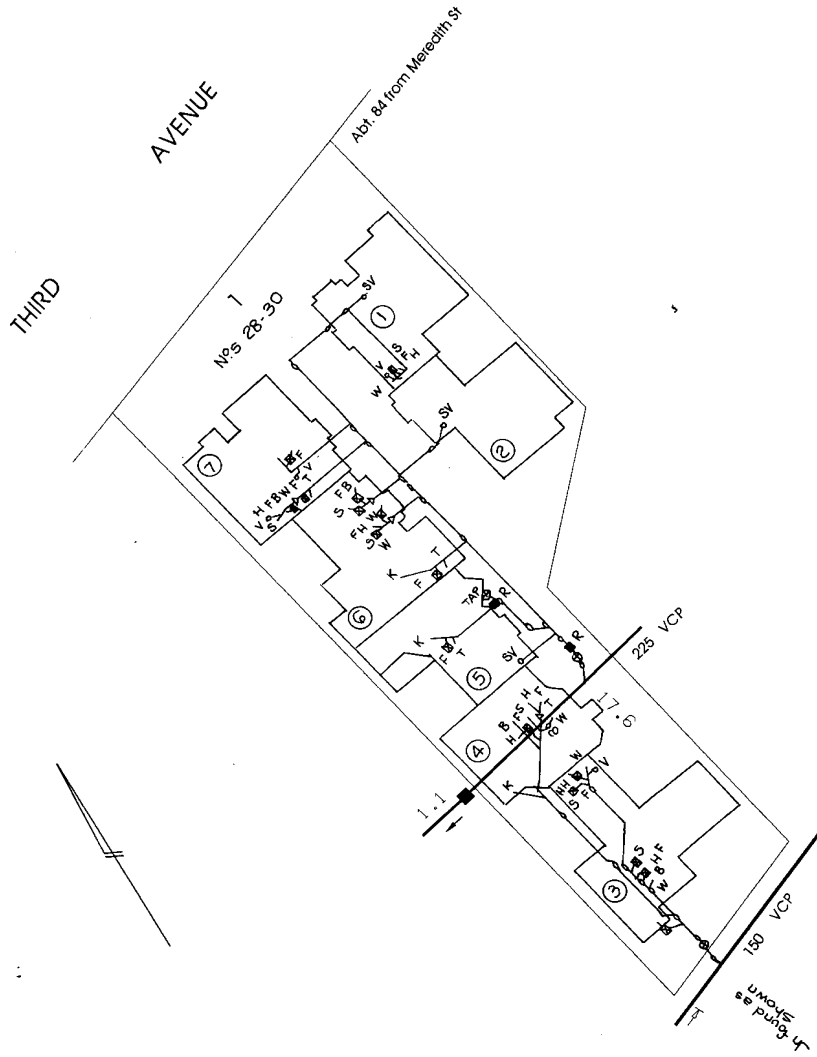

Document generated at 20-03-2026 04:23:11 PM

Disclaimer

The information in this diagram shows the private wastewater pipes on this property. It may not be accurate or to scale and may not show our pipes, structures or all property boundaries. If you'd like to see these, please buy a **Service location print**.

Asset Information

Legend

Sewer		Property Details	
Sewer Main (with flow arrow & size type text)		Boundary Line	
Disused Main		Easement Line	
Rising Main		House Number	
Maintenance Hole (with upstream depth to invert)		Lot Number	
Sub-surface chamber		Proposed Land	
Maintenance Hole with Overflow chamber		Sydney Water Heritage Site (please call 132 092 and ask for the Heritage Unit)	
Ventshaft EDUCT			
Ventshaft INDUCT			
Property Connection Point (with chainage to downstream MH)			
Concrete Encased Section			
Terminal Maintenance Shaft			
Maintenance Shaft			
Rodding Point			
Lamphole			
Vertical			
Pumping Station			
Sewer Rehabilitation			
Pressure Sewer		Water	
Pressure Sewer Main		WaterMain - Potable (with size type text)	
Pump Unit (Alarm, Electrical Cable, Pump Unit)		Disconnected Main - Potable	
Property Valve Boundary Assembly		Proposed Main - Potable	
Stop Valve		Water Main - Recycled	
Reducer / Taper		Special Supply Conditions - Potable	
Flushing Point		Special Supply Conditions - Recycled	
		Restrained Joints - Potable	
		Restrained Joints - Recycled	
		Hydrant	
		Maintenance Hole	
		Stop Valve	
		Stop Valve with By-pass	
		Stop Valve with Tapers	
		Closed Stop Valve	
		Air Valve	
		Valve	
		Scour	
		Reducer / Taper	
		Vertical Bends	
		Reservoir	
		Recycled Water is shown as per Potable above. Colour as indicated	
Vacuum Sewer		Private Mains	
Pressure Sewer Main		Potable Water Main	
Division Valve		Recycled Water Main	
Vacuum Chamber		Sewer Main	
Clean Out Point		Symbols for Private Mains shown grey	
Stormwater			
Stormwater Pipe			
Stormwater Channel			
Stormwater Gully			
Stormwater Maintenance Hole			

Disclaimer

The information on this print shows if we provide any water, wastewater or stormwater services to this property. It may not be accurate or to scale. If you'd like to see the location of private wastewater pipes on the property, please buy a **Sewer service diagram**.

Pipe Types

ABS	Acrylonitrile Butadiene Styrene	AC	Asbestos Cement
BRICK	Brick	CI	Cast Iron
CICL	Cast Iron Cement Lined	CONC	Concrete
COPPER	Copper	DI	Ductile Iron
DICL	Ductile Iron Cement (mortar) Lined	DIPL	Ductile Iron Polymeric Lined
EW	Earthenware	FIBG	Fibreglass
FL BAR	Forged Locking Bar	GI	Galvanised Iron
GRP	Glass Reinforced Plastics	HDPE	High Density Polyethylene
MS	Mild Steel	MSCL	Mild Steel Cement Lined
PE	Polyethylene	PC	Polymer Concrete
PP	Polypropylene	PVC	Polyvinylchloride
PVC - M	Polyvinylchloride, Modified	PVC - O	Polyvinylchloride, Oriented
PVC - U	Polyvinylchloride, Unplasticised	RC	Reinforced Concrete
RC-PL	Reinforced Concrete Plastics Lined	S	Steel
SCL	Steel Cement (mortar) Lined	SCL IBL	Steel Cement Lined Internal Bitumen Lined
SGW	Salt Glazed Ware	SPL	Steel Polymeric Lined
SS	Stainless Steel	STONE	Stone
VC	Vitrified Clay	WI	Wrought Iron
WS	Woodstave		

Further Information

Please consult the Dial Before You Dig enquiries page on the Sydney Water website.

For general enquiries please call the Customer Contact Centre on 132 092

In an emergency, or to notify Sydney Water of damage or threats to its structures, call 13 20 90 (24 hours, 7 days)

Disclaimer

The information on this print shows if we provide any water, wastewater or stormwater services to this property. It may not be accurate or to scale. If you'd like to see the location of private wastewater pipes on the property, please buy a **Sewer service diagram**.