

Contract for the sale and purchase of land 2019 edition

TERM	MEANING OF TERM	NSW DAN:
vendor's agent	Stone Real Estate Tumbi Umbi and Berkeley Vale 1B/31 Tumbi Road, Tumbi Umbi, NSW 2261	Phone: 4388 8888 Ref: Volkan Akintetik
co-agent		
vendor	Andrew Stuart Blythin 16 William Street, Balmain East, NSW 2041	
vendor's solicitor	Link Legal & Conveyancing 374 Main Road, Norville NSW 2263 PO Box 104, TOUKLEY NSW 2263	Phone: 02 4302 1698 Email: reception@llac.com.au Ref: LN:RP:223384
date for completion land (address, plan details and title reference)	42nd day after the contract date 3/7 King Street, Ourimbah, New South Wales 2258 Registered Plan: Lot 3 Plan SP 69646 Folio Identifier 3/SP69646	(clause 15)

improvements VACANT POSSESSION subject to existing tenancies
 HOUSE garage carport home unit carspace storage space
 none other:

attached copies documents in the List of Documents as marked or as numbered:
 other documents:

A real estate agent is permitted by legislation to fill up the items in this box in a sale of residential property.

inclusions	<input checked="" type="checkbox"/> blinds	<input type="checkbox"/> dishwasher	<input type="checkbox"/> light fittings	<input type="checkbox"/> stove
	<input type="checkbox"/> built-in wardrobes	<input type="checkbox"/> fixed floor coverings	<input type="checkbox"/> range hood	<input type="checkbox"/> pool equipment
	<input type="checkbox"/> clothes line	<input checked="" type="checkbox"/> insect screens	<input type="checkbox"/> solar panels	<input type="checkbox"/> TV antenna
	<input type="checkbox"/> curtains	<input type="checkbox"/> other:		
exclusions				
purchaser				
purchaser's solicitor				
price	\$			
deposit	\$			(10% of the price, unless otherwise stated)
balance	\$			
contract date				(if not stated, the date this contract was made)

buyer's agent

vendor

GST AMOUNT (optional)

The price includes
 GST of: \$

witness

purchaser JOINT TENANTS tenants in common in unequal shares

witness

ChoicesVendor agrees to accept a **deposit-bond** (clause 3) NO yes**Nominated Electronic Lodgment Network (ELN)** (clause 30):

PEXA

Electronic transaction (clause 30) no YES(if no, vendor must provide further details, such as the proposed applicable waiver, in the space below, or serve *within* 14 days of the contract date):**Tax information (the parties promise this is correct as far as each party is aware)**

Land tax is adjustable

 NO yes

GST: Taxable supply

 NO yes in full yes to an extent

Margin scheme will be used in making the taxable supply

 NO yes

This sale is not a taxable supply because (one or more of the following may apply) the sale is:

 not made in the course or furtherance of an enterprise that the vendor carries on (section 9-5(b)) by a vendor who is neither registered nor required to be registered for GST (section 9-5(d)) GST-free because the sale is the supply of a going concern under section 38-325 GST-free because the sale is subdivided farm land or farm land supplied for farming under Subdivision 38-O input taxed because the sale is of eligible residential premises (sections 40-65, 40-75(2) and 195-1)Purchaser must make a *GSTRW payment*
(GST residential withholding payment) NO yes (if yes, vendor must provide further details)If the further details below are not fully completed at the contract date, the vendor must provide all these details in a separate notice *within* 14 days of the contract date.**GSTRW payment (GST residential withholding payment) – further details**

Frequently the supplier will be the vendor. However, sometimes further information will be required as to which entity is liable for GST, for example, if the supplier is a partnership, a trust, part of a GST group or a participant in a GST joint venture.

Supplier's name:

Supplier's ABN:

Supplier's GST branch address (if applicable):

Supplier's business address:

Supplier's email address:

Supplier's phone number:

Supplier's proportion of *GSTRW payment*:**If more than one supplier, provide the above details for each supplier.**Amount purchaser must pay – price multiplied by the *GSTRW rate* (residential withholding rate):Amount must be paid: AT COMPLETION at another time (specify):Is any of the consideration not expressed as an amount in money? NO yes

If "yes", the GST inclusive market value of the non-monetary consideration: \$

Other details (including those required by regulation or the ATO forms):

List of Documents

General	Strata or community title (clause 23 of the contract)
<input checked="" type="checkbox"/> 1 property certificate for the land <input checked="" type="checkbox"/> 2 plan of the land <input type="checkbox"/> 3 unregistered plan of the land <input type="checkbox"/> 4 plan of land to be subdivided <input type="checkbox"/> 5 document that is to be lodged with a relevant plan <input checked="" type="checkbox"/> 6 section 10.7(2) planning certificate under Environmental Planning and Assessment Act 1979 <input type="checkbox"/> 7 additional information included in that certificate under section 10.7(5) <input checked="" type="checkbox"/> 8 sewerage infrastructure location diagram (service location diagram) <input checked="" type="checkbox"/> 9 sewer lines location diagram (sewerage service diagram) <input type="checkbox"/> 10 document that created or may have created an easement, profit à prendre, restriction on use or positive covenant disclosed in this contract <input type="checkbox"/> 11 <i>planning agreement</i> <input type="checkbox"/> 12 section 88G certificate (positive covenant) <input type="checkbox"/> 13 survey report <input type="checkbox"/> 14 building information certificate or building certificate given under <i>legislation</i> <input type="checkbox"/> 15 lease (with every relevant memorandum or variation) <input type="checkbox"/> 16 other document relevant to tenancies <input type="checkbox"/> 17 licence benefiting the land <input type="checkbox"/> 18 old system document <input type="checkbox"/> 19 Crown purchase statement of account <input type="checkbox"/> 20 building management statement <input checked="" type="checkbox"/> 21 form of requisitions <input type="checkbox"/> 22 <i>clearance certificate</i> <input type="checkbox"/> 23 land tax certificate	<input type="checkbox"/> 32 property certificate for strata common property <input checked="" type="checkbox"/> 33 plan creating strata common property <input checked="" type="checkbox"/> 34 strata by-laws <input type="checkbox"/> 35 strata development contract or statement <input type="checkbox"/> 36 strata management statement <input type="checkbox"/> 37 strata renewal proposal <input type="checkbox"/> 38 strata renewal plan <input type="checkbox"/> 39 leasehold strata - lease of lot and common property <input type="checkbox"/> 40 property certificate for neighbourhood property <input type="checkbox"/> 41 plan creating neighbourhood property <input type="checkbox"/> 42 neighbourhood development contract <input type="checkbox"/> 43 neighbourhood management statement <input type="checkbox"/> 44 property certificate for precinct property <input type="checkbox"/> 45 plan creating precinct property <input type="checkbox"/> 46 precinct development contract <input type="checkbox"/> 47 precinct management statement <input type="checkbox"/> 48 property certificate for community property <input type="checkbox"/> 49 plan creating community property <input type="checkbox"/> 50 community development contract <input type="checkbox"/> 51 community management statement <input type="checkbox"/> 52 document disclosing a change of by-laws <input type="checkbox"/> 53 document disclosing a change in a development or management contract or statement <input type="checkbox"/> 54 document disclosing a change in boundaries <input type="checkbox"/> 55 information certificate under Strata Schemes Management Act 2015 <input type="checkbox"/> 56 information certificate under Community Land Management Act 1989 <input type="checkbox"/> 57 disclosure statement - off the plan contract <input type="checkbox"/> 58 other document relevant to off the plan contract Other <input type="checkbox"/> 59
Home Building Act 1989 <input type="checkbox"/> 24 insurance certificate <input type="checkbox"/> 25 brochure or warning <input type="checkbox"/> 26 evidence of alternative indemnity cover Swimming Pools Act 1992 <input type="checkbox"/> 27 certificate of compliance <input type="checkbox"/> 28 evidence of registration <input type="checkbox"/> 29 relevant occupation certificate <input type="checkbox"/> 30 certificate of non-compliance <input type="checkbox"/> 31 detailed reasons of non-compliance	

HOLDER OF STRATA OR COMMUNITY TITLE RECORDS – Name, address, email address and telephone number

All Strata Services

Lot 16, Tuggerah Corporate Centre, 1 Bounty Close, Tuggerah, NSW 2259

Phone: 43519699

allstrata@allstrataservices.com.au

IMPORTANT NOTICE TO VENDORS AND PURCHASERS

Before signing this contract you should ensure that you understand your rights and obligations, some of which are not written in this contract but are implied by law.

WARNING—SMOKE ALARMS

The owners of certain types of buildings and strata lots must have smoke alarms (or in certain cases heat alarms) installed in the building or lot in accordance with regulations under the *Environmental Planning and Assessment Act 1979*. It is an offence not to comply. It is also an offence to remove or interfere with a smoke alarm or heat alarm. Penalties apply.

WARNING—LOOSE-FILL ASBESTOS INSULATION

Before purchasing land that includes any residential premises (within the meaning of Division 1A of Part 8 of the *Home Building Act 1989*) built before 1985, a purchaser is strongly advised to consider the possibility that the premises may contain loose-fill asbestos insulation (within the meaning of Division 1A of Part 8 of the *Home Building Act 1989*). In particular, a purchaser should:

- (a) search the Register required to be maintained under Division 1A of Part 8 of the *Home Building Act 1989*, and
- (b) ask the relevant local council whether it holds any records showing that the residential premises contain loose-fill asbestos insulation.

For further information about loose-fill asbestos insulation (including areas in which residential premises have been identified as containing loose-fill asbestos insulation), contact NSW Fair Trading.

COOLING OFF PERIOD (PURCHASER'S RIGHTS)

1. This is the statement required by section 66X of the *Conveyancing Act 1919* and applies to a contract for the sale of residential property.
2. **EXCEPT** in the circumstances listed in paragraph 3, the purchaser may rescind the contract at any time before 5 pm on—
 - (a) the tenth business day after the day on which the contract was made—in the case of an off the plan contract, or
 - (b) the fifth business day after the day on which the contract was made—in any other case.
3. There is **NO COOLING OFF PERIOD**:
 - (a) if, at or before the time the contract is made, the purchaser gives to the vendor (or the vendor's solicitor or agent) a certificate that complies with section 66W of the Act, or
 - (b) if the property is sold by public auction, or
 - (c) if the contract is made on the same day as the property was offered for sale by public auction but passed in, or
 - (d) if the contract is made in consequence of the exercise of an option to purchase the property, other than an option that is void under section 66ZG of the Act.
4. A purchaser exercising the right to cool off by rescinding the contract will forfeit to the vendor 0.25% of the purchase price of the property. The vendor is entitled to recover the amount forfeited from any amount paid by the purchaser as a deposit under the contract and the purchaser is entitled to a refund of any balance.

DISPUTES

If you get into a dispute with the other party, the Law Society and Real Estate Institute encourage you to use informal procedures such as negotiation, independent expert appraisal, the Law Society Conveyancing Dispute Resolution Scheme or mediation (for example mediation under the Law Society Mediation Program).

AUCTIONS

Regulations made under the Property, Stock and Business Agents Act 2002 prescribe a number of conditions applying to sales by auction.

WARNINGS

1. Various Acts of Parliament and other matters can affect the rights of the parties to this contract. Some important matters are actions, claims, decisions, licences, notices, orders, proposals or rights of way involving:

APA Group Australian Taxation Office Council County Council Department of Planning, Industry and Environment Department of Primary Industries Electricity and gas Land & Housing Corporation Local Land Services	NSW Department of Education NSW Fair Trading Owner of adjoining land Privacy Public Works Advisory Subsidence Advisory NSW Telecommunications Transport for NSW Water, sewerage or drainage authority
---	--

If you think that any of these matters affects the property, tell your solicitor.
2. A lease may be affected by the Agricultural Tenancies Act 1990, the Residential Tenancies Act 2010 or the Retail Leases Act 1994.
3. If any purchase money is owing to the Crown, it will become payable before obtaining consent, or if no consent is needed, when the transfer is registered.
4. If a consent to transfer is required under legislation, see clause 27 as to the obligations of the parties.
5. The vendor should continue the vendor's insurance until completion. If the vendor wants to give the purchaser possession before completion, the vendor should first ask the insurer to confirm this will not affect the insurance.
6. The purchaser will usually have to pay transfer duty (and sometimes surcharge purchaser duty) on this contract. If duty is not paid on time, a purchaser may incur penalties.
7. If the purchaser agrees to the release of deposit, the purchaser's right to recover the deposit may stand behind the rights of others (for example the vendor's mortgagee).
8. The purchaser should arrange insurance as appropriate.
9. Some transactions involving personal property may be affected by the Personal Property Securities Act 2009.
10. A purchaser should be satisfied that finance will be available at the time of completing the purchase.
11. Where the market value of the property is at or above a legislated amount, the purchaser may have to comply with a foreign resident capital gains withholding payment obligation (even if the vendor is not a foreign resident). If so, this will affect the amount available to the vendor on completion.
12. Purchasers of some residential properties may have to withhold part of the purchase price to be credited towards the GST liability of the vendor. If so, this will also affect the amount available to the vendor. More information is available from the ATO.

The vendor sells and the purchaser buys the *property* for the price under these provisions instead of Schedule 3 Conveyancing Act 1919, subject to any *legislation* that cannot be excluded.

1 Definitions (a term in italics is a defined term)

In this contract, these terms (in any form) mean –

<i>adjustment date</i>	the earlier of the giving of possession to the purchaser or completion;
<i>bank</i>	the Reserve Bank of Australia or an authorised deposit-taking institution which is a bank, a building society or a credit union;
<i>business day</i>	any day except a bank or public holiday throughout NSW or a Saturday or Sunday;
<i>cheque</i>	a cheque that is not postdated or stale;
<i>clearance certificate</i>	a certificate within the meaning of s14-220 of Schedule 1 to the <i>TA Act</i> , that covers one or more days falling within the period from and including the contract date to completion;
<i>deposit-bond</i>	a deposit bond or guarantee from an issuer, with an expiry date and for an amount each approved by the vendor;
<i>depositholder</i>	vendor's agent (or if no vendor's agent is named in this contract, the vendor's <i>solicitor</i> , or if no vendor's <i>solicitor</i> is named in this contract, the buyer's agent);
<i>document of title</i>	document relevant to the title or the passing of title;
<i>FRCGW percentage</i>	the percentage mentioned in s14-200(3)(a) of Schedule 1 to the <i>TA Act</i> (12.5% as at 1 July 2017);
<i>FRCGW remittance</i>	a remittance which the purchaser must make under s14-200 of Schedule 1 to the <i>TA Act</i> , being the lesser of the <i>FRCGW percentage</i> of the price (inclusive of GST, if any) and the amount specified in a <i>variation served by a party</i> ;
<i>GST Act</i>	A New Tax System (Goods and Services Tax) Act 1999;
<i>GST rate</i>	the rate mentioned in s4 of A New Tax System (Goods and Services Tax Imposition - General) Act 1999 (10% as at 1 July 2000);
<i>GSTRW payment</i>	a payment which the purchaser must make under s14-250 of Schedule 1 to the <i>TA Act</i> (the price multiplied by the <i>GSTRW rate</i>);
<i>GSTRW rate</i>	the rate determined under ss14-250(6), (8) or (9) of Schedule 1 to the <i>TA Act</i> (as at 1 July 2018, usually 7% of the price if the margin scheme applies, 1/11 th if not);
<i>legislation</i>	an Act or a by-law, ordinance, regulation or rule made under an Act;
<i>normally</i>	subject to any other provision of this contract;
<i>party</i>	each of the vendor and the purchaser;
<i>property</i>	the land, the improvements, all fixtures and the inclusions, but not the exclusions;
<i>planning agreement</i>	a valid voluntary agreement within the meaning of s7.4 of the Environmental Planning and Assessment Act 1979 entered into in relation to the <i>property</i> ;
<i>requisition</i>	an objection, question or requisition (but the term does not include a claim);
<i>rescind</i>	rescind this contract from the beginning;
<i>serve</i>	serve in writing on the other <i>party</i> ;
<i>settlement cheque</i>	an unendorsed <i>cheque</i> made payable to the person to be paid and – <ul style="list-style-type: none"> ● issued by a <i>bank</i> and drawn on itself; or ● if authorised in writing by the vendor or the vendor's <i>solicitor</i>, some other <i>cheque</i>;
<i>solicitor</i>	in relation to a <i>party</i> , the <i>party's</i> solicitor or licensed conveyancer named in this contract or in a notice <i>served by the party</i> ;
<i>TA Act</i>	Taxation Administration Act 1953;
<i>terminate</i>	terminate this contract for breach;
<i>variation</i>	a variation made under s14-235 of Schedule 1 to the <i>TA Act</i> ;
<i>within</i>	in relation to a period, at any time before or during the period; and
<i>work order</i>	a valid direction, notice or order that requires work to be done or money to be spent on or in relation to the <i>property</i> or any adjoining footpath or road (but the term does not include a notice under s22E of the Swimming Pools Act 1992 or clause 22 of the Swimming Pools Regulation 2018).

2 Deposit and other payments before completion

- 2.1 The purchaser must pay the deposit to the *depositholder* as stakeholder.
- 2.2 *Normally*, the purchaser must pay the deposit on the making of this contract, and this time is essential.
- 2.3 If this contract requires the purchaser to pay any of the deposit by a later time, that time is also essential.
- 2.4 The purchaser can pay any of the deposit by giving cash (up to \$2,000) or by unconditionally giving a *cheque* to the *depositholder* or to the vendor, vendor's agent or vendor's *solicitor* for sending to the *depositholder* or by payment by electronic funds transfer to the *depositholder*.
- 2.5 If any of the deposit is not paid on time or a *cheque* for any of the deposit is not honoured on presentation, the vendor can *terminate*. This right to *terminate* is lost as soon as the deposit is paid in full.
- 2.6 If the vendor accepts a bond or guarantee for the deposit, clauses 2.1 to 2.5 do not apply.

BREACH OF COPYRIGHT MAY RESULT IN LEGAL ACTION

- 2.7 If the vendor accepts a bond or guarantee for part of the deposit, clauses 2.1 to 2.5 apply only to the balance.
- 2.8 If any of the deposit or of the balance of the price is paid before completion to the vendor or as the vendor directs, it is a charge on the land in favour of the purchaser until *termination* by the vendor or completion, subject to any existing right.
- 2.9 If each *party* tells the *depositholder* that the deposit is to be invested, the *depositholder* is to invest the deposit (at the risk of the *party* who becomes entitled to it) with a *bank*, in an interest-bearing account in NSW, payable at call, with interest to be reinvested, and pay the interest to the *parties* equally, after deduction of all proper government taxes and financial institution charges and other charges.

3 Deposit-bond

- 3.1 This clause applies only if this contract says the vendor has agreed to accept a *deposit-bond* for the deposit (or part of it).
- 3.2 The purchaser must provide the original *deposit-bond* to the vendor's *solicitor* (or if no *solicitor* the *depositholder*) at or before the making of this contract and this time is essential.
- 3.3 If the *deposit-bond* has an expiry date and completion does not occur by the date which is 14 days before the expiry date, the purchaser must *serve* a replacement *deposit-bond* at least 7 days before the expiry date. The time for service is essential.
- 3.4 The vendor must approve a replacement *deposit-bond* if –
- 3.4.1 it is from the same issuer and for the same amount as the earlier *deposit-bond*; and
- 3.4.2 it has an expiry date at least three months after its date of issue.
- 3.5 A breach of clauses 3.2 or 3.3 entitles the vendor to *terminate*. The right to *terminate* is lost as soon as –
- 3.5.1 the purchaser *serves* a replacement *deposit-bond*; or
- 3.5.2 the deposit is paid in full under clause 2.
- 3.6 Clauses 3.3 and 3.4 can operate more than once.
- 3.7 If the purchaser *serves* a replacement *deposit-bond*, the vendor must *serve* the earlier *deposit-bond*.
- 3.8 The amount of any *deposit-bond* does not form part of the price for the purposes of clause 16.7.
- 3.9 The vendor must give the purchaser the *deposit-bond* –
- 3.9.1 on completion; or
- 3.9.2 if this contract is *rescinded*.
- 3.10 If this contract is *terminated* by the vendor –
- 3.10.1 *normally*, the vendor can immediately demand payment from the issuer of the *deposit-bond*; or
- 3.10.2 if the purchaser *serves* prior to *termination* a notice disputing the vendor's right to *terminate*, the vendor must forward the *deposit-bond* (or its proceeds if called up) to the *depositholder* as stakeholder.
- 3.11 If this contract is *terminated* by the purchaser –
- 3.11.1 *normally*, the vendor must give the purchaser the *deposit-bond*; or
- 3.11.2 if the vendor *serves* prior to *termination* a notice disputing the purchaser's right to *terminate*, the vendor must forward the *deposit-bond* (or its proceeds if called up) to the *depositholder* as stakeholder.

4 Transfer

- 4.1 *Normally*, the purchaser must *serve* at least 14 days before the date for completion –
- 4.1.1 the form of transfer; and
- 4.1.2 particulars required to register any mortgage or other dealing to be lodged with the transfer by the purchaser or the purchaser's mortgagee.
- 4.2 If any information needed for the form of transfer is not disclosed in this contract, the vendor must *serve* it.
- 4.3 If the purchaser *serves* a form of transfer and the transferee is not the purchaser, the purchaser must give the vendor a direction signed by the purchaser personally for this form of transfer.
- 4.4 The vendor can require the purchaser to include a form of covenant or easement in the transfer only if this contract contains the wording of the proposed covenant or easement, and a description of the land benefited.

5 Requisitions

- 5.1 If a form of *requisitions* is attached to this contract, the purchaser is taken to have made those *requisitions*.
- 5.2 If the purchaser is or becomes entitled to make any other *requisition*, the purchaser can make it only by *serving* it –
- 5.2.1 if it arises out of this contract or it is a general question about the *property* or title - *within* 21 days after the contract date;
- 5.2.2 if it arises out of anything *served* by the vendor - *within* 21 days after the later of the contract date and that *service*; and
- 5.2.3 in any other case - *within* a reasonable time.

6 Error or misdescription

- 6.1 *Normally*, the purchaser can (but only before completion) claim compensation for an error or misdescription in this contract (as to the *property*, the title or anything else and whether substantial or not).
- 6.2 This clause applies even if the purchaser did not take notice of or rely on anything in this contract containing or giving rise to the error or misdescription.
- 6.3 However, this clause does not apply to the extent the purchaser knows the true position.

7 Claims by purchaser

Normally, the purchaser can make a claim (including a claim under clause 6) before completion only by *servicing* it with a statement of the amount claimed, and if the purchaser makes one or more claims before completion –

- 7.1 the vendor can *rescind* if in the case of claims that are not claims for delay –
- 7.1.1 the total amount claimed exceeds 5% of the price;
- 7.1.2 the vendor *serves* notice of intention to *rescind*; and
- 7.1.3 the purchaser does not *serve* notice waiving the claims *within* 14 days after that *service*; and
- 7.2 if the vendor does not *rescind*, the *parties* must complete and if this contract is completed –
- 7.2.1 the lesser of the total amount claimed and 10% of the price must be paid out of the price to and held by the *depositholder* until the claims are finalised or lapse;
- 7.2.2 the amount held is to be invested in accordance with clause 2.9;
- 7.2.3 the claims must be finalised by an arbitrator appointed by the *parties* or, if an appointment is not made *within* 1 month of completion, by an arbitrator appointed by the President of the Law Society at the request of a *party* (in the latter case the *parties* are bound by the terms of the Conveyancing Arbitration Rules approved by the Law Society as at the date of the appointment);
- 7.2.4 the purchaser is not entitled, in respect of the claims, to more than the total amount claimed and the costs of the purchaser;
- 7.2.5 net interest on the amount held must be paid to the *parties* in the same proportion as the amount held is paid; and
- 7.2.6 if the *parties* do not appoint an arbitrator and neither *party* requests the President to appoint an arbitrator *within* 3 months after completion, the claims lapse and the amount belongs to the vendor.

8 Vendor's rights and obligations

- 8.1 The vendor can *rescind* if –
- 8.1.1 the vendor is, on reasonable grounds, unable or unwilling to comply with a *requisition*;
- 8.1.2 the vendor *serves* a notice of intention to *rescind* that specifies the *requisition* and those grounds; and
- 8.1.3 the purchaser does not *serve* a notice waiving the *requisition within* 14 days after that *service*.
- 8.2 If the vendor does not comply with this contract (or a notice under or relating to it) in an essential respect, the purchaser can *terminate* by *servicing* a notice. After the *termination* –
- 8.2.1 the purchaser can recover the deposit and any other money paid by the purchaser under this contract;
- 8.2.2 the purchaser can sue the vendor to recover damages for breach of contract; and
- 8.2.3 if the purchaser has been in possession a *party* can claim for a reasonable adjustment.

9 Purchaser's default

If the purchaser does not comply with this contract (or a notice under or relating to it) in an essential respect, the vendor can *terminate* by *servicing* a notice. After the *termination* the vendor can –

- 9.1 keep or recover the deposit (to a maximum of 10% of the price);
- 9.2 hold any other money paid by the purchaser under this contract as security for anything recoverable under this clause –
- 9.2.1 for 12 months after the *termination*; or
- 9.2.2 if the vendor commences proceedings under this clause *within* 12 months, until those proceedings are concluded; and
- 9.3 sue the purchaser either –
- 9.3.1 where the vendor has resold the *property* under a contract made *within* 12 months after the *termination*, to recover –
- the deficiency on resale (with credit for any of the deposit kept or recovered and after allowance for any capital gains tax or goods and services tax payable on anything recovered under this clause); and
 - the reasonable costs and expenses arising out of the purchaser's non-compliance with this contract or the notice and of resale and any attempted resale; or
- 9.3.2 to recover damages for breach of contract.

10 Restrictions on rights of purchaser

- 10.1 The purchaser cannot make a claim or *requisition* or *rescind* or *terminate* in respect of –
- 10.1.1 the ownership or location of any fence as defined in the Dividing Fences Act 1991;
- 10.1.2 a service for the *property* being a joint service or passing through another property, or any service for another property passing through the *property* ('service' includes air, communication, drainage, electricity, garbage, gas, oil, radio, sewerage, telephone, television or water service);
- 10.1.3 a wall being or not being a party wall in any sense of that term or the *property* being affected by an easement for support or not having the benefit of an easement for support;
- 10.1.4 any change in the *property* due to fair wear and tear before completion;
- 10.1.5 a promise, representation or statement about this contract, the *property* or the title, not set out or referred to in this contract;
- 10.1.6 a condition, exception, reservation or restriction in a Crown grant;

- 10.1.7 the existence of any authority or licence to explore or prospect for gas, minerals or petroleum;
- 10.1.8 any easement or restriction on use the substance of either of which is disclosed in this contract or any non-compliance with the easement or restriction on use; or
- 10.1.9 anything the substance of which is disclosed in this contract (except a caveat, charge, mortgage, priority notice or writ).
- 10.2 The purchaser cannot *rescind* or *terminate* only because of a defect in title to or quality of the inclusions.
- 10.3 *Normally*, the purchaser cannot make a claim or *requisition* or *rescind* or *terminate* or require the vendor to change the nature of the title disclosed in this contract (for example, to remove a caution evidencing qualified title, or to lodge a plan of survey as regards limited title).
- 11 Compliance with work orders**
- 11.1 *Normally*, the vendor must by completion comply with a *work order* made on or before the contract date and if this contract is completed the purchaser must comply with any other *work order*.
- 11.2 If the purchaser complies with a *work order*, and this contract is *rescinded* or *terminated*, the vendor must pay the expense of compliance to the purchaser.
- 12 Certificates and inspections**
- The vendor must do everything reasonable to enable the purchaser, subject to the rights of any tenant –
- 12.1 to have the *property* inspected to obtain any certificate or report reasonably required;
- 12.2 to apply (if necessary in the name of the vendor) for –
- 12.2.1 any certificate that can be given in respect of the *property* under *legislation*; or
- 12.2.2 a copy of any approval, certificate, consent, direction, notice or order in respect of the *property* given under *legislation*, even if given after the contract date; and
- 12.3 to make 1 inspection of the *property* in the 3 days before a time appointed for completion.
- 13 Goods and services tax (GST)**
- 13.1 Terms used in this clause which are not defined elsewhere in this contract and have a defined meaning in the *GST Act* have the same meaning in this clause.
- 13.2 *Normally*, if a *party* must pay the price or any other amount to the other *party* under this contract, GST is not to be added to the price or amount.
- 13.3 If under this contract a *party* must make an adjustment or payment for an expense of another party or pay an expense payable by or to a third party (for example, under clauses 14 or 20.7) –
- 13.3.1 the *party* must adjust or pay on completion any GST added to or included in the expense; but
- 13.3.2 the amount of the expense must be reduced to the extent the party receiving the adjustment or payment (or the representative member of a GST group of which that party is a member) is entitled to an input tax credit for the expense; and
- 13.3.3 if the adjustment or payment under this contract is consideration for a taxable supply, an amount for GST must be added at the *GST rate*.
- 13.4 If this contract says this sale is the supply of a going concern –
- 13.4.1 the *parties* agree the supply of the *property* is a supply of a going concern;
- 13.4.2 the vendor must, between the contract date and completion, carry on the enterprise conducted on the land in a proper and business-like way;
- 13.4.3 if the purchaser is not registered by the date for completion, the *parties* must complete and the purchaser must pay on completion, in addition to the price, an amount being the price multiplied by the *GST rate* ("the retention sum"). The retention sum is to be held by the *depositholder* and dealt with as follows –
- if *within* 3 months of completion the purchaser *serves* a letter from the Australian Taxation Office stating the purchaser is registered with a date of effect of registration on or before completion, the *depositholder* is to pay the retention sum to the purchaser; but
 - if the purchaser does not *serve* that letter *within* 3 months of completion, the *depositholder* is to pay the retention sum to the vendor; and
- 13.4.4 if the vendor, despite clause 13.4.1, *serves* a letter from the Australian Taxation Office stating the vendor has to pay GST on the supply, the purchaser must pay to the vendor on demand the amount of GST assessed.
- 13.5 *Normally*, the vendor promises the margin scheme will not apply to the supply of the *property*.
- 13.6 If this contract says the margin scheme is to apply in making the taxable supply, the *parties* agree that the margin scheme is to apply to the sale of the *property*.
- 13.7 If this contract says the sale is not a taxable supply –
- 13.7.1 the purchaser promises that the *property* will not be used and represents that the purchaser does not intend the *property* (or any part of the *property*) to be used in a way that could make the sale a taxable supply to any extent; and
- 13.7.2 the purchaser must pay the vendor on completion in addition to the price an amount calculated by multiplying the price by the *GST rate* if this sale is a taxable supply to any extent because of –
- a breach of clause 13.7.1; or
 - something else known to the purchaser but not the vendor.
- 13.8 If this contract says this sale is a taxable supply in full and does not say the margin scheme applies to the *property*, the vendor must pay the purchaser on completion an amount of one-eleventh of the price if –

- 13.8.1 this sale is not a taxable supply in full; or
- 13.8.2 the margin scheme applies to the *property* (or any part of the *property*).
- 13.9 If this contract says this sale is a taxable supply to an extent –
- 13.9.1 clause 13.7.1 does not apply to any part of the *property* which is identified as being a taxable supply; and
- 13.9.2 the payments mentioned in clauses 13.7 and 13.8 are to be recalculated by multiplying the relevant payment by the proportion of the price which represents the value of that part of the *property* to which the clause applies (the proportion to be expressed as a number between 0 and 1). Any evidence of value must be obtained at the expense of the vendor.
- 13.10 *Normally*, on completion the vendor must give the recipient of the supply a tax invoice for any taxable supply by the vendor by or under this contract.
- 13.11 The vendor does not have to give the purchaser a tax invoice if the margin scheme applies to a taxable supply.
- 13.12 If the vendor is liable for GST on rents or profits due to issuing an invoice or receiving consideration before completion, any adjustment of those amounts must exclude an amount equal to the vendor's GST liability.
- 13.13 If the purchaser must make a *GSTRW payment* the purchaser must –
- 13.13.1 at least 5 days before the date for completion, *serve* evidence of submission of a *GSTRW payment* notification form to the Australian Taxation Office by the purchaser or, if a direction under clause 4.3 has been *served*, by the transferee named in the transfer *served* with that direction;
- 13.13.2 produce on completion a *settlement cheque* for the *GSTRW payment* payable to the Deputy Commissioner of Taxation;
- 13.13.3 forward the *settlement cheque* to the payee immediately after completion; and
- 13.13.4 *serve* evidence of receipt of payment of the *GSTRW payment* and a copy of the settlement date confirmation form submitted to the Australian Taxation Office.

14 Adjustments

- 14.1 *Normally*, the vendor is entitled to the rents and profits and will be liable for all rates, water, sewerage and drainage service and usage charges, land tax, levies and all other periodic outgoings up to and including the *adjustment date* after which the purchaser will be entitled and liable.
- 14.2 The *parties* must make any necessary adjustment on completion.
- 14.3 If an amount that is adjustable under this contract has been reduced under *legislation*, the *parties* must on completion adjust the reduced amount.
- 14.4 The *parties* must not adjust surcharge land tax (as defined in the Land Tax Act 1956) but must adjust any other land tax for the year current at the *adjustment date* –
- 14.4.1 only if land tax has been paid or is payable for the year (whether by the vendor or by a predecessor in title) and this contract says that land tax is adjustable;
- 14.4.2 by adjusting the amount that would have been payable if at the start of the year –
- the person who owned the land owned no other land;
 - the land was not subject to a special trust or owned by a non-concessional company; and
 - if the land (or part of it) had no separate taxable value, by calculating its separate taxable value on a proportional area basis.
- 14.5 If any other amount that is adjustable under this contract relates partly to the land and partly to other land, the *parties* must adjust it on a proportional area basis.
- 14.6 *Normally*, the vendor can direct the purchaser to produce a *settlement cheque* on completion to pay an amount adjustable under this contract and if so –
- 14.6.1 the amount is to be treated as if it were paid; and
- 14.6.2 the *cheque* must be forwarded to the payee immediately after completion (by the purchaser if the *cheque* relates only to the *property* or by the vendor in any other case).
- 14.7 If on completion the last bill for a water, sewerage or drainage usage charge is for a period ending before the *adjustment date*, the vendor is liable for an amount calculated by dividing the bill by the number of days in the period then multiplying by the number of unbilled days up to and including the *adjustment date*.
- 14.8 The vendor is liable for any amount recoverable for work started on or before the contract date on the *property* or any adjoining footpath or road.

15 Date for completion

The *parties* must complete by the date for completion and, if they do not, a *party* can *serve* a notice to complete if that *party* is otherwise entitled to do so.

16 Completion

• Vendor

- 16.1 On completion the vendor must give the purchaser any *document of title* that relates only to the *property*.
- 16.2 If on completion the vendor has possession or control of a *document of title* that relates also to other property, the vendor must produce it as and where necessary.
- 16.3 *Normally*, on completion the vendor must cause the legal title to the *property* (being an estate in fee simple) to pass to the purchaser free of any mortgage or other interest, subject to any necessary registration.
- 16.4 The legal title to the *property* does not pass before completion.

- 16.5 If the vendor gives the purchaser a document (other than the transfer) that needs to be lodged for registration, the vendor must pay the lodgment fee to the purchaser.
- 16.6 If a *party serves* a land tax certificate showing a charge on any of the land, by completion the vendor must do all things and pay all money required so that the charge is no longer effective against the land.
- **Purchaser**
- 16.7 On completion the purchaser must pay to the vendor, by cash (up to \$2,000) or *settlement cheque* –
- 16.7.1 the price less any:
- deposit paid;
 - *FRCGW remittance* payable;
 - *GSTRW payment*; and
 - amount payable by the vendor to the purchaser under this contract; and
- 16.7.2 any other amount payable by the purchaser under this contract.
- 16.8 If the vendor requires more than 5 *settlement cheques*, the vendor must pay \$10 for each extra *cheque*.
- 16.9 If any of the deposit is not covered by a bond or guarantee, on completion the purchaser must give the vendor an order signed by the purchaser authorising the *depositholder* to account to the vendor for the deposit.
- 16.10 On completion the deposit belongs to the vendor.
- **Place for completion**
- 16.11 *Normally*, the *parties* must complete at the completion address, which is –
- 16.11.1 if a special completion address is stated in this contract - that address; or
- 16.11.2 if none is stated, but a first mortgagee is disclosed in this contract and the mortgagee would usually discharge the mortgage at a particular place - that place; or
- 16.11.3 in any other case - the vendor's *solicitor's* address stated in this contract.
- 16.12 The vendor by reasonable notice can require completion at another place, if it is in NSW, but the vendor must pay the purchaser's additional expenses, including any agency or mortgagee fee.
- 16.13 If the purchaser requests completion at a place that is not the completion address, and the vendor agrees, the purchaser must pay the vendor's additional expenses, including any agency or mortgagee fee.
- 17 Possession**
- 17.1 *Normally*, the vendor must give the purchaser vacant possession of the *property* on completion.
- 17.2 The vendor does not have to give vacant possession if –
- 17.2.1 this contract says that the sale is subject to existing tenancies; and
- 17.2.2 the contract discloses the provisions of the tenancy (for example, by attaching a copy of the lease and any relevant memorandum or variation).
- 17.3 *Normally*, the purchaser can claim compensation (before or after completion) or *rescind* if any of the land is affected by a protected tenancy (a tenancy affected by Schedule 2, Part 7 of the Residential Tenancies Act 2010).
- 18 Possession before completion**
- 18.1 This clause applies only if the vendor gives the purchaser possession of the *property* before completion.
- 18.2 The purchaser must not before completion –
- 18.2.1 let or part with possession of any of the *property*;
- 18.2.2 make any change or structural alteration or addition to the *property*; or
- 18.2.3 contravene any agreement between the *parties* or any direction, document, *legislation*, notice or order affecting the *property*.
- 18.3 The purchaser must until completion –
- 18.3.1 keep the *property* in good condition and repair having regard to its condition at the giving of possession; and
- 18.3.2 allow the vendor or the vendor's authorised representative to enter and inspect it at all reasonable times.
- 18.4 The risk as to damage to the *property* passes to the purchaser immediately after the purchaser enters into possession.
- 18.5 If the purchaser does not comply with this clause, then without affecting any other right of the vendor –
- 18.5.1 the vendor can before completion, without notice, remedy the non-compliance; and
- 18.5.2 if the vendor pays the expense of doing this, the purchaser must pay it to the vendor with interest at the rate prescribed under s101 Civil Procedure Act 2005.
- 18.6 If this contract is *rescinded* or *terminated* the purchaser must immediately vacate the *property*.
- 18.7 If the *parties* or their *solicitors* on their behalf do not agree in writing to a fee or rent, none is payable.
- 19 Rescission of contract**
- 19.1 If this contract expressly gives a *party* a right to *rescind*, the *party* can exercise the right –
- 19.1.1 only by *-serving* a notice before completion; and
- 19.1.2 in spite of any making of a claim or *requisition*, any attempt to satisfy a claim or *requisition*, any arbitration, litigation, mediation or negotiation or any giving or taking of possession.
- 19.2 *Normally*, if a *party* exercises a right to *rescind* expressly given by this contract or any *legislation* –
- 19.2.1 the deposit and any other money paid by the purchaser under this contract must be refunded;
- 19.2.2 a *party* can claim for a reasonable adjustment if the purchaser has been in possession;
- 19.2.3 a *party* can claim for damages, costs or expenses arising out of a breach of this contract; and
- 19.2.4 a *party* will not otherwise be liable to pay the other *party* any damages, costs or expenses.

20 Miscellaneous

- 20.1 The *parties* acknowledge that anything stated in this contract to be attached was attached to this contract by the vendor before the purchaser signed it and is part of this contract.
- 20.2 Anything attached to this contract is part of this contract.
- 20.3 An area, bearing or dimension in this contract is only approximate.
- 20.4 If a *party* consists of 2 or more persons, this contract benefits and binds them separately and together.
- 20.5 A *party's solicitor* can receive any amount payable to the *party* under this contract or direct in writing that it is to be paid to another person.
- 20.6 A document under or relating to this contract is –
- 20.6.1 signed by a *party* if it is signed by the *party* or the *party's solicitor* (apart from a direction under clause 4.3);
- 20.6.2 *served* if it is *served* by the *party* or the *party's solicitor*;
- 20.6.3 *served* if it is *served* on the *party's solicitor*, even if the *party* has died or any of them has died;
- 20.6.4 *served* if it is *served* in any manner provided in s170 of the Conveyancing Act 1919;
- 20.6.5 *served* if it is sent by email or fax to the *party's solicitor*, unless in either case it is not received;
- 20.6.6 *served* on a person if it (or a copy of it) comes into the possession of the person; and
- 20.6.7 *served* at the earliest time it is *served*, if it is *served* more than once.
- 20.7 An obligation to pay an expense of another *party* of doing something is an obligation to pay –
- 20.7.1 if the *party* does the thing personally - the reasonable cost of getting someone else to do it; or
- 20.7.2 if the *party* pays someone else to do the thing - the amount paid, to the extent it is reasonable.
- 20.8 Rights under clauses 11, 13, 14, 17, 24, 30 and 31 continue after completion, whether or not other rights continue.
- 20.9 The vendor does not promise, represent or state that the purchaser has any cooling off rights.
- 20.10 The vendor does not promise, represent or state that any attached survey report is accurate or current.
- 20.11 A reference to any *legislation* (including any percentage or rate specified in *legislation*) is also a reference to any corresponding later *legislation*.
- 20.12 Each *party* must do whatever is necessary after completion to carry out the *party's* obligations under this contract.
- 20.13 Neither taking possession nor *servicing* a transfer of itself implies acceptance of the *property* or the title.
- 20.14 The details and information provided in this contract (for example, on pages 1 - 3) are, to the extent of each *party's* knowledge, true, and are part of this contract.
- 20.15 Where this contract provides for choices, a choice in BLOCK CAPITALS applies unless a different choice is marked.

21 Time limits in these provisions

- 21.1 If the time for something to be done or to happen is not stated in these provisions, it is a reasonable time.
- 21.2 If there are conflicting times for something to be done or to happen, the latest of those times applies.
- 21.3 The time for one thing to be done or to happen does not extend the time for another thing to be done or to happen.
- 21.4 If the time for something to be done or to happen is the 29th, 30th or 31st day of a month, and the day does not exist, the time is instead the last day of the month.
- 21.5 If the time for something to be done or to happen is a day that is not a *business day*, the time is extended to the next *business day*, except in the case of clauses 2 and 3.2.
- 21.6 *Normally*, the time by which something must be done is fixed but not essential.

22 Foreign Acquisitions and Takeovers Act 1975

- 22.1 The purchaser promises that the Commonwealth Treasurer cannot prohibit and has not prohibited the transfer under the Foreign Acquisitions and Takeovers Act 1975.
- 22.2 This promise is essential and a breach of it entitles the vendor to *terminate*.

23 Strata or community title**• Definitions and modifications**

- 23.1 This clause applies only if the land (or part of it) is a lot in a strata, neighbourhood, precinct or community scheme (or on completion is to be a lot in a scheme of that kind).
- 23.2 In this contract –
- 23.2.1 'change', in relation to a scheme, means –
- a registered or registrable change from by-laws set out in this contract;
 - a change from a development or management contract or statement set out in this contract; or
 - a change in the boundaries of common property;
- 23.2.2 'common property' includes association property for the scheme or any higher scheme;
- 23.2.3 'contribution' includes an amount payable under a by-law;
- 23.2.4 'information certificate' includes a certificate under s184 Strata Schemes Management Act 2015 and s26 Community Land Management Act 1989;
- 23.2.5 'information notice' includes a strata information notice under s22 Strata Schemes Management Act 2015 and a notice under s47 Community Land Management Act 1989;

- 23.2.6 'normal expenses', in relation to an owners corporation for a scheme, means normal operating expenses usually payable from the administrative fund of an owners corporation for a scheme of the same kind;
- 23.2.7 'owners corporation' means the owners corporation or the association for the scheme or any higher scheme;
- 23.2.8 'the *property*' includes any interest in common property for the scheme associated with the lot; and
- 23.2.9 'special expenses', in relation to an owners corporation, means its actual, contingent or expected expenses, except to the extent they are –
- normal expenses;
 - due to fair wear and tear;
 - disclosed in this contract; or
 - covered by moneys held in the capital works fund.
- 23.3 Clauses 11, 14.8 and 18.4 do not apply to an obligation of the owners corporation, or to property insurable by it.
- 23.4 Clauses 14.4.2 and 14.5 apply but on a unit entitlement basis instead of an area basis.
- **Adjustments and liability for expenses**
- 23.5 The *parties* must adjust under clause 14.1 –
- 23.5.1 a regular periodic contribution;
- 23.5.2 a contribution which is not a regular periodic contribution but is disclosed in this contract; and
- 23.5.3 on a unit entitlement basis, any amount paid by the vendor for a normal expense of the owners corporation to the extent the owners corporation has not paid the amount to the vendor.
- 23.6 If a contribution is not a regular periodic contribution and is not disclosed in this contract –
- 23.6.1 the vendor is liable for it if it was determined on or before the contract date, even if it is payable by instalments; and
- 23.6.2 the purchaser is liable for all contributions determined after the contract date.
- 23.7 The vendor must pay or allow to the purchaser on completion the amount of any unpaid contributions for which the vendor is liable under clause 23.6.1.
- 23.8 *Normally*, the purchaser cannot make a claim or *requisition* or *rescind* or *terminate* in respect of –
- 23.8.1 an existing or future actual, contingent or expected expense of the owners corporation;
- 23.8.2 a proportional unit entitlement of the lot or a relevant lot or former lot, apart from a claim under clause 6; or
- 23.8.3 a past or future change in the scheme or a higher scheme.
- 23.9 However, the purchaser can *rescind* if –
- 23.9.1 the special expenses of the owners corporation at the later of the contract date and the creation of the owners corporation when calculated on a unit entitlement basis (and, if more than one lot or a higher scheme is involved, added together), less any contribution paid by the vendor, are more than 1% of the price;
- 23.9.2 in the case of the lot or a relevant lot or former lot in a higher scheme, a proportional unit entitlement for the lot is disclosed in this contract but the lot has a different proportional unit entitlement at the contract date or at any time before completion;
- 23.9.3 a change before the contract date or before completion in the scheme or a higher scheme materially prejudices the purchaser and is not disclosed in this contract; or
- 23.9.4 a resolution is passed by the owners corporation before the contract date or before completion to give to the owners in the scheme for their consideration a strata renewal plan that has not lapsed at the contract date and there is not attached to this contract a strata renewal proposal or the strata renewal plan.
- **Notices, certificates and inspections**
- 23.10 The purchaser must give the vendor 2 copies of an information notice addressed to the owners corporation and signed by the purchaser.
- 23.11 The vendor must complete and sign 1 copy of the notice and give it to the purchaser on completion.
- 23.12 Each *party* can sign and give the notice as agent for the other.
- 23.13 The vendor must *serve* an information certificate issued after the contract date in relation to the lot, the scheme or any higher scheme at least 7 days before the date for completion.
- 23.14 The purchaser does not have to complete earlier than 7 days after *service* of the certificate and clause 21.3 does not apply to this provision. On completion the purchaser must pay the vendor the prescribed fee for the certificate.
- 23.15 The vendor authorises the purchaser to apply for the purchaser's own certificate.
- 23.16 The vendor authorises the purchaser to apply for and make an inspection of any record or other document in the custody or control of the owners corporation or relating to the scheme or any higher scheme.
- **Meetings of the owners corporation**
- 23.17 If a general meeting of the owners corporation is convened before completion –
- 23.17.1 if the vendor receives notice of it, the vendor must immediately notify the purchaser of it; and
- 23.17.2 after the expiry of any cooling off period, the purchaser can require the vendor to appoint the purchaser (or the purchaser's nominee) to exercise any voting rights of the vendor in respect of the lot at the meeting.

24 Tenancies

- 24.1 If a tenant has not made a payment for a period preceding or current at the *adjustment date* –
- 24.1.1 for the purposes of clause 14.2, the amount is to be treated as if it were paid; and
- 24.1.2 the purchaser assigns the debt to the vendor on completion and will if required give a further assignment at the vendor's expense.
- 24.2 If a tenant has paid in advance of the *adjustment date* any periodic payment in addition to rent, it must be adjusted as if it were rent for the period to which it relates.
- 24.3 If the *property* is to be subject to a tenancy on completion or is subject to a tenancy on completion –
- 24.3.1 the vendor authorises the purchaser to have any accounting records relating to the tenancy inspected and audited and to have any other document relating to the tenancy inspected;
- 24.3.2 the vendor must *serve* any information about the tenancy reasonably requested by the purchaser before or after completion; and
- 24.3.3 *normally*, the purchaser can claim compensation (before or after completion) if –
- a disclosure statement required by the Retail Leases Act 1994 was not given when required;
 - such a statement contained information that was materially false or misleading;
 - a provision of the lease is not enforceable because of a non-disclosure in such a statement; or
 - the lease was entered into in contravention of the Retail Leases Act 1994.
- 24.4 If the *property* is subject to a tenancy on completion –
- 24.4.1 the vendor must allow or transfer –
- any remaining bond money or any other security against the tenant's default (to the extent the security is transferable);
 - any money in a fund established under the lease for a purpose and compensation for any money in the fund or interest earned by the fund that has been applied for any other purpose; and
 - any money paid by the tenant for a purpose that has not been applied for that purpose and compensation for any of the money that has been applied for any other purpose;
- 24.4.2 if the security is not transferable, each *party* must do everything reasonable to cause a replacement security to issue for the benefit of the purchaser and the vendor must hold the original security on trust for the benefit of the purchaser until the replacement security issues;
- 24.4.3 the vendor must give to the purchaser –
- a proper notice of the transfer (an attornment notice) addressed to the tenant;
 - any certificate given under the Retail Leases Act 1994 in relation to the tenancy;
 - a copy of any disclosure statement given under the Retail Leases Act 1994;
 - a copy of any document served on the tenant under the lease and written details of its service, if the document concerns the rights of the landlord or the tenant after completion; and
 - any document served by the tenant under the lease and written details of its service, if the document concerns the rights of the landlord or the tenant after completion;
- 24.4.4 the vendor must comply with any obligation to the tenant under the lease, to the extent it is to be complied with by completion; and
- 24.4.5 the purchaser must comply with any obligation to the tenant under the lease, to the extent that the obligation is disclosed in this contract and is to be complied with after completion.

25 Qualified title, limited title and old system title

- 25.1 This clause applies only if the land (or part of it) –
- 25.1.1 is under qualified, limited or old system title; or
- 25.1.2 on completion is to be under one of those titles.
- 25.2 The vendor must *serve* a proper abstract of title *within 7 days* after the contract date.
- 25.3 If an abstract of title or part of an abstract of title is attached to this contract or has been lent by the vendor to the purchaser before the contract date, the abstract or part is *served* on the contract date.
- 25.4 An abstract of title can be or include a list of documents, events and facts arranged (apart from a will or codicil) in date order, if the list in respect of each document –
- 25.4.1 shows its date, general nature, names of parties and any registration number; and
- 25.4.2 has attached a legible photocopy of it or of an official or registration copy of it.
- 25.5 An abstract of title –
- 25.5.1 must start with a good root of title (if the good root of title must be at least 30 years old, this means 30 years old at the contract date);
- 25.5.2 in the case of a leasehold interest, must include an abstract of the lease and any higher lease;
- 25.5.3 *normally*, need not include a Crown grant; and
- 25.5.4 need not include anything evidenced by the Register kept under the Real Property Act 1900.
- 25.6 In the case of land under old system title –
- 25.6.1 in this contract 'transfer' means conveyance;
- 25.6.2 the purchaser does not have to *serve* the form of transfer until after the vendor has *served* a proper abstract of title; and
- 25.6.3 each vendor must give proper covenants for title as regards that vendor's interest.
- 25.7 In the case of land under limited title but not under qualified title –

- 25.7.1 *normally*, the abstract of title need not include any document which does not show the location, area or dimensions of the land (for example, by including a metes and bounds description or a plan of the land);
- 25.7.2 clause 25.7.1 does not apply to a document which is the good root of title; and
- 25.7.3 the vendor does not have to provide an abstract if this contract contains a delimitation plan (whether in registrable form or not).
- 25.8 The vendor must give a proper covenant to produce where relevant.
- 25.9 The vendor does not have to produce or covenant to produce a document that is not in the possession of the vendor or a mortgagee.
- 25.10 If the vendor is unable to produce an original document in the chain of title, the purchaser will accept a photocopy from the Registrar-General of the registration copy of that document.
- 26 Crown purchase money**
- 26.1 This clause applies only if purchase money is payable to the Crown, whether or not due for payment.
- 26.2 The vendor is liable for the money, except to the extent this contract says the purchaser is liable for it.
- 26.3 To the extent the vendor is liable for it, the vendor is liable for any interest until completion.
- 26.4 To the extent the purchaser is liable for it, the *parties* must adjust any interest under clause 14.1.
- 27 Consent to transfer**
- 27.1 This clause applies only if the land (or part of it) cannot be transferred without consent under *legislation* or a *planning agreement*.
- 27.2 The purchaser must properly complete and then *serve* the purchaser's part of an application for consent to transfer of the land (or part of it) *within 7 days* after the contract date.
- 27.3 The vendor must apply for consent *within 7 days* after *service* of the purchaser's part.
- 27.4 If consent is refused, either *party* can *rescind*.
- 27.5 If consent is given subject to one or more conditions that will substantially disadvantage a *party*, then that *party* can *rescind within 7 days* after receipt by or *service* upon the *party* of written notice of the conditions.
- 27.6 If consent is not given or refused –
- 27.6.1 *within 42 days* after the purchaser *serves* the purchaser's part of the application, the purchaser can *rescind*; or
- 27.6.2 *within 30 days* after the application is made, either *party* can *rescind*.
- 27.7 Each period in clause 27.6 becomes 90 days if the land (or part of it) is –
- 27.7.1 under a *planning agreement*, or
- 27.7.2 in the Western Division.
- 27.8 If the land (or part of it) is described as a lot in an unregistered plan, each time in clause 27.6 becomes the later of the time and 35 days after creation of a separate folio for the lot.
- 27.9 The date for completion becomes the later of the date for completion and 14 days after *service* of the notice granting consent to transfer.
- 28 Unregistered plan**
- 28.1 This clause applies only if some of the land is described as a lot in an unregistered plan.
- 28.2 The vendor must do everything reasonable to have the plan registered *within 6 months* after the contract date, with or without any minor alteration to the plan or any document to be lodged with the plan validly required or made under *legislation*.
- 28.3 If the plan is not registered *within* that time and in that manner –
- 28.3.1 the purchaser can *rescind*; and
- 28.3.2 the vendor can *rescind*, but only if the vendor has complied with clause 28.2 and with any *legislation* governing the rescission.
- 28.4 Either *party* can *serve* notice of the registration of the plan and every relevant lot and plan number.
- 28.5 The date for completion becomes the later of the date for completion and 21 days after *service* of the notice.
- 28.6 Clauses 28.2 and 28.3 apply to another plan that is to be registered before the plan is registered.
- 29 Conditional contract**
- 29.1 This clause applies only if a provision says this contract or completion is conditional on an event.
- 29.2 If the time for the event to happen is not stated, the time is 42 days after the contract date.
- 29.3 If this contract says the provision is for the benefit of a *party*, then it benefits only that *party*.
- 29.4 If anything is necessary to make the event happen, each *party* must do whatever is reasonably necessary to cause the event to happen.
- 29.5 A *party* can *rescind* under this clause only if the *party* has substantially complied with clause 29.4.
- 29.6 If the event involves an approval and the approval is given subject to a condition that will substantially disadvantage a *party* who has the benefit of the provision, the *party* can *rescind within 7 days* after either *party* *serves* notice of the condition.
- 29.7 If the *parties* can lawfully complete without the event happening –
- 29.7.1 if the event does not happen *within* the time for it to happen, a *party* who has the benefit of the provision can *rescind within 7 days* after the end of that time;
- 29.7.2 if the event involves an approval and an application for the approval is refused, a *party* who has the benefit of the provision can *rescind within 7 days* after either *party* *serves* notice of the refusal; and

- 29.7.3 the date for completion becomes the later of the date for completion and 21 days after the earliest of –
- either *party serving* notice of the event happening;
 - every *party* who has the benefit of the provision *serving* notice waiving the provision; or
 - the end of the time for the event to happen.
- 29.8 If the *parties* cannot lawfully complete without the event happening –
- 29.8.1 if the event does not happen *within* the time for it to happen, either *party* can *rescind*;
- 29.8.2 if the event involves an approval and an application for the approval is refused, either *party* can *rescind*;
- 29.8.3 the date for completion becomes the later of the date for completion and 21 days after either *party* *serves* notice of the event happening.
- 29.9 A *party* cannot *rescind* under clauses 29.7 or 29.8 after the event happens.
- 30 Electronic transaction**
- 30.1 This *Conveyancing Transaction* is to be conducted as an *electronic transaction* if –
- 30.1.1 this contract says that it is an *electronic transaction*;
- 30.1.2 the *parties* otherwise agree that it is to be conducted as an *electronic transaction*; or
- 30.1.3 the *conveyancing rules* require it to be conducted as an *electronic transaction*.
- 30.2 However, this *Conveyancing Transaction* is not to be conducted as an *electronic transaction* –
- 30.2.1 if the land is not *electronically tradeable* or the transfer is not eligible to be lodged electronically; or
- 30.2.2 if, at any time after the *effective date*, but at least 14 days before the date for completion, a *party* *serves* a notice stating a valid reason why it cannot be conducted as an *electronic transaction*.
- 30.3 If, because of clause 30.2.2, this *Conveyancing Transaction* is not to be conducted as an *electronic transaction* –
- 30.3.1 each *party* must –
- bear equally any disbursements or fees; and
 - otherwise bear that *party's* own costs;
- incurred because this *Conveyancing Transaction* was to be conducted as an *electronic transaction*; and
- 30.3.2 if a *party* has paid all of a disbursement or fee which, by reason of this clause, is to be borne equally by the *parties*, that amount must be adjusted under clause 14.2.
- 30.4 If this *Conveyancing Transaction* is to be conducted as an *electronic transaction* –
- 30.4.1 to the extent that any other provision of this contract is inconsistent with this clause, the provisions of this clause prevail;
- 30.4.2 *normally*, words and phrases used in this clause 30 (italicised and in Title Case, such as *Electronic Workspace* and *Lodgment Case*) have the same meaning which they have in the *participation rules*;
- 30.4.3 the *parties* must conduct the *electronic transaction* –
- in accordance with the *participation rules* and the *ECNL*; and
 - using the nominated *ELN*, unless the *parties* otherwise agree;
- 30.4.4 a *party* must pay the fees and charges payable by that *party* to the *ELNO* and the *Land Registry* as a result of this transaction being an *electronic transaction*;
- 30.4.5 any communication from one *party* to another *party* in the *Electronic Workspace* made –
- after the *effective date*; and
 - before the receipt of a notice given under clause 30.2.2;
- is taken to have been received by that *party* at the time determined by s13A of the *Electronic Transactions Act 2000*; and
- 30.4.6 a document which is an *electronic document* is *served* as soon as it is first *Digitally Signed* in the *Electronic Workspace* on behalf of the *party* required to *serve* it.
- 30.5 *Normally*, the vendor must *within 7 days* of the *effective date* –
- 30.5.1 create an *Electronic Workspace*;
- 30.5.2 *populate* the *Electronic Workspace* with *title data*, the date for completion and, if applicable, *mortgagee details*; and
- 30.5.3 invite the purchaser and any *discharging mortgagee* to the *Electronic Workspace*.
- 30.6 If the vendor has not created an *Electronic Workspace* in accordance with clause 30.5, the purchaser may create an *Electronic Workspace*. If the purchaser creates the *Electronic Workspace* the purchaser must –
- 30.6.1 *populate* the *Electronic Workspace* with *title data*;
- 30.6.2 create and *populate* an *electronic transfer*;
- 30.6.3 *populate* the *Electronic Workspace* with the date for completion and a nominated *completion time*; and
- 30.6.4 invite the vendor and any *incoming mortgagee* to join the *Electronic Workspace*.
- 30.7 *Normally*, *within 7 days* of receiving an invitation from the vendor to join the *Electronic Workspace*, the purchaser must –
- 30.7.1 join the *Electronic Workspace*;
- 30.7.2 create and *populate* an *electronic transfer*;
- 30.7.3 invite any *incoming mortgagee* to join the *Electronic Workspace*; and
- 30.7.4 *populate* the *Electronic Workspace* with a nominated *completion time*.

- 30.8 If the purchaser has created the *Electronic Workspace* the vendor must *within* 7 days of being invited to the *Electronic Workspace* –
- 30.8.1 join the *Electronic Workspace*;
- 30.8.2 *populate* the *Electronic Workspace* with *mortgagee details*, if applicable; and
- 30.8.3 invite any *discharging mortgagee* to join the *Electronic Workspace*.
- 30.9 To complete the financial settlement schedule in the *Electronic Workspace* –
- 30.9.1 the purchaser must provide the vendor with *adjustment figures* at least 2 *business days* before the date for completion;
- 30.9.2 the vendor must confirm the *adjustment figures* at least 1 *business day* before the date for completion; and
- 30.9.3 if the purchaser must make a *GSTRW payment* or an *FRCGW remittance*, the purchaser must *populate* the *Electronic Workspace* with the payment details for the *GSTRW payment* or *FRCGW remittance* payable to the Deputy Commissioner of Taxation at least 2 *business days* before the date for completion.
- 30.10 Before completion, the *parties* must ensure that –
- 30.10.1 all *electronic documents* which a *party* must *Digitally Sign* to complete the *electronic transaction* are *populated* and *Digitally Signed*;
- 30.10.2 all certifications required by the *ECNL* are properly given; and
- 30.10.3 they do everything else in the *Electronic Workspace* which that *party* must do to enable the *electronic transaction* to proceed to completion.
- 30.11 If completion takes place in the *Electronic Workspace* –
- 30.11.1 payment electronically on completion of the price in accordance with clause 16.7 is taken to be payment by a single *settlement cheque*;
- 30.11.2 the completion address in clause 16.11 is the *Electronic Workspace*; and
- 30.11.3 clauses 13.13.2 to 13.13.4, 16.8, 16.12, 16.13 and 31.2.2 to 31.2.4 do not apply.
- 30.12 If the computer systems of any of the *Land Registry*, the *ELNO* or the Reserve Bank of Australia are inoperative for any reason at the *completion time* agreed by the *parties*, a failure to complete this contract for that reason is not a default under this contract on the part of either *party*.
- 30.13 If the computer systems of the *Land Registry* are inoperative for any reason at the *completion time* agreed by the *parties*, and the *parties* choose that financial settlement is to occur despite this, then on financial settlement occurring –
- 30.13.1 all *electronic documents Digitally Signed* by the vendor, the *certificate of title* and any discharge of mortgage, withdrawal of caveat or other *electronic document* forming part of the *Lodgment Case* for the *electronic transaction* shall be taken to have been unconditionally and irrevocably delivered to the purchaser or the purchaser's mortgagee at the time of financial settlement together with the right to deal with the land comprised in the *certificate of title*; and
- 30.13.2 the vendor shall be taken to have no legal or equitable interest in the *property*.
- 30.14 A *party* who holds a *certificate of title* must act in accordance with any *Prescribed Requirement* in relation to the *certificate of title* but if there is no *Prescribed Requirement*, the vendor must *serve* the *certificate of title* after completion.
- 30.15 If the *parties* do not agree about the delivery before completion of one or more documents or things that cannot be delivered through the *Electronic Workspace*, the *party* required to deliver the documents or things –
- 30.15.1 holds them on completion in escrow for the benefit of; and
- 30.15.2 must immediately after completion deliver the documents or things to, or as directed by; the *party* entitled to them.
- 30.16 In this clause 30, these terms (in any form) mean –
- adjustment figures* details of the adjustments to be made to the price under clause 14;
- certificate of title* the paper duplicate of the folio of the register for the land which exists immediately prior to completion and, if more than one, refers to each such paper duplicate;
- completion time* the time of day on the date for completion when the *electronic transaction* is to be settled;
- conveyancing rules* the rules made under s12E of the Real Property Act 1900;
- discharging mortgagee* any discharging mortgagee, chargee, covenant chargee or caveator whose provision of a *Digitally Signed* discharge of mortgage, discharge of charge or withdrawal of caveat is required in order for unencumbered title to the *property* to be transferred to the purchaser;
- ECNL* the Electronic Conveyancing National Law (NSW);
- effective date* the date on which the *Conveyancing Transaction* is agreed to be an *electronic transaction* under clause 30.1.2 or, if clauses 30.1.1 or 30.1.3 apply, the contract date;
- electronic document* a dealing as defined in the Real Property Act 1900 which may be created and *Digitally Signed* in an *Electronic Workspace*;
- electronic transfer* a transfer of land under the Real Property Act 1900 for the *property* to be prepared and *Digitally Signed* in the *Electronic Workspace* established for the purposes of the *parties' Conveyancing Transaction*;

<i>electronic transaction</i>	a <i>Conveyancing Transaction</i> to be conducted for the <i>parties</i> by their legal representatives as <i>Subscribers</i> using an <i>ELN</i> and in accordance with the <i>ECNL</i> and the <i>participation rules</i> ;
<i>electronically tradeable</i>	a land title that is Electronically Tradeable as that term is defined in the <i>conveyancing rules</i> ;
<i>incoming mortgagee</i>	any mortgagee who is to provide finance to the purchaser on the security of the <i>property</i> and to enable the purchaser to pay the whole or part of the price;
<i>mortgagee details</i>	the details which a <i>party</i> to the <i>electronic transaction</i> must provide about any <i>discharging mortgagee</i> of the <i>property</i> as at completion;
<i>participation rules</i>	the participation rules as determined by the <i>ECNL</i> ;
<i>populate</i>	to complete data fields in the <i>Electronic Workspace</i> ; and
<i>title data</i>	the details of the title to the <i>property</i> made available to the <i>Electronic Workspace</i> by the <i>Land Registry</i> .

31 Foreign Resident Capital Gains Withholding

- 31.1 This clause applies only if –
- 31.1.1 the sale is not an excluded transaction within the meaning of s14-215 of Schedule 1 to the *TA Act*, and
- 31.1.2 a *clearance certificate* in respect of every vendor is not attached to this contract.
- 31.2 The purchaser must –
- 31.2.1 at least 5 days before the date for completion, *serve* evidence of submission of a purchaser payment notification to the Australian Taxation Office by the purchaser or, if a direction under clause 4.3 has been *served*, by the transferee named in the transfer *served* with that direction;
- 31.2.2 produce on completion a *settlement cheque* for the *FRCGW remittance* payable to the Deputy Commissioner of Taxation;
- 31.2.3 forward the *settlement cheque* to the payee immediately after completion; and
- 31.2.4 *serve* evidence of receipt of payment of the *FRCGW remittance*.
- 31.3 The vendor cannot refuse to complete if the purchaser complies with clauses 31.2.1 and 31.2.2.
- 31.4 If the vendor *serves* any *clearance certificate* or *variation*, the purchaser does not have to complete earlier than 7 days after that *service* and clause 21.3 does not apply to this provision.
- 31.5 If the vendor *serves* in respect of every vendor either a *clearance certificate* or a *variation* to 0.00 percent, clauses 31.2 and 31.3 do not apply.

32 Residential off the plan contract

- 32.1 This clause applies if this contract is an off the plan contract within the meaning of Division 10 of Part 4 of the Conveyancing Act 1919 (the Division).
- 32.2 No provision of this contract has the effect of excluding, modifying or restricting the operation of the Division.
- 32.3 If the purchaser makes a claim for compensation under the terms prescribed by clause 6A of the Conveyancing (Sale of Land) Regulation 2017 –
- 32.3.1 the purchaser cannot make a claim under this contract about the same subject matter, including a claim under clauses 6 or 7; and
- 32.3.2 the claim for compensation is not a claim under this contract.
- 32.4 This clause does not apply to a contract made before the commencement of the amendments to the Division under the Conveyancing Legislation Amendment Act 2018.

Additional Clauses

1. Notice to Complete

- 1.1 If either party fails to complete by the completion date, the other party is entitled to serve a notice to complete at any time (which shall not give less than fourteen (14) days after the date of service of the notice).
- 1.2 The parties agree that fourteen (14) days is a reasonable and sufficient period for a notice to complete making the time for completion essential.
- 1.3 The party serving the notice to complete reserves the right to withdraw the notice at any time and reissue an additional notice at any time.
- 1.4 If the vendor issues a notice to complete, the purchaser shall allow \$220.00 at settlement to the vendor for additional legal fees incurred for this.

2. Delayed Completion

- 2.1 In the event that completion does not take place by the completion date and the vendor is ready, willing, and able to complete, the purchaser shall pay interest on the balance of the purchase price at the rate of 8% per annum calculated daily immediately after the date for completion ending on and including the date of completion.
- 2.2 Additional clause 2.1 is an essential term of this contract and the purchaser cannot require the vendor to complete until the interest payable under additional clause 2.1 is paid.
- 2.3 The interest payable under additional clause 2.1 is a genuine pre-estimate of the vendor's damages as a result of the purchaser's failure to complete on the completion date and is not a penalty.

3. Purchaser Acknowledgements

The Purchaser acknowledges the following:

- 3.1 The purchaser has not entered into this contract as a result of any representation made by the vendor or anyone on behalf of the vendor, other than those stipulated in this contract;
- 3.2 The purchaser has entered into this contract relying on their own enquiries and inspection of the property and the purchaser shall be deemed to have satisfied themselves in this respect;
- 3.3 The property including its improvements, are sold in their present state of condition and repair subject to all latent and patent defects, and subject to any infestation and dilapidation; and

The purchaser shall make no objection, requisition or claim for compensation in respect of any improvements erected thereon or the inclusions which form part of this Contract.

4. Real Estate Agent

The purchaser warrants that they were not introduced to the property or the vendor by any agent or other person who may be entitled to claim commission other than the agent named as 'the vendor's agent' on the front page of this contract. If any agent other than 'the vendor's agent' makes a successful claim for commission against the vendor, the purchaser shall indemnify the vendor against this claim and any costs being a breach of their warranty under this clause. The purchaser shall pay the amount of commission and any costs incurred. This warranty shall not merge on completion of this contract.

5. Solicitor/Conveyancer Amendments

The parties hereby authorise and agree to allow the solicitor/conveyancer acting for them to make written amendments to this contract as agreed between the parties.

6. Requisitions on title

For the purpose of clause 5.1, the attached requisitions to this contract are the only form of requisitions to be answered by the vendor unless further requisitions are raised.

7. Deposit Bond or Bank Guarantee

If the vendor agrees to accept a Deposit Bond or Bank Guarantee, the following applies:

- 7.1 The delivery of the Deposit Bond or Bank Guarantee to the vendor's representative or other person nominated in this contract to hold the deposit, to the extent of the amount guaranteed under the Bond, is deemed to be payment of the deposit in accordance with this contract.
- 7.2 On completion of this contract, the purchaser shall pay to the vendor the amount stipulated under the Bond or Guarantee in addition to all other monies payable under this contract.
- 7.3 In the event that the vendor serves a notice terminating this contract, then to the extent that the amount has not already been paid by the guarantor under the Bond or Guarantee, then the purchaser shall immediately pay the outstanding balance of the deposit to the vendor's representative or other person nominated in this contract.
- 7.4 The vendor agrees that payment of the outstanding balance of the deposit by the guarantor under the Bond or Guarantee shall satisfy the purchaser's obligation for payment under additional clause 7.3.

8. Death, Mental Illness and Bankruptcy

In the event that one or more vendors or one or more purchasers prior to completion:

- 8.1 dies, becomes mentally ill (as defined by section 4 of the *Mental Health Act 2007 (NSW)*) or becomes bankrupt; or
- 8.2 if the vendor or purchaser is a company, and resolve to enter into liquidation or provisional liquidation, enter into any scheme or arrangement with its creditors under Part 5.1 of the *Corporations Act 2001 (Cth)* or have any liquidator, provisional liquidator, receiver, manager, controller or administrator appointed in respect of the party or any of its assets,

then either party may rescind this contract in writing whereupon provisions of clause 19 shall apply.

9. Release of Deposit

The purchaser acknowledges and hereby authorises the vendor's agent or representative to release an amount of the deposit as is required by the vendor for the purpose of payment of a deposit or stamp duty for a purchase of any property in Australia to a real estate agent or solicitor/conveyancer trust account. Provided however that such deposit shall not be further released.

10. Payment of Deposit

10.1 Clause 2 of this Contract is varied as set out in this special condition.

10.2 The deposit is 10% of the purchase price being \$.

10.3 The deposit must be paid by the purchaser in the following way:

(a) \$ before the expiration of the cooling off period of this contract, and this time is essential; and

(b) \$ on the completion date, and this time is essential.

10.4 The vendor may recover from the purchaser as a liquidated debt the deposit or any part of it which has not been paid by the purchaser by the due date.

11. COVID- 19

During the spread of the virus COVID-19, the following conditions apply to both parties:

- a. Should either of the parties to this Contract be required to undertake quarantine or self isolation, that party will notify immediately in writing the other party's conveyancer/solicitor.

- b. The written notification must include the period required for quarantine or self isolation as advised by a medical practitioner or as directed by the most up to date directions by the Federal or NSW State Government and include the reason the self isolation or quarantine is required. Settlement must not take place during this time.
- c. Completion shall take place within fourteen (14) days starting from the date the written notification in this clause was served on the other party.
- d. It is agreed between both parties that no Notice to Complete can be served on the party required to undertake quarantine or self isolation until after this fourteen (14) day period.
- e. If a longer period is required than the fourteen (14) days mentioned in this clause, the party that serves the written notification must provide evidence from a medical practitioner or NSW Health stating the reason for this, or alternatively, it must have been mandated by the government.
- f. The vendor agrees to attempt to disinfect the property to the best of their abilities prior to settlement if they are the party that issue the written notification in this clause.

12. Extension of Completion & Cooling off period Date due to Christmas closure

In the event that the Completion Date falls due during the period 20 December 2022 and 9 January 2023 inclusive, then the Completion Date shall be deemed to be extended to 13 January 2023. Further any such cooling off period that shall fall during such dates will be automatically extended until 13 January 2023 at 5pm.

The parties agree that no notices including a Notice of Rescission or Notice to Complete shall be served during the closure dates or deemed received. This clause shall not merge on completion.

STRATA TITLE (RESIDENTIAL) PROPERTY REQUISITIONS ON TITLE

Vendor **Andrew Stuart Blythin**
Purchaser
Property **3/7 King Street, Ourimbah**
Date

Possession and tenancies

1. Vacant possession of the property must be given on completion unless the Contract provides otherwise.
2. Is anyone in adverse possession of the property or any part of it?
3.
 - (a) What are the nature and provisions of any tenancy or occupancy?
 - (b) If they are in writing, all relevant documentation should be produced, found in order and handed over on completion with notices of attornment.
 - (c) Please specify any existing breaches.
 - (d) All rent should be paid up to or beyond the date of completion.
 - (e) Please provide details of any bond together with the Rental Bond Board's reference number.
 - (f) If any bond money is held by the Rental Bond Board, the appropriate transfer documentation duly signed should be handed over on completion.
4. Is the property affected by a protected tenancy? (A tenancy affected by Parts 2, 3, 4 or 5 of the *Landlord and Tenant (Amendment) Act 1948*.)
5. If the tenancy is subject to the *Residential Tenancies Act 1987*:
 - (a) has either the vendor or any predecessor or the tenant applied to the Residential Tenancies Tribunal for an order?
 - (b) have any orders been made by the Residential Tenancies Tribunal? If so, please provide details.

Title

6. Subject to the Contract, on completion the vendor should be registered as proprietor in fee simple of the property and recorded as the owner of the property on the strata roll, free of all other interests.
 7. On or before completion, any mortgage or caveat must be discharged or withdrawn (as the case may be) or an executed discharge or withdrawal handed over on completion together with a notice under Section 118 of the *Strata Schemes Management Act 1996 (the Act)*.
 8. When and where may the title documents be inspected?
 9. Are the inclusions or fixtures subject to any charge or hiring agreement? If so, details must be given and any indebtedness discharged prior to completion or title transferred unencumbered to the vendor prior to completion.
- Adjustments
10. All outgoings referred to in clause 14.1 of the Contract must be paid up to and including the date of completion.
 11. Is the vendor liable to pay land tax or is the property otherwise charged or liable to be charged with land tax? If so:
 - (a) to what year has a return been made?
 - (b) what is the taxable value of the property for land tax purposes for the current year?

Survey and building

12. Subject to the Contract, survey should be satisfactory and show that the whole of the property and the common property is available, that there are no encroachments by or

- upon the property or the common property and that all improvements comply with local government/planning legislation.
13. Is the vendor in possession of a survey report? If so, please produce a copy for inspection prior to completion. The original should be handed over on completion.
 14. In respect of the property and the common property:
 - (a) Have the provisions of the *Local Government Act*, the *Environmental Planning and Assessment Act 1979* and their regulations been complied with?
 - (b) Is there any matter that could justify the making of an upgrading or demolition order in respect of any building or structure?
 - (c) Has the vendor a Building Certificate which relates to all current buildings or structures? If so, it should be handed over on completion. Please provide a copy in advance.
 - (d) Has the vendor a Final Occupation Certificate issued under the *Environmental Planning and Assessment Act 1979* for all current buildings or structures? If so, it should be handed over on completion. Please provide a copy in advance.
 - (e) In respect of any residential building work carried out in the last 7 years:
 - (i) please identify the building work carried out;
 - (ii) when was the building work completed?
 - (iii) please state the builder's name and license number;
 - (iv) please provide details of insurance under the *Home Building Act 1989*.
 15. Has the vendor (or any predecessor) or the Owners Corporation entered into any agreement with or granted any indemnity to the Council or any other authority concerning any development on the property or the common property?
 16. If a swimming pool is on the common property:
 - (a) when did construction of the swimming pool commence?
 - (b) is the swimming pool surrounded by a barrier which complies with the requirements of the *Swimming Pools Act 1992*?
 - (c) if the swimming pool has been approved under the *Local Government Act 1993*, please provide details.
 - (d) are there any outstanding notices or orders?
 17.
 - (a) If there are any party walls, please specify what rights exist in relation to each party wall and produce any agreement. The benefit of any such agreement should be assigned to the purchaser on completion.
 - (b) Is the vendor aware of any dispute regarding boundary or dividing fences or party walls?
 - (c) Has the vendor received any notice, claim or proceedings under the *Dividing Fences Act 1991* or the *Encroachment of Buildings Act 1922*?

Affectations, notices and claims

18. In respect of the property and the common property:
 - (a) Is the vendor aware of any rights, licenses, easements, covenants or restrictions as to use of them other than those disclosed in the Contract?
 - (b) Has any claim been made by any person to close, obstruct or limit access to or from them or to prevent the enjoyment of any easement appurtenant to them?
 - (c) Is the vendor aware of:
 - (i) any road, drain, sewer or storm water channel which intersects or runs through them?
 - (ii) any dedication to or use by the public of any right of way or other easement over any part of them?
 - (iii) any latent defects in them?
 - (d) Has the vendor any notice or knowledge of them being affected by the

following:

- (i) any resumption or acquisition or proposed resumption or acquisition?
- (ii) any notice requiring work to be done or money to be spent on them or any footpath or road adjoining? If so, such notice must be complied with prior to completion.
- (iii) any work done or intended to be done on them or the adjacent street which may create a charge on them or the cost of which might be or become recoverable from the purchaser?
- (iv) any sum due to any local or public authority recoverable from the purchaser? If so, it must be paid prior to completion.
- (v) any realignment or proposed realignment of any road adjoining them?
- (vi) any contamination of them?

Owners corporation management

- 19. Has the initial period expired?
- 20. If the property includes a utility lot, please specify the restrictions.
- 21. If there are any applications or orders under Chapter 5 of the Act, please provide details.
- 22. Do any special expenses (as defined in clause 23.2 of the Contract) exceed 1% of the price?
Capacity
- 23. If the Contract discloses that the vendor is a trustee, evidence should be produced to establish the trustee's power of sale.
Requisitions and transfer
- 24. If the transfer or any other document to be handed over on completion is executed pursuant to a power of attorney, then at least 7 days prior to completion a copy of the registered power of attorney should be produced and found in order.
- 25. If the vendor has or is entitled to have possession of the title deeds the Certificate Authentication Code must be provided 7 days prior to settlement.
- 26. Searches, surveys, enquiries and inspection of title deeds must prove satisfactory.
- 27. The purchaser reserves the right to make further requisitions prior to completion.
- 28. Unless we are advised by you to the contrary prior to completion, it will be assumed that your replies to these requisitions remain unchanged as at completion date.

Schedule 3 Model by-laws for residential strata schemes

(Clause 37)

Note.

These by-laws do not apply to a strata scheme unless they are adopted by the owners corporation for the strata scheme or lodged with the strata plan.

1 Vehicles

An owner or occupier of a lot must not park or stand any motor or other vehicle on common property, or permit a motor vehicle to be parked or stood on common property, except with the prior written approval of the owners corporation or as permitted by a sign authorised by the owners corporation.

2 Changes to common property

- (1) An owner or person authorised by an owner may install, without the consent of the owners corporation:
 - (a) any locking or other safety device for protection of the owner's lot against intruders or to improve safety within the owner's lot, or
 - (b) any screen or other device to prevent entry of animals or insects on the lot, or
 - (c) any structure or device to prevent harm to children.
- (2) Any such locking or safety device, screen, other device or structure must be installed in a competent and proper manner and must have an appearance, after it has been installed, in keeping with the appearance of the rest of the building.
- (3) Clause (1) does not apply to the installation of any thing that is likely to affect the operation of fire safety devices in the lot or to reduce the level of safety in the lots or common property.
- (4) The owner of a lot must:
 - (a) maintain and keep in a state of good and serviceable repair any installation or structure referred to in clause (1) that forms part of the common property and that services the lot, and
 - (b) repair any damage caused to any part of the common property by the installation or removal of any locking or safety device, screen, other device or structure referred to in clause (1) that forms part of the common property and that services the lot.

3 Damage to lawns and plants on common property

An owner or occupier of a lot must not, except with the prior written approval of the owners corporation:

- (a) damage any lawn, garden, tree, shrub, plant or flower being part of or situated on common property, or
- (b) use for his or her own purposes as a garden any portion of the common property.

4 Obstruction of common property

An owner or occupier of a lot must not obstruct lawful use of common property by any person except on a temporary and non-recurring basis.

5 Keeping of animals

Note.

Select option A or B. If no option is selected, option A will apply.

Option A

- (1) An owner or occupier of a lot may keep an animal on the lot, if the owner or occupier gives the owners corporation written notice that it is being kept on the lot.
- (2) The notice must be given not later than 14 days after the animal commences to be kept on the lot.
- (3) If an owner or occupier of a lot keeps an animal on the lot, the owner or occupier must:
 - (a) keep the animal within the lot, and
 - (b) supervise the animal when it is on the common property, and
 - (c) take any action that is necessary to clean all areas of the lot or the common property that are soiled by the animal.

Option B

- (1) An owner or occupier of a lot may keep an animal on the lot or the common property with the written approval of the owners corporation.
- (2) The owners corporation must not unreasonably withhold its approval of the keeping of an animal on a lot or the common property and must give an owner or occupier written reasons for any refusal to grant approval.
- (3) If an owner or occupier of a lot keeps an animal on the lot, the owner or occupier must:
 - (a) keep the animal within the lot, and
 - (b) supervise the animal when it is on the common property, and
 - (c) take any action that is necessary to clean all areas of the lot or the common property that are soiled by the animal.
- (4) An owner or occupier of a lot who keeps an assistance animal on the lot must, if required to do so by the owners corporation, provide evidence to the owners corporation demonstrating that the animal is an assistance animal as referred to in section 9 of the *Disability Discrimination Act 1992* of the Commonwealth.

6 Noise

An owner or occupier of a lot, or any invitee of an owner or occupier of a lot, must not create any noise on a lot or the common property likely to interfere with the peaceful enjoyment of the owner or occupier of another lot or of any person lawfully using common property.

7 Behaviour of owners, occupiers and invitees

- (1) An owner or occupier of a lot, or any invitee of an owner or occupier of a lot, when on common property must be adequately clothed and must not use language or behave in a manner likely to cause offence or embarrassment to the owner or occupier of another lot or to any person lawfully using common property.
- (2) An owner or occupier of a lot must take all reasonable steps to ensure that invitees of the owner or occupier:
 - (a) do not behave in a manner likely to interfere with the peaceful enjoyment of the owner or occupier of another lot or any person lawfully using common property, and
 - (b) without limiting paragraph (a), that invitees comply with clause (1).

8 Children playing on common property

- (1) Any child for whom an owner or occupier of a lot is responsible may play on any area of the common property that is designated by the owners corporation for that purpose but may only use an area designated for swimming while under adult supervision.
- (2) An owner or occupier of a lot must not permit any child for whom the owner or occupier is responsible, unless accompanied by an adult exercising effective control, to be or remain on common property that is a laundry, car parking area or other area of possible danger or hazard to children.

9 Smoke penetration

Note.

Select option A or B. If no option is selected, option A will apply.

Option A

- (1) An owner or occupier, and any invitee of the owner or occupier, must not smoke tobacco or any other substance on the common property.
- (2) An owner or occupier of a lot must ensure that smoke caused by the smoking of tobacco or any other substance by the owner or occupier, or any invitee of the owner or occupier, on the lot does not penetrate to the common property or any other lot.

Option B

- (1) An owner or occupier of a lot, and any invitee of the owner or occupier, must not smoke tobacco or any other substance on the common property, except:
 - (a) in an area designated as a smoking area by the owners corporation, or
 - (b) with the written approval of the owners corporation.
- (2) A person who is permitted under this by-law to smoke tobacco or any other substance on common property must ensure that the smoke does not penetrate to any other lot.
- (3) An owner or occupier of a lot must ensure that smoke caused by the smoking of tobacco or any other substance by the owner or occupier, or any invitee of the owner or occupier, on the lot does not penetrate to the common property or any other lot.

10 Preservation of fire safety

The owner or occupier of a lot must not do any thing or permit any invitees of the owner or occupier to do any thing on the lot or common property that is likely to affect the operation of fire safety devices in the parcel or to reduce the level of fire safety in the lots or common property.

11 Storage of inflammable liquids and other substances and materials

- (1) An owner or occupier of a lot must not, except with the prior written approval of the owners corporation, use or store on the lot or on the common property any inflammable chemical, liquid or gas or other inflammable material.
- (2) This by-law does not apply to chemicals, liquids, gases or other material used or intended to be used for domestic purposes, or any chemical, liquid, gas or other material in a fuel tank of a motor vehicle or internal combustion engine.

12 Appearance of lot

- (1) The owner or occupier of a lot must not, without the prior written approval of the owners corporation, maintain within the lot anything visible from outside the lot that, viewed from outside the lot, is not in keeping with the rest of the building.

- (2) This by-law does not apply to the hanging of any clothing, towel, bedding or other article of a similar type in accordance with by-law 14.

13 Cleaning windows and doors

- (1) Except in the circumstances referred to in clause (2), an owner or occupier of a lot is responsible for cleaning all interior and exterior surfaces of glass in windows and doors on the boundary of the lot, including so much as is common property.
- (2) The owners corporation is responsible for cleaning regularly all exterior surfaces of glass in windows and doors that cannot be accessed by the owner or occupier of the lot safely or at all.

14 Hanging out of washing

- (1) An owner or occupier of a lot may hang any washing on any lines provided by the owners corporation for that purpose. The washing may only be hung for a reasonable period.
- (2) An owner or occupier of a lot may hang washing on any part of the lot other than over the balcony railings. The washing may only be hung for a reasonable period.
- (3) In this by-law:

washing includes any clothing, towel, bedding or other article of a similar type.

15 Disposal of waste—bins for individual lots [applicable where individual lots have bins]

- (1) An owner or occupier of a lot must not deposit or throw on the common property any rubbish, dirt, dust or other material or discarded item except with the prior written approval of the owners corporation.
- (2) An owner or occupier of a lot must not deposit in a toilet, or otherwise introduce or attempt to introduce into the plumbing system, any item that is not appropriate for any such disposal (for example, a disposable nappy).
- (3) An owner or occupier must:
- (a) comply with all reasonable directions given by the owners corporation as to the disposal and storage of waste (including the cleaning up of spilled waste) on common property, and
 - (b) comply with the local council's guidelines for the storage, handling, collection and disposal of waste.
- (4) An owner or occupier of a lot must maintain bins for waste within the lot, or on any part of the common property that is authorised by the owners corporation, in clean and dry condition and appropriately covered.
- (5) An owner or occupier of a lot must not place any thing in the bins of the owner or occupier of any other lot except with the permission of that owner or occupier.
- (6) An owner or occupier of a lot must place the bins within an area designated for collection by the owners corporation not more than 12 hours before the time at which waste is normally collected and, when the waste has been collected, must promptly return the bins to the lot or other area authorised for the bins.
- (7) An owner or occupier of a lot must notify the local council of any loss of, or damage to, bins provided by the local council for waste.
- (8) The owners corporation may give directions for the purposes of this by-law by posting signs on the common property with instructions on the handling of waste that are consistent with the local council's requirements or giving notices in writing to owners or occupiers of lots.

(9) In this by-law:

bin includes any receptacle for waste.

waste includes garbage and recyclable material.

16 Disposal of waste—shared bins [applicable where bins are shared by lots]

- (1) An owner or occupier of a lot must not deposit or throw on the common property any rubbish, dirt, dust or other material or discarded item except with the prior written approval of the owners corporation.
- (2) An owner or occupier of a lot must not deposit in a toilet, or otherwise introduce or attempt to introduce into the plumbing system, any item that is not appropriate for any such disposal (for example, a disposable nappy).
- (3) An owner or occupier must:
 - (a) comply with all reasonable directions given by the owners corporation as to the disposal and storage of waste (including the cleaning up of spilled waste) on common property, and
 - (b) comply with the local council's guidelines for the storage, handling, collection and disposal of waste.
- (4) The owners corporation may give directions for the purposes of this by-law by posting signs on the common property with instructions on the handling of waste that are consistent with the local council's requirements or giving notices in writing to owners or occupiers of lots.

(5) In this by-law:

bin includes any receptacle for waste.

waste includes garbage and recyclable material.

17 Change in use or occupation of lot to be notified

- (1) An occupier of a lot must notify the owners corporation if the occupier changes the existing use of the lot.
- (2) Without limiting clause (1), the following changes of use must be notified:
 - (a) a change that may affect the insurance premiums for the strata scheme (for example, if the change of use results in a hazardous activity being carried out on the lot, or results in the lot being used for commercial or industrial purposes rather than residential purposes),
 - (b) a change to the use of a lot for short-term or holiday letting.
- (3) The notice must be given in writing at least 21 days before the change occurs or a lease or sublease commences.

18 Compliance with planning and other requirements

- (1) The owner or occupier of a lot must ensure that the lot is not used for any purpose that is prohibited by law.
- (2) The owner or occupier of a lot must ensure that the lot is not occupied by more persons than are allowed by law to occupy the lot.



NEW SOUTH WALES LAND REGISTRY SERVICES - TITLE SEARCH

FOLIO: 3/SP69646

SEARCH DATE	TIME	EDITION NO	DATE
11/5/2022	11:14 AM	4	27/6/2018

LAND

LOT 3 IN STRATA PLAN 69646
AT OURIMBAH
LOCAL GOVERNMENT AREA CENTRAL COAST

FIRST SCHEDULE

ANDREW STUART BLYTHIN (T 9692685)

SECOND SCHEDULE (2 NOTIFICATIONS)

- 1 INTERESTS RECORDED ON REGISTER FOLIO CP/SP69646
- 2 AN454367 MORTGAGE TO COMMONWEALTH BANK OF AUSTRALIA

NOTATIONS

UNREGISTERED DEALINGS: NIL

*** END OF SEARCH ***

* Any entries preceded by an asterisk do not appear on the current edition of the Certificate of Title. Warning: the information appearing under notations has not been formally recorded in the Register. InfoTrack an approved NSW Information Broker hereby certifies that the information contained in this document has been provided electronically by the Registrar General in accordance with Section 96B(2) of the Real Property Act 1900.

Copyright © Office of the Registrar-General 2022
Received: 11/05/2022 11:14:17



NEW SOUTH WALES LAND REGISTRY SERVICES - TITLE SEARCH

FOLIO: CP/SP69646

SEARCH DATE	TIME	EDITION NO	DATE
11/5/2022	11:15 AM	3	19/3/2021

LAND

THE COMMON PROPERTY IN THE STRATA SCHEME BASED ON STRATA PLAN 69646
WITHIN THE PARCEL SHOWN IN THE TITLE DIAGRAM

AT OURIMBAH
LOCAL GOVERNMENT AREA CENTRAL COAST
PARISH OF GOSFORD COUNTY OF NORTHUMBERLAND
TITLE DIAGRAM SP69646

FIRST SCHEDULE

THE OWNERS - STRATA PLAN NO. 69646
ADDRESS FOR SERVICE OF DOCUMENTS:
C/- ALL STRATA SERVICES
LOCKED BAG 2908
CENTRAL COAST BUSINESS CENTRE
LISAROW NSW 2252

SECOND SCHEDULE (4 NOTIFICATIONS)

- 1 RESERVATIONS AND CONDITIONS IN THE CROWN GRANT(S)
- 2 ATTENTION IS DIRECTED TO THE RESIDENTIAL SCHEMES MODEL BY-LAWS
CONTAINED IN THE STRATA SCHEMES MANAGEMENT REGULATION APPLICABLE
AT THE DATE OF REGISTRATION OF THE SCHEME
KEEPING OF ANIMALS - OPTION A HAS BEEN ADOPTED
- 3 F656244 COVENANT AFFECTING THE PART(S) SHOWN SO BURDENED IN
THE TITLE DIAGRAM
- 4 AH949956 CHANGE OF BY-LAWS

SCHEDULE OF UNIT ENTITLEMENT (AGGREGATE: 1000)

STRATA PLAN 69646

LOT	ENT	LOT	ENT	LOT	ENT	LOT	ENT
1	- 90	2	- 100	3	- 77	4	- 100
5	- 104	6	- 94	7	- 90	8	- 93
9	- 130	10	- 122				

NOTATIONS

UNREGISTERED DEALINGS: NIL

*** END OF SEARCH ***

* Any entries preceded by an asterisk do not appear on the current edition of the Certificate of Title. Warning: the information appearing under notations has not been formally recorded in the Register. InfoTrack an approved NSW Information Broker hereby certifies that the information contained in this document has been provided electronically by the Registrar General in accordance with Section 96B(2) of the Real Property Act 1900.

Copyright © Office of the Registrar-General 2022
Received: 11/05/2022 11:15:20

STRATA PLAN FORM 1

WARNING: CREASING OR FOLDING WILL LEAD TO REJECTION

OFFICE USE ONLY

STRATA CERTIFICATE

Name of Council/ Accredited Certifier: **WYONG SHIRE**, being satisfied that the requirements of the Strata Schemes (Freehold Development) Act 1973 or Strata Schemes (Leasehold Development) Act 1986 have been complied with, approves the proposal:
 Strata plan/ leasehold subdivision
 illustrated in the annexure to this certificate.

The accredited certifier is satisfied that the plan is consistent with a right development consent in force, and that all conditions of the development consent that by its terms are required to be complied with before a strata certificate may be issued, have been complied with.
 The strata plan/strata plan of subdivision is part of a development scheme. The Council/ accredited certifier is satisfied that the plan is consistent with any applicable conditions of any development consent and that the plan gives effect to the stages of the strata development contract to which it relates.
 The Council does not object to the encroachment of the building beyond the alignment of:

The accredited certifier is satisfied that the building complies with a relevant development consent in force that allows the encroachment.
 This approval is given on the condition that the use of lot (S)

(being utility kiosk designed to be used primarily for the storage of accommodation of boats, motor vehicles or goods and not for human occupation as a residence, office, shop or the like) is restricted to the proprietor or occupier of a lot or proposed lot (not being such a utility kiosk) the subject of the strata scheme concerned, as referred to in section 39 of the Strata Schemes (Freehold Development) Act 1973 or section 66 of the Strata Schemes (Leasehold Development) Act 1986.

Date: **13-3-03** *Condition or condition applicable
 Subdivision No.: **7608** Accreditation No.:
 Relevant Development Consent No.: **3516/02**
 Issued by: **WYONG SHIRE COUNCIL**
 Authorised Person/General Manager/Accredited Certifier:

SURVEYORS CERTIFICATE

PETER EDWARD STONIE
10 HAMIE BOULEVARD
KILLARNEY VALE, NSW, 2261
 a surveyor registered under the Surveyors Act 1929, hereby certify that:

- (1) each applicable requirement of
 - * Schedule 1A to the Strata Schemes (Freehold Development) Act 1973
 - * Schedule 1A to the Strata Schemes (Leasehold Development) Act 1986 has been met.
- (2) * (a) the building encroaches on a public place
 * (b) the building encroaches on land (other than a public place), in respect of which an appropriate easement:
 - * has been created by registered plan
 - * is to be created under section 88B of the Conveyancing Act 1919
- (3) * the survey information recorded in the accompanying location plan is correct

Date: **10th DECEMBER 2002**
 Signature: *[Signature]*
 * Date if applicable + State whether dealing or plan, and quote registered number.

RESIDENTIAL

(Insert type being adopted) Model By-Laws adopted for this scheme
 Keeping of Animals: Option A/B/C
 Schedule of By-Laws in _____ sheets filed with plan
 The By-Laws apply: _____
 State out whether inapplicable

SCHEDULE OF UNIT ENTITLEMENT

LOT	UNIT ENTITLEMENT
1	90
2	100
3	77
4	100
5	104
6	94
7	90
8	93
9	130
10	122
AGGREGATE	1000

PLAN OF SUBDIVISION OF LOT 427 IN DP1047501

L.G.A: WYONG SHIRE Suburb/Locality: **DURIMBAH**

Parish: GOSFORD County: **NORTHLUMBERLAND**

SHEET 1 OF 6 SHEETS

Name of, and address for THE OWNERS' CORPORATION, STRATA PLAN N° 69646
 service of notices on, the N°7
 owners corporation. KING STREET, DURIMBAH, NSW 2258
 (Address required on original strata plan only)

FOR LOCATION PLAN SEE SHEET 2

Signatures, seals and statements of intention to create easements, restrictions on the use of land or positive covenants

BROADWAY CREDIT UNION LIMITED, MORTGAGEE UNDER MORTGAGE NOS. 8305187 AND 8305119 HEREBY CONSENTS TO THE REGISTRATION OF THE WITHIN PLAN
THE SEAL OF BROADWAY CREDIT UNION LTD.
 was hereunto affixed by authority of the Board and in accordance with the rules of the Credit Union in the presence of:

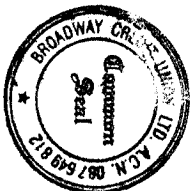
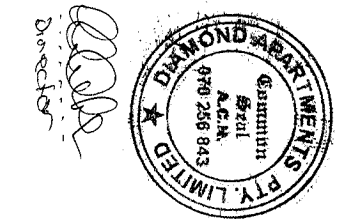

[Signature] Wendy Bolly Furkerson
 Director
[Signature] *[Signature]*
 Authorised Officer
 6 0 3 3 7 2 0 7 8 1 1 5
 Authorised Officer

STRATA PLAN FORM 2

WARNING: CREASING OR FOLDING WILL LEAD TO REJECTION

Sheet No. 3 of 6 Sheets

SP69646

GROUND FLOOR

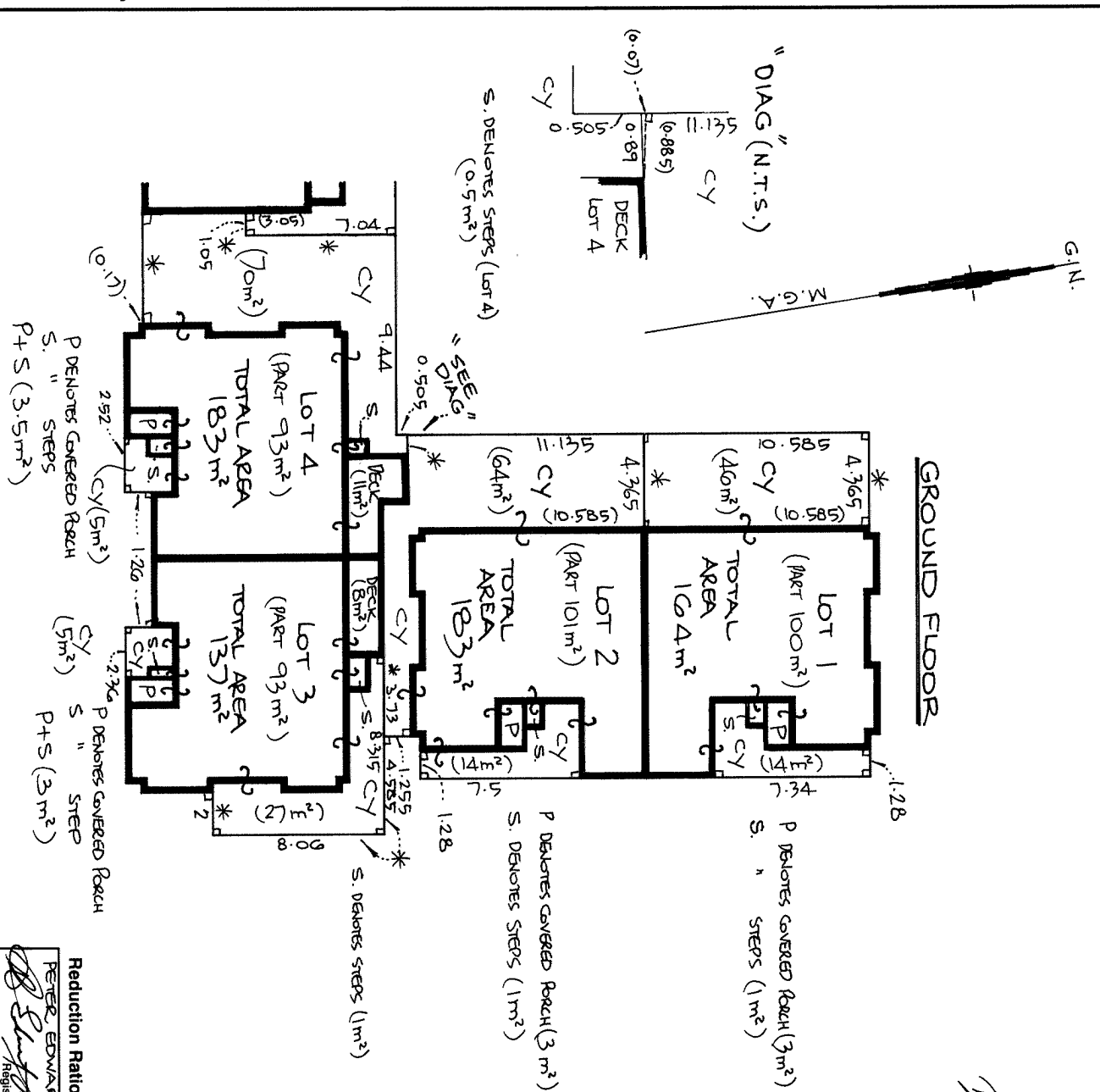

Note:

- * DENOTES COLOURBOND FENCE/KOPERS LOG REMAINS WALL FENCE WHICH FORM THE COURTYARD GARDEN SPACE BOUNDARIES & WHICH ARE COMMON PROPERTY
- CY DENOTES COURTYARD GARDEN SPACE
- P DENOTES COVERED PARCH
- D DENOTES TIMBER DECK
- S DENOTES STEP OR STEPS
- H DENOTES 90° (RIGHT ANGULAR) CONNECTION
- PARCHES ARE COVERED
- THE COURTYARD GARDEN SPACES ARE LIMITED IN HEIGHT TO 3m BELOW & 8m ABOVE THE UPPER SURFACE OF THEIR RESPECTIVE ADJACENT LOT'S GROUND FLOOR, EXCEPT WHERE COVERED
- DECKS ARE LIMITED IN HEIGHT FROM THEIR RESPECTIVE UPPER SURFACE TO THE UNDERSIDE OF THEIR RESPECTIVE OVERHANGING GUTTERINGS (OR OVERHANGING FIRST FLOOR DECK FOR LOT 5)
- LANDINGS & STEPS HAVE THE SAME HEIGHT LIMITATIONS AS THE DECKS
- SOME PART AREAS ARE SHOWN TO THE NEAREST HALF SQUARE METRE. MOST PART AREAS & ALL TOTAL AREAS ARE SHOWN TO THE NEAREST SQUARE METRE
- * THE STRUCTURE OF THE KOPERS LOG REMAINING WALLS AND COLOURBOND FENCES, WHICH FORM PARTS OF THE COURTYARD BOUNDARIES, ARE COMMON PROPERTY

Reduction Ratio 1: 200

Lengths are in metres

PETER EDWARD STONE
 Registered Surveyor 10/12/02
 SURVEYOR'S REFERENCE: 2021 SP (CHECK LIST)

Authorised Person/General Manager/Accredited Certifier

STRATA PLAN FORM 2

WARNING: CREATING OR FOLDING WILL LEAD TO REJECTION

Sheet No. 4 of 6 Sheets

SP69646

NOTE:
 * DENOTES COURSEBOUND FENCE /KOPERS LOG REMAINING WALL FENCE, WHICH FORM THE COURTYARD GARDEN SPACE BOUNDARIES & WHICH ARE COMMON PROPERTY
 CY DENOTES COURTYARD GARDEN SPACE
 P DENOTES COVERED PORCH
 S DENOTES STEP OR STERS
 L DENOTES 90° (RIGHT ANGULAR) CONNECTION
 - PORCHES ARE COVERED
 - THE COURTYARD GARDEN SPACES ARE LIMITED IN HEIGHT TO 3m BELOW & 8m ABOVE THE UPPER SURFACE OF THEIR RESPECTIVE ADJACENT LOT'S GROUND FLOOR, EXCEPT WHERE COVERED

- DECKS ARE LIMITED IN HEIGHT FROM THEIR RESPECTIVE UPPER SURFACE TO THE UNDERSIDE OF THEIR RESPECTIVE OVERHANGING GUTTERING (OR OVERHANGING FIRST FLOOR DECK FOR LOT 5)
 - LANDINGS & STERS HAVE THE SAME HEIGHT LIMITATIONS AS THE DECKS
 - SOME PART AREAS ARE SHOWN TO THE NEAREST HALF SQ. METRE. MOST PART AREAS & ALL TOTAL AREAS ARE SHOWN TO THE NEAREST SQ. METRE
 * THE STRUCTURE OF THE KOPERS LOG REMAINING WALLS AND COURSEBOUND FENCES WHICH FORM PARTS OF THE COURTYARD BOUNDARIES, ARE COMMON PROPERTY

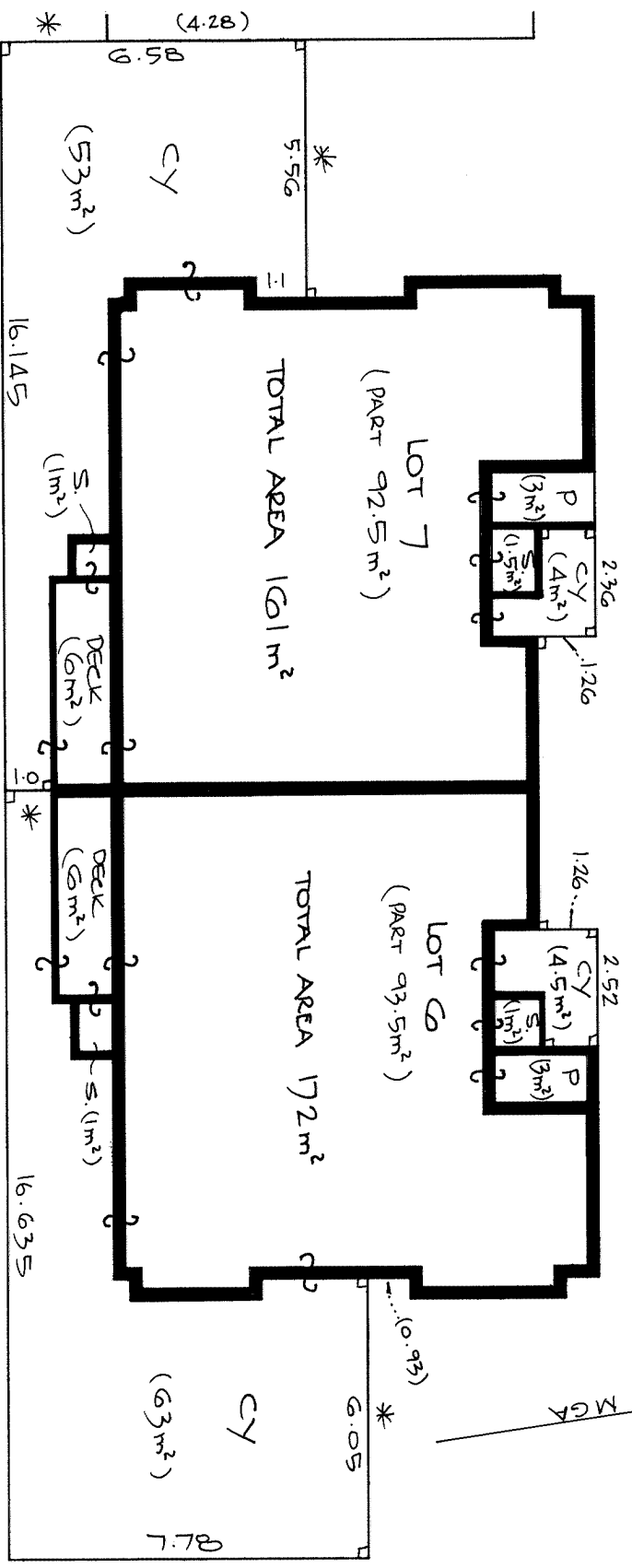

GROUND FLOOR

Reduction Ratio 1: 100
 Lengths are in metres

PETER EDWARD STONE
 Registered Surveyor 10/12/02
 Authorised Person/General Manager/Accredited Certifier
 SURVEYOR'S REFERENCE: 2027 SP (CHECK LIST)

STRATA PLAN FORM 2

WARNING: CREATING OR FOLDING WILL LEAD TO REJECTION

Sheet No. 5 of 6 Sheets

SP69646

DIAG 'C' (N.T.S.)

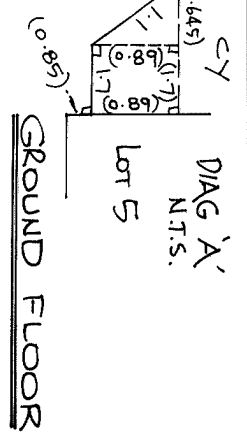

DIAG 'B' (N.T.S.)

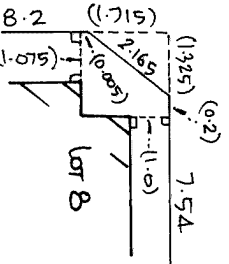

DIAG 'C' (N.T.S.)

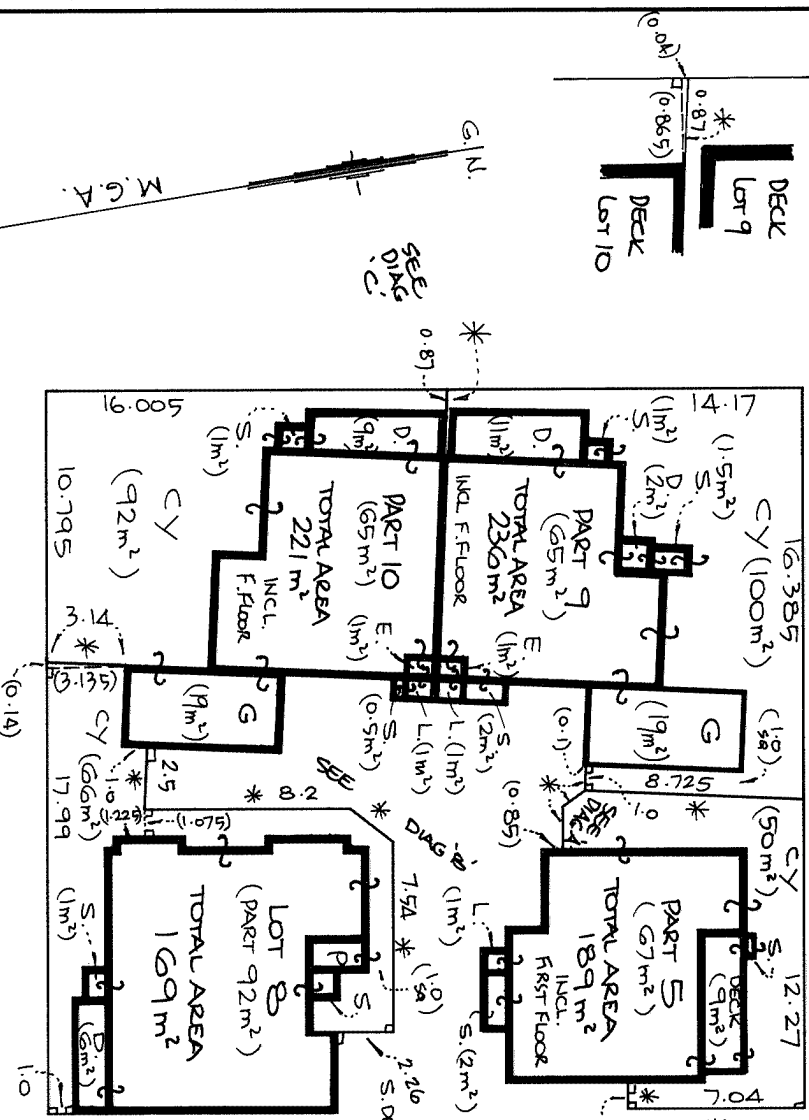

GROUND FLOOR

NOTE:
 * DENOTES ~~COURTYARD FENCE / KOPPELS LOG REMAINS~~
 WALL FENCE, WITHIN FORM THE COVERED GARAGE
 - SPACE BOUNDARIES & WITHIN ARE COMMON PROPERTY
 CY DENOTES COURTYARD GARAGE SPACE
 P DENOTES COVERED PORCH
 D. DENOTES TIMBER DECK
 S. " " STEP OR STEPS
 L DENOTES 90° (RIGHT ANGLUAR) CONNECTION
 - PORCHES ARE COVERED
 - THE COURTYARD GARAGE SPACES ARE LIMITED IN HEIGHT TO 3m BELOW & 8m ABOVE THE UPPER SURFACE OF THEIR RESPECTIVE ADJACENT LOT'S GROUND FLOOR, EXCEPT WHERE COVERED
 - DECKS ARE LIMITED IN HEIGHT FROM THEIR RESPECTIVE OVER SURFACE TO THE UNDERSIDE OF THEIR RESPECTIVE OVERHANGING GUTTERLINGS (OR OVERHANGING FIRST FLOOR DECK FOR LOT 5)
 L DENOTES LANDING

P DENOTES PORCH (LOT 8)
 (3m²)
 S. DENOTES STEPS (LOT 8)
 (1m²)

- LANDINGS & STEPS HAVE THE SAME HEIGHT LIMITATIONS AS THE DECKS
- SOME PART AREAS ARE SHOWN TO THE NEAREST HALF 50 M. MOST PART AREAS & ALL TOTAL AREAS ARE SHOWN TO THE NEAREST 50. METRE
- G. DENOTES GARAGE

* THE STRUCTURE OF THE KOPPELS LOG REMAINS WALLS AND COLOURBOND FENCES, WHICH FORM PARTS OF THE GARDEN BOUNDARIES, ARE COMMON PROPERTY

Reduction Ratio 1: 200

Lengths are in metres

PETER EDWARD STONE
 Registered Surveyor
 10/12/02

Authorised Person/Captial Manager/Accredited Certifier

SURVEYOR'S REFERENCE: 2027 SP (CHECKLIST)

WARNING: CREASING OR FOLDING WILL LEAD TO REJECTION

Sheet No. 6 of 6 Sheets

SP69646

*

G.N.



FIRST FLOOR

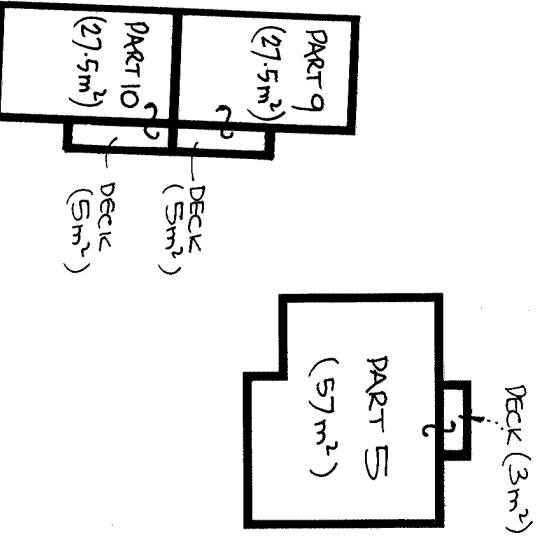

Reduction Ratio 1: 200

Lengths are in metres

PETER EDWARD STONE
Peter Edward Stone
Registered Surveyor
10112102

Authorised Person/General Manager/Accredited Certifier
[Signature]



SURVEYOR'S REFERENCE: 2027 SP (CHECKLIST)



Link Legal & Conveyancing
374 Main Rd
NORAVILLE NSW 2263

SECTION 10.7(2) PLANNING CERTIFICATE

Under Section 10.7 of the Environmental Planning and Assessment Act, 1979

Fee Paid:	\$62.00
Receipt No:	
Receipt Date:	18 October 2022
Property Address:	3/7 King Street, OURIMBAH NSW 2258
Property Description:	Lot 3 SP 69646
Property Owner:	Mr A S Blythin
Certificate No:	54222
Reference No:	JB:223384:224098
Date of Issue:	19-Oct-2022

The information contained within this certificate relates to the land.



Wyong Office: 2 Hely St / PO Box 20 Wyong NSW 2259

P 02 4306 7900 | **E** ask@centralcoast.nsw.gov.au | **W** centralcoast.nsw.gov.au | ABN 73 149 644 003

**ADVICE PROVIDED PURSUANT TO S.10.7(2) OF THE ENVIRONMENTAL
PLANNING AND ASSESSMENT ACT 1979**

1	NAMES OF RELEVANT PLANNING INSTRUMENTS AND DEVELOPMENT CONTROL PLANS
----------	---

(1) Environmental Planning Instruments and Development Control Plans which apply to the land

Central Coast Local Environmental Plan 2022

Central Coast Development Control Plan 2022

Environment Planning Policy (Exempt and Complying Development Codes) 2008
State Environment Planning Policy (Building Sustainability Index: BASIX) 2004
State Environment Planning Policy No. 65 – Design Quality of Residential Apartment Development
State Environment Planning Policy (Primary Production) 2021
State Environment Planning Policy (Transport and Infrastructure) 2021
State Environment Planning Policy (Biodiversity and Conservation) 2021
State Environment Planning Policy (Resilience and Hazards) 2021
State Environment Planning Policy (Industry and State Employment) 2021
State Environment Planning Policy (Resources and Energy) 2021
State Environment Planning Policy (Planning Systems) 2021
State Environmental Planning Policy (Housing) 2021

(2) Proposed Environmental Planning Instruments and Draft Development Control Plans which will apply to the land and is or has been the subject of community consultation or public exhibition

Proposed State Environmental Planning Policy (Exempt & Complying Development Codes) 2008
Proposed State Environmental Planning Policy (Regional Infrastructure Contributions)
Proposed State Environmental Planning Policy (Transport and Infrastructure) 2021
Proposed State Environmental Planning Policy (Primary Production) 2021
Proposed State Environmental Planning Policy (Building Sustainability Index: BASIX) 2004
Standard Instrument (Local Environmental Plans) Order 2006

2	ZONING AND LAND USE UNDER RELEVANT PLANNING INSTRUMENTS
----------	--

(a) Identity of the Zone

Lot 3 SP 69646
R1 General Residential
Lot 3 SP 69646
R2 Low Density Residential

(b) For each of the environmental planning instruments referred to in clause 1, please refer to the attached land use table to determine (i), (ii) and (iii) listed below:

- (i) development that may be carried out within the zone without the need for development consent,
- (ii) development which may not be carried out within the zone except with development consent and
- (iii) development which is prohibited within the zone.

(c) Whether additional permitted uses apply to the land

Additional Permitted Uses **do not** apply to this land.

(d) Development Standards applying to the land that fix minimum land dimensions for the erection of a dwelling-house

There are no development standards applying to the land that fix minimum land dimensions for the erection of a dwelling-house on the land. However there are minimum lot sizes applying to the subdivision of land, and in some zones the entitlement to erect a dwelling-house, or carry out other types of residential development, is linked to that minimum lot size.

(e) Land includes or comprises critical habitat

No

(f) Land is in a conservation area

No

(g) Item of environmental heritage is situated on the land

None

3	CONTRIBUTION PLANS
----------	---------------------------

This land is subject to Shire wide Infrastructure, Services and Facilities Development Contributions Plan.

The land is subject to the Ourimbah District Development Contributions Plan.

This land is subject to the Central Coast Regional Section 7.12 Development Contributions Plan 2019

4	COMPLYING DEVELOPMENT
----------	------------------------------

Whether or not the land is land on which complying development can be carried out under each of the codes for complying development because of the provisions of clause 1.17A(1)(c) to (e), (2), (3) and (4), 1.18(1)(c3) and 1.19 of *State Environmental Planning Policy (Exempt and Complying Development Codes) 2008*?

GENERAL HOUSING CODE

Complying Development under the General Housing Code **may** be carried out on the land.

RURAL HOUSING CODE

Complying development under the Rural Housing Code **may** be carried out on the land providing the land is not less than the minimum lot size for the erection of a dwelling house under the Wyong Local Environmental Plan 2013.

LOW RISE HOUSING DIVERSITY CODE

Complying Development under the Low Rise Housing Diversity Code **may** be carried out on the land.

GREENFIELD HOUSING CODE

Greenfield Housing Code **is not** applicable to this land.

HOUSING ALTERATIONS CODE

Complying development under the Housing Alterations Code **may** be carried out on the land.

GENERAL DEVELOPMENT CODE

Complying development under the General Development Code **may** be carried out on the land.

COMMERCIAL AND INDUSTRIAL ALTERATIONS CODE

Complying development under the Commercial and Industrial Alterations Code **may** be carried out on the land.

COMMERCIAL AND INDUSTRIAL (NEW BUILDINGS AND ADDITIONS) CODE

Complying development under the Commercial and Industrial (New Buildings and Additions)

Code **may** be carried out on the land.

CONTAINER RECYCLING FACILITIES CODE

Complying Development under the Container Recycling Facilities Code **may** be carried out on the land.

SUBDIVISIONS CODE

Complying development under the Subdivisions Code **may** be carried out on the land.

DEMOLITION CODE

Complying development under the Demolition code **may** be carried out on the land.

FIRE SAFETY CODE

Complying development under the Fire Safety Code **may** be carried out on the land.

5	EXEMPT DEVELOPMENT
----------	---------------------------

Whether or not the land is land on which exempt development may be carried out under each of the exempt development codes under *State Environmental Planning Policy (Exempt and Complying Development Codes) 2008* because of that Policy, clause 1.16(1) (b1)–(d) or 1.16A.

GENERAL EXEMPT DEVELOPMENT CODE

Exempt development under the General Exempt Development Code applies to this land. This information needs to be read in conjunction with the whole of the State Environmental Planning Policy (Exempt and Complying Development Codes) 2008.

ADVERTISING AND SIGNAGE EXEMPT DEVELOPMENT CODE

Exempt development under the Advertising and Signage Exempt Development Code applies to this land. This information needs to be read in conjunction with the whole of the State Environmental Planning Policy (Exempt and Complying Development Codes) 2008.

TEMPORARY USES AND STRUCTURES EXEMPT DEVELOPMENT CODE

Exempt development under the Temporary Uses and Structures Exempt Development Code applies to this land. This information needs to be read in conjunction with the whole of the State Environmental Planning Policy (Exempt and Complying Development Codes) 2008.

6

AFFECTED BUILDING NOTICES AND BUILDING PRODUCT RECTIFICATION ORDERS (*BUILDING PRODUCT SAFETY ACT 2017*)

1(a) Is there any affected building notice of which the council is aware that is in force in respect of the land?

No

1(b) Is there any building product rectification order of which the council is aware that is in force in respect of the land and has not been fully complied with?

No

1(c) Is there any notice of intention to make a building product rectification order of which the council is aware has been given in respect of the land and is outstanding?

No

In this section—

affected building notice has the same meaning as in the *Building Products (Safety) Act 2017*, Part 4.

building product rectification order has the same meaning as in the *Building Products (Safety) Act 2017*

7

LAND RESERVED FOR ACQUISITION

The following environmental planning instruments and proposed environmental planning instruments make provisions for the acquisition of the land by a public authority as referred to in Section 3.15 of the Act:

Nil

8

ROAD WIDENING AND ROAD ALIGNMENT

(a) DIVISION 2 OF PART 3 OF THE *ROADS ACT 1993*

The land is not affected by road realignment or road widening under the above.

(b) ENVIRONMENTAL PLANNING INSTRUMENT

The land is not affected by road widening or road re-alignment under the above.

(c) COUNCIL RESOLUTIONS

The land is not affected by road widening or road re-alignment under the above.

9

FLOOD RELATED DEVELOPMENT CONTROLS

- (1) The land or part of the land **is not** within the flood planning area and **is not** subject to flood related development controls.
- (2) The land or part of the land **is not** between the flood planning area and the probable maximum flood and **is not** subject to flood related development controls.
- (3) In this section—

flood planning area has the same meaning as in the Floodplain Development Manual.

Floodplain Development Manual means the Floodplain Development Manual (ISBN 0 7347 5476 0) published by the NSW Government in April 2005.

probable maximum flood has the same meaning as in the Floodplain Development Manual.

10	COUNCIL AND OTHER PUBLIC AUTHORITY POLICIES ON HAZARD RISK RESTRICTIONS
-----------	--

This land is **not** affected by a policy that restricts the development of the land because of the likelihood of land slip, bushfire, tidal inundation, subsidence, acid sulphate soils or any other risk (other than flooding).

In this section—

adopted policy means a policy adopted—

- (a) by the council, or
- (b) by another public authority, if the public authority has notified the council that the policy will be included in a planning certificate issued by the council.

11	BUSH FIRE PRONE LAND
-----------	-----------------------------

The information currently available to Council indicates that **all** of the land is bush fire prone land (as defined in the Act).

12	LOOSE-FILL ASBESTOS INSULATION
-----------	---------------------------------------

This land does not include any residential premises (within the meaning of Division 1A of Part 8 of the *Home Building Act 1989*) that are listed on the register that is required to be maintained under that Division. That register lists residential premises that contain or have contained loose-fill asbestos insulation.

13	MINE SUBSIDENCE
-----------	------------------------

The land **IS NOT WITHIN** a Mine Subsidence District declared under section 20 of the *Coal Mine Subsidence Compensation Act 2017*.

14	PAPER SUBDIVISION INFORMATION
-----------	--------------------------------------

- (1) The name of any development plan adopted by a relevant authority that:
- (a) applies to this land or
 - (b) that is proposed to be subject to a consent ballot.

Nil

- (2) The date of any subdivision order that applies to this land.

Not applicable

Words and expressions used in this clause have the same meaning as they have in Part 10 of the *Environmental Planning and Assessment Regulation 2021* and Schedule 7 of the *Environmental Planning and Assessment Act 1979*.

15	PROPERTY VEGETATION PLANS
-----------	----------------------------------

Council **has not** been notified by Local Land Services – Greater Sydney that the land is subject to a property vegetation plan approved under Part 4 of the Native Vegetation Act 2003.

16	BIODIVERSITY STEWARDSHIP SITES
-----------	---------------------------------------

Council **has not** been notified by the Director-General of the Department of Planning and Environment that the land is a biodiversity stewardship site under a biodiversity stewardship agreement under Part 5 of the Biodiversity Conservation Act, 2016.

Note: Biodiversity stewardship agreements include biobanking agreements under the *Threatened Species Conservation Act 1995*, Part 7A that are taken to be biodiversity stewardship agreements under the *Biodiversity Conservation Act 2016*, Part 5.

17	BIODIVERSITY CERTIFIED LAND
-----------	------------------------------------

The land **is not** biodiversity certified land within the meaning of Part 8 of the *Biodiversity Conservation Act, 2016*.

Note: Biodiversity certified land includes land certified under the *Threatened Species Conservation Act 1995*, Part 7AA that is taken to be certified under the *Biodiversity Conservation Act 2016*, Part 8.

18	ORDERS UNDER TREES (DISPUTES BETWEEN NEIGHBOURS) ACT 2006
-----------	--

Council has not been notified of an Order issued under the Trees (Disputes between

Neighbours) Act 2006.

NOTE: This advice is based on information provided by the Land and Environment Court.

19	ANNUAL CHARGES UNDER <i>LOCAL GOVERNMENT ACT 1993</i> FOR COASTAL PROTECTION SERVICES THAT RELATE TO EXISTING COASTAL PROTECTION WORKS
-----------	---

The owner (or any previous owner) of the land has not consented in writing to the land being subject to annual charges under section 496B of the *Local Government Act 1993* for coastal protection services that relate to existing coastal protection works.

In this section—

existing coastal protection works has the same meaning as in the *Local Government Act 1993*, section 553B.

Note—

Existing coastal protection works are works to reduce the impact of coastal hazards on land, such as seawalls, revetments, groynes and beach nourishment, that existed before 1 January 2011.

20	WESTERN SYDNEY AEROTROPOLIS
-----------	------------------------------------

Not applicable to Central Coast Local Government Area

21	DEVELOPMENT CONSENT CONDITIONS FOR SENIORS HOUSING
-----------	---

Council is not aware of there being a valid Site Compatibility Certificate issued by the Director-General of the Department of Planning and Environment in respect of the land.

NOTE: This advice is based on information provided by the NSW Department of Planning and Environment.

22	SITE COMPATIBILITY CERTIFICATES AND DEVELOPMENT CONSENT CONDITIONS FOR AFFORDABLE RENTAL HOUSING
-----------	---

Council is not aware of there being a valid Site Compatibility Certificate issued by the Director-General of the Department of Planning and Environment in respect of the land.

NOTE: This advice is based on information provided by the NSW Department of Planning and Environment.

NOTE

CONTAMINATED LAND MANAGEMENT ACT 1997

The following matters are prescribed by section 59 (2) of the *Contaminated Land Management Act 1997* as additional matters to be specified in a planning certificate:

- (a) The land to which the certificate relates is significantly contaminated land within the meaning of that Act - if the land (or part of the land) is significantly contaminated land at the date when the certificate is issued,

No

- (b) The land to which the certificate relates is subject to a management order within the meaning of that Act - if it is subject to such an order at the date when the certificate is issued,

No

- (c) The land to which the certificate relates is the subject of an approved voluntary management proposal within the meaning of that Act - if it is the subject of such an approved proposal at the date when the certificate is issued,

No

- (d) The land to which the certificate relates is subject to an ongoing maintenance order within the meaning of that Act - if it is subject to such an order at the date when the certificate is issued,

No

- (e) The land to which the certificate relates is the subject of a site audit statement within the meaning of that Act - if a copy of such a statement has been provided at any time to the local authority issuing the certificate.

No

For any enquiries regarding this Certificate, please contact Council's Customer Contact Centre on 1300 463 954.



Tim Ennis
Signed on Behalf of Central Coast Council

LAND USE TABLE

Zone R1 General Residential Central Coast Local Environmental Plan 2022

1 Objectives of zone

- To provide for the housing needs of the community.
- To provide for a variety of housing types and densities.
- To enable other land uses that provide facilities or services to meet the day to day needs of residents.
- To promote best practice in the design of multi dwelling housing and other similar types of development.
- To ensure that non-residential uses do not adversely affect residential amenity or place unreasonable demands on services.

2 Permitted without consent

Home occupations; Recreation areas

3 Permitted with consent

Attached dwellings; Bed and breakfast accommodation; Boarding houses; Boat launching ramps; Boat sheds; Car parks; Caravan parks; Centre-based child care facilities; Community facilities; Dual occupancies; Dwelling houses; Educational establishments; Emergency services facilities; Environmental facilities; Environmental protection works; Exhibition homes; Exhibition villages; Flood mitigation works; Group homes; Home-based child care; Home businesses; Home industries; Home occupations (sex services); Hostels; Hotel or motel accommodation; Information and education facilities; Jetties; Multi dwelling housing; Neighbourhood shops; Oyster aquaculture; Places of public worship; Pond-based aquaculture; Residential flat buildings; Respite day care centres; Roads; Secondary dwellings; Semi-detached dwellings; Seniors housing; Serviced apartments; Sewage reticulation systems; Shop top housing; Signage; Tank-based aquaculture; Water recycling facilities; Water reticulation systems; Water storage facilities

4 Prohibited

Any development not specified in item 2 or 3

LAND USE TABLE

Zone R2 Low Density Residential Central Coast Local Environmental Plan 2022

1 Objectives of zone

- To provide for the housing needs of the community within a low density residential environment.
- To enable other land uses that provide facilities or services to meet the day to day needs of residents.
- To encourage best practice in the design of low density residential development.
- To ensure that non-residential uses do not adversely affect residential amenity or place unreasonable demands on services.
- To maintain and enhance the residential amenity and character of the surrounding area.

2 Permitted without consent

Home occupations; Recreation areas

3 Permitted with consent

Bed and breakfast accommodation; Boat launching ramps; Boat sheds; Building identification signs; Business identification signs; Centre-based child care facilities; Community facilities; Dual occupancies; Dwelling houses; Educational establishments; Emergency services facilities; Environmental facilities; Environmental protection works; Exhibition homes; Exhibition villages; Flood mitigation works; Group homes; Health consulting rooms; Home-based child care; Home businesses; Home industries; Information and education facilities; Jetties; Neighbourhood shops; Oyster aquaculture; Places of public worship; Pond-based aquaculture; Respite day care centres; Roads; Secondary dwellings; Semi-detached dwellings; Seniors housing; Sewage reticulation systems; Shop top housing; Tank-based aquaculture; Water recycling facilities; Water reticulation systems; Water storage facilities

4 Prohibited

Any development not specified in item 2 or 3



ABN 73 149 644 003
11 May 2022

Link Legal & Conveyancing
374 Main Rd
NORAVILLE NSW 2263

Dear Sir/Madam

Property: Lot 3 SP 69646
3/7 King Street, OURIMBAH NSW 2258
Your Reference: BLYTHIN RP:208169

Reference is made to your request for a Sewer Mains Diagram.

In this regard please now find attached a copy of the relevant information showing the sewer main/s location in relation to the property.

If you have any further enquiries regarding this diagram, please contact Central Coast Council's Customer Contact on 1300 463 954.

Yours faithfully

M Walsh

M Walsh
Signed on Behalf of Central Coast Council

Attach



Wyong Office: 2 Hely St / PO Box 20 Wyong NSW 2259 | **P** 1300 463 954 **DX 7306**

Gosford Office: 49 Mann St / PO Box 21 Gosford NSW 2250 | **P** 1300 463 954

E ask@centralcoast.nsw.gov.au | **W** www.centralcoast.nsw.gov.au | ABN 73 149 644 003

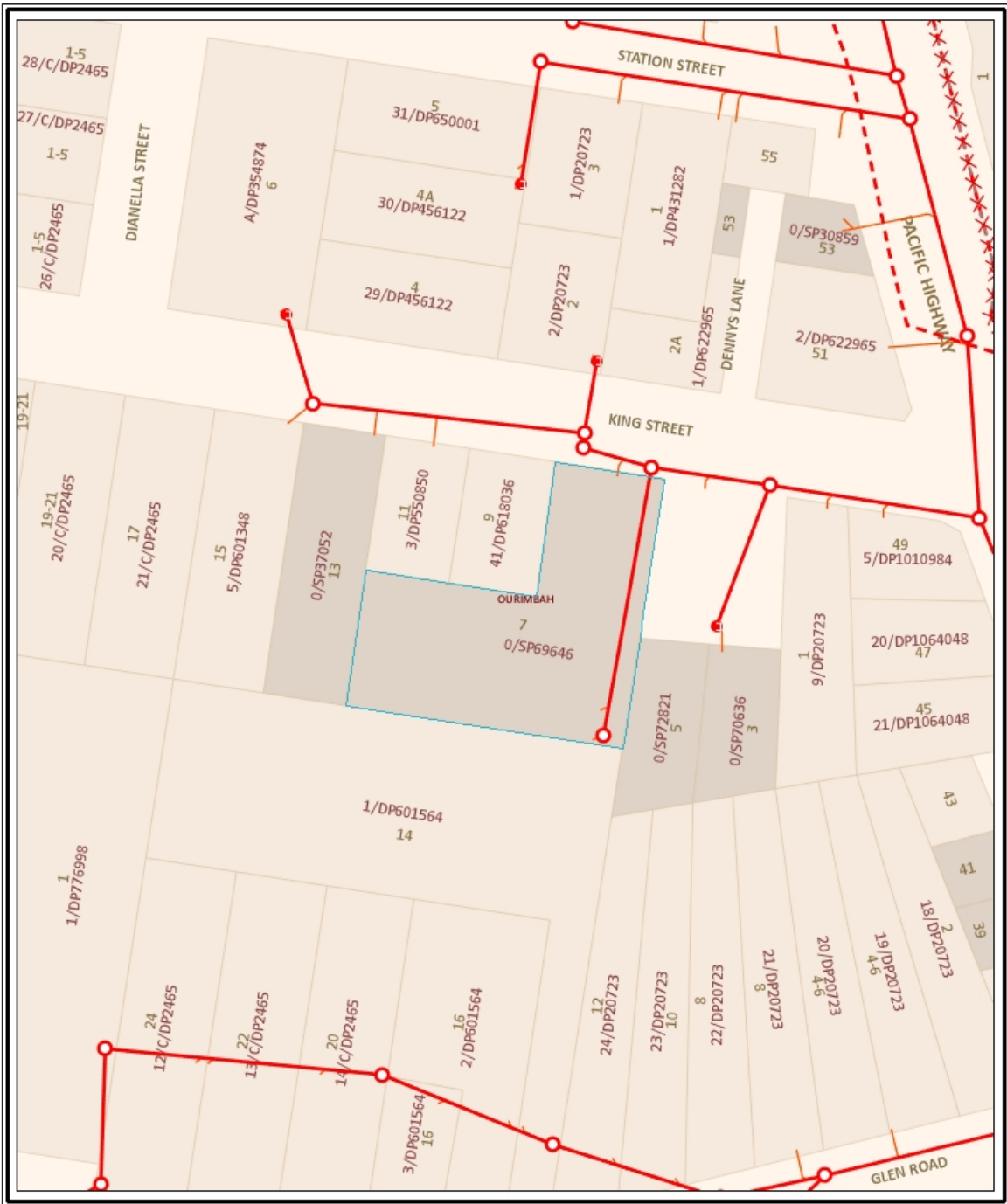

Warning Note for Underground Plant Locations

This plan may not have been adjusted to take into account changes to boundaries, levels, fences or structures subsequent to the installation of the services. This plan is not to scale and all measurements are approximate only. The services indicated are expected to be in proximity to the location and depth shown on the plan. Where it is intended to rely on the accurate location of the services, the exact position and depth of the services should be ascertained onsite by careful hand excavation. Council can provide an on-site advisory service on request to assist in this process. Please understand you will be held responsible for any damage caused to Council's services. Any indication of materials should be used as a guide only.

See Cadastre a part of the Digital Cadastre Database supplied by the Land and Property Information, (LPI), a division of the Department of Finance and Services. Any person whose legal rights may be affected, or intends to act on any cadastre information shown on this plan should verify such information by consulting the Department of Finance and Services before acting.



**Central Coast Council
Sewer Mains Diagram**

Not to Scale

Issue Date: 11/05/2022

Legend

- Access Chamber
- Dead End
- Manhole
- Sewer Manhole
- Vacuum Pot
- Valve
- Private Pump Station
- Pump Station
- Treatment Plant
- Reticulation Main
- Trunk Main
- Reticulation Main (Asbestos)
- Effluent Main
- Private Rising Main
- Rising Main
- Vacuum Main
- Rising Main (Asbestos)
- Sewer Encasement
- Abandoned Main
- Main Not In Use
- Applicant's Land



ABN 73 149 644 003

Your Ref: BLYTHIN RP:208169

11 May 2022

Link Legal & Conveyancing
374 Main Rd
NORAVILLE NSW 2263

Dear Sir/Madam

**3/7 King Street, OURIMBAH NSW 2258
Lot 3 SP 69646**

In reply to your request for an internal sewerage connection plan for the above lot, please find enclosed your copy of this plan.

Should you require any further information regarding this matter, please contact Central Coast Council's Customer Services Section on 1300 463 954.

Yours faithfully

M Walsh

M Walsh
Signed on Behalf of Central Coast Council

Attachment:



Wyong Office: 2 Hely St / PO Box 20 Wyong NSW 2259 | **P** 1300 463 954 **DX 7306**

Gosford Office: 49 Mann St / PO Box 21 Gosford NSW 2250 | **P** 1300 463 954

E ask@centralcoast.nsw.gov.au | **W** www.centralcoast.nsw.gov.au | ABN 73 149 644 003

3/7 King Street, OURIMBAH NSW 2258
Lot 3 SP 69646

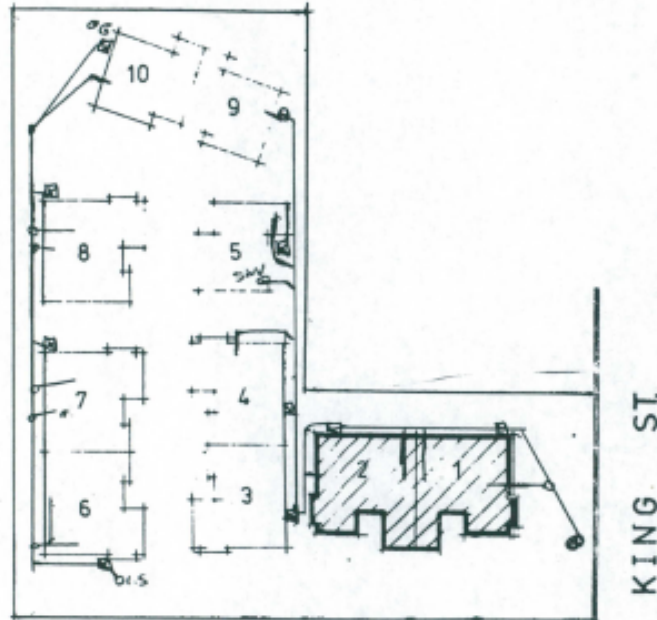

SITE PLAN

WYONG SHIRE COUNCIL
BUILDING APPROVED
Subject to conditions enumerated on
attached permit
BLB Requirements complied with
DATE 1. 11. 72
3432/85
D. L. PALMER
DIRECTOR HEALTH
BUILDING & DEVELOPMENTS
NOTE— This approval is NOT a
developmental approval

2 of 8

RESIDENTIAL TENANCY AGREEMENT
RESIDENTIAL TENANCIES REGULATION 2010

(SUITABLE FOR A TENANCY WHERE THE TERM OF RESIDENTIAL TENANCY AGREEMENT DOES NOT EXCEED 3 YEARS)

IMPORTANT NOTES ABOUT THIS AGREEMENT

1. The tenant should be given time to read this agreement (including the completed condition report which should be completed before or when giving this agreement to the tenant to sign) and to obtain appropriate advice if necessary.
2. A landlord or landlord's agent must give a tenant an approved form of information statement (which explains both parties' rights and obligations under this agreement) published by NSW Fair Trading before the tenant enters into the residential tenancy agreement.
3. If this agreement has a fixed term of more than 3 years, it must be annexed to the form approved by the Registrar-General for registration under the *Real Property Act 1900*. In that circumstance, the parties should seek their own independent legal advice to ensure this agreement is in a registrable form.

This agreement is made on 07 / 11 / 2019 at OURIMBAH 2258 ABN 65003484277 between

LANDLORD [Insert name of landlord(s) and contact details]

Name/s Andrew BLYTHIN
 Contact Details c/o OURIMBAH REAL ESTATE PTY LTD A.B.N. (if applicable)
33 PACIFIC HWY Care of Agent Yes No
OURIMBAH 2258 ABN 65003484277 NSW

TENANT [Insert name of tenant(s) and contact details]

Eseroma Waqa KOROVOU & Kelerayani Vatira CEREILAGI
 Mobile: 0404 979 019 E Email: ~~eseroma.korovou@yahoo.com.au~~ Kcereilagi@yahoo.com

OTHER PEOPLE WHO WILL ORDINARILY OCCUPY THE PREMISES:

Jumov KOROVOU - AGED 7 YEARS

Note: By including your email address, you consent to service of any documents, including this agreement and any documents required to be served under or because of this agreement, by way of email.

LANDLORD'S AGENT DETAILS [Insert name of landlord's agent (if any) and contact details]

Licensee OURIMBAH REAL ESTATE PTY LTD
 Trading as OURIMBAH REAL ESTATE PTY LTD A.B.N. 65003484277
 Address 33 PACIFIC HWY
OURIMBAH 2258 ABN 65003484277 NSW Postcode
 Phone 02 4362 1630 Fax 02 4362 2379 Mobile Email enquiries@ourimbahrealestate.com.au

TENANT'S AGENT DETAILS [Insert name of tenant's agent (if any) and contact details]

If appointed, all notices and documents given to the tenant must also be given to the tenant's agent

Name/s _____ A.B.N. _____
 Address _____
 Phone _____ Fax _____ Mobile _____ Postcode _____
 Email _____

TERM OF AGREEMENT

The term of this agreement is: 6 MONTHS ~~weeks~~ / months / years
 starting on 15 / 11 / 2019 and ending on 15 / 05 / 2020 [Cross out if not applicable]

RESIDENTIAL PREMISES

The residential premises are [Insert address]

Address 3/7 KING STREET
 Suburb OURIMBAH State NSW Postcode 2258

The residential premises include: [Include any additional matters, such as a parking space or furniture provided]

TWO BEDROOM VILLA WITH SINGLE LOCK UP GARAGE

Eseroma Korovou

RESIDENTIAL TENANCY AGREEMENT

Note: If the premises include a garage, the garage is provided for the purpose of parking a motor vehicle and not for the storage of goods or personal belongings.

The residential premises **do not include:** *[List anything such as a parking space, garage or storeroom which do not form part of the residential premises]*

RENT

The rent is \$370.00 per WEEK payable in advance starting on 15 /11 /2019 .

The method by which the rent must be paid:

(a) to DIRECT DEPOSIT at ANY BRANCH OF THE BENDIGO BANK by cash or cheque, or

(b) into the following account, or any other account nominated by the landlord:

BSB number: 633-000 Account number: 1108 84707

Account name: OURIMBAH REAL ESTATE OTY LTD TRUST ACCOUNT

Payment reference: KOROVOU3/7 OR 3/7KING

(c) as follows: DIRECT DEBIT FROM TENANTS NOMINATED BANK ACCOUNT

Note. The landlord or landlord's agent must permit the tenant to pay the rent by at least one means for which the tenant does not incur a cost (other than bank or other account fees usually payable for the tenant's transactions) (see clause 4.1) and that is reasonably available to the tenant.

RENTAL BOND *[cross out if there is not going to be a bond]*

A rental bond of \$1480.00 must be paid by the tenant on signing this agreement.
The amount of the rental bond must not be more than 4 weeks rent.

IMPORTANT INFORMATION

MAXIMUM NUMBER OF OCCUPANTS

No more than THREE (3) persons may ordinarily live in the premises at any one time.

URGENT REPAIRS

Nominated tradespeople for urgent repairs and their contact details:

Electrical repairs:	DAVE MORY	Telephone: 0417 064 776
Plumbing repairs:	ROSS MITCHELL	Telephone: 0408 434 849
Other repairs:		Telephone:

WATER USAGE

Will the tenant be required to pay separately for water usage? Yes No If yes, see clauses 11 and 12.

STRATA BY-LAWS

Are there any strata or community scheme by-laws applicable to the residential premises? Yes No If yes, see clause 35 and clause 56.

CONDITION REPORT

A condition report relating to the condition of the premises must be completed by or on behalf of the landlord before or when this agreement is signed.

TENANCY LAWS

The Residential Tenancies Act 2010 and the Residential Tenancies Regulation 2010 apply to this agreement. Both the landlord and the tenant must comply with these laws.

SIGNED BY OURIMBAH REAL ESTATE PTY LTD
ON BEHALF OF LANDLORD

R Allwood

Steven Brown

RESIDENTIAL TENANCY AGREEMENT

RIGHT TO OCCUPY THE PREMISES

1. **The landlord agrees** that the tenant has the right to occupy the residential premises during the tenancy. The residential premises include the additional things (if any) noted under "Residential premises".

COPY OF AGREEMENT

2. **The landlord agrees** to give the tenant:
- 2.1 a copy of this agreement before or when this agreement is signed and given by the tenant to the landlord or a person on the landlord's behalf, and
 - 2.2 a copy of this agreement signed by both the landlord and the tenant as soon as is reasonably practicable.

RENT

3. **The tenant agrees:**
- 3.1 to pay rent on time, and
 - 3.2 to reimburse the landlord for the cost of replacing rent deposit books or rent cards lost by the tenant, and
 - 3.3 to reimburse the landlord for the amount of any fees paid by the landlord to a bank or other authorised deposit-taking institution as a result of funds of the tenant not being available for rent payment on the due date.
4. **The landlord agrees:**
- 4.1 to provide the tenant with at least one means to pay rent for which the tenant does not incur a cost (other than bank fees or other account fees usually payable for the tenant's transactions) and that is reasonably available to the tenant, and
 - 4.2 not to require the tenant to pay more than 2 weeks rent in advance or to pay rent for a period of the tenancy before the end of the previous period for which rent has been paid, and
 - 4.3 not to require the tenant to pay rent by a cheque or other negotiable instrument that is post-dated, and
 - 4.4 to accept payment of unpaid rent after the landlord has given a termination notice on the ground of failure to pay rent if the tenant has not vacated the residential premises, and
 - 4.5 not to use rent paid by the tenant for the purpose of any amount payable by the tenant other than rent, and
 - 4.6 to give a rent receipt to the tenant if rent is paid in person (other than by cheque) and to make a rent receipt available for collection by the tenant or to post it to the residential premises if rent is paid by cheque, and
 - 4.7 to keep a record of rent paid under this agreement and to provide a written statement showing the rent record for a specified period within 7 days of a request by the tenant (unless the landlord has previously provided a statement for the same period).

Note. The landlord and tenant may, by agreement, change the manner in which rent is payable under this agreement.

RENT INCREASES

5. **The landlord and the tenant agree** that the rent cannot be increased after the end of the fixed term (if any) of this agreement or under this agreement unless the landlord gives not less than 60 days written notice of the increase to the tenant. The notice must specify the increased rent and the day from which it is payable.

Note. Section 42 of the *Residential Tenancies Act 2010* sets out the circumstances in which rent may be increased during the fixed term of a residential tenancy agreement. An additional term for this purpose may be included in the agreement.

6. The landlord and the tenant agree:

- 6.1 that the increased rent is payable from the day specified in the notice, and
- 6.2 that the landlord may cancel or reduce the rent increase by a later notice that takes effect on the same day as the original notice, and
- 6.3 that increased rent under this agreement is not payable unless the rent is increased in accordance with this agreement and the *Residential Tenancies Act 2010* or by the Civil and Administrative Tribunal.

RENT REDUCTIONS

7. **The landlord and the tenant agree** that the rent abates if the residential premises:
- 7.1 are destroyed, or become wholly or partly uninhabitable, otherwise than as a result of a breach of this agreement, or
 - 7.2 cease to be lawfully usable as a residence, or
 - 7.3 are compulsorily appropriated or acquired by an authority.
8. The landlord and the tenant may, at any time during this agreement, agree to reduce the rent payable.

PAYMENT OF COUNCIL RATES, LAND TAX, WATER AND OTHER CHARGES

9. **The landlord agrees** to pay:
- 9.1 rates, taxes or charges payable under any Act (other than charges payable by the tenant under this agreement), and
 - 9.2 the installation costs and charges for initial connection to the residential premises of an electricity, water, gas, bottled gas or oil supply service, and
 - 9.3 all charges for the supply of electricity, gas (except bottled gas) or oil to the tenant at the residential premises that are not separately metered, and
 - 9.4 the costs and charges for the supply or hire of gas bottles for the supply of bottled gas at the commencement of the tenancy, and
 - 9.5 all charges (other than water usage charges) in connection with a water supply service to separately metered residential premises, and
 - 9.6 all charges in connection with a water supply service to residential premises that are not separately metered, and
 - 9.7 all charges for the supply of sewerage services (other than for pump out septic services) or the supply or use of drainage services to the residential premises, and
 - 9.8 all charges for the availability of gas to the residential premises if the premises do not have any appliances, supplied by the landlord, for which gas is required and the tenant does not use gas supplied to the premises for any purpose.
10. **The tenant agrees** to pay:
- 10.1 all charges for the supply of electricity, gas (except bottled gas) or oil to the tenant at the residential premises if the premises are separately metered, and
 - 10.2 all charges for the supply of bottled gas to the tenant at the residential premises, and
 - 10.3 all charges for pumping out a septic system used for the residential premises, and
 - 10.4 any excess garbage charges relating to the tenant's use of the residential premises, and
 - 10.5 water usage charges, if the landlord has installed water efficiency measures referred to in clause 11 and the residential premises:

RESIDENTIAL TENANCY AGREEMENT

- 10.5.1 are separately metered, or
 10.5.2 are not connected to a water supply service and water is delivered by vehicle.

11. The landlord agrees that the tenant is not required to pay water usage charges unless:

- 11.1 the landlord gives the tenant a copy of the part of the water supply authority's bill setting out the charges, or other evidence of the cost of water used by the tenant, and
 11.2 the landlord gives the tenant at least 21 days to pay the charges, and
 11.3 the landlord requests payment of the charges by the tenant not later than 3 months after the issue of the bill for the charges by the water supply authority, and
 11.4 the residential premises have the following water efficiency measures:
- 11.4.1 all internal cold water taps and single mixer taps for kitchen sinks or bathroom hand basins on the premises have a maximum flow rate of 9 litres per minute,
 11.4.2 all showerheads have a maximum flow rate of 9 litres per minute,
 11.4.3 there are no leaking taps at the commencement of this agreement or when the water efficiency measures are installed, whichever is the later.

12. The landlord agrees to give the tenant the benefit of, or an amount equivalent to, any rebate received by the landlord for water usage charges payable or paid by the tenant.

POSSESSION OF THE PREMISES

13. The landlord agrees:

- 13.1 to make sure the residential premises are vacant so the tenant can move in on the date agreed, and
 13.2 to take all reasonable steps to ensure that, at the time of signing this agreement, there is no legal reason why the premises cannot be used as a residence for the term of this agreement.

TENANT'S RIGHT TO QUIET ENJOYMENT

14. The landlord agrees:

- 14.1 that the tenant will have quiet enjoyment of the residential premises without interruption by the landlord or any person claiming by, through or under the landlord or having superior title to that of the landlord (such as a head landlord), and
 14.2 that the landlord or the landlord's agent will not interfere with, or cause or permit any interference with, the reasonable peace, comfort or privacy of the tenant in using the residential premises, and
 14.3 that the landlord or the landlord's agent will take all reasonable steps to ensure that the landlord's other neighbouring tenants do not interfere with the reasonable peace, comfort or privacy of the tenant in using the residential premises.

USE OF THE PREMISES BY TENANT

15. The tenant agrees:

- 15.1 not to use the residential premises, or cause or permit the premises to be used, for any illegal purpose, and
 15.2 not to cause or permit a nuisance, and
 15.3 not to interfere, or cause or permit interference, with the reasonable peace, comfort or privacy of neighbours, and
 15.4 not to intentionally or negligently cause or permit any damage to the residential premises, and

- 15.5 not to cause or permit more people to reside in the residential premises than is permitted by this agreement.

16. The tenant agrees:

- 16.1 to keep the residential premises reasonably clean, and
 16.2 to notify the landlord as soon as practicable of any damage to the residential premises, and
 16.3 that the tenant is responsible to the landlord for any act or omission by a person who is lawfully on the residential premises if the person is only permitted on the premises with the tenant's consent and the act or omission would be in breach of this agreement if done or omitted by the tenant, and
 16.4 that it is the tenant's responsibility to replace light globes and batteries for smoke detectors on the residential premises.

Note. Under section 54 of the *Residential Tenancies Act 2010*, the vicarious liability of a tenant for damage to residential premises caused by another person is not imposed on a tenant who is the victim of a domestic violence offence, or a co-tenant who is not a relevant domestic violence offender, if the damage occurred during the commission of a domestic violence offence (within the meaning of that Act).

17. The tenant agrees, when this agreement ends and before giving vacant possession of the premises to the landlord:

- 17.1 to remove all the tenant's goods from the residential premises, and
 17.2 to leave the residential premises as nearly as possible in the same condition, fair wear and tear excepted, as at the commencement of the tenancy, and
 17.3 to leave the residential premises reasonably clean, having regard to their condition at the commencement of the tenancy, and
 17.4 to remove or arrange for the removal of all rubbish from the residential premises, and
 17.5 to make sure that all light fittings on the premises have working globes, and
 17.6 to return to the landlord all keys, and other opening devices or similar devices, provided by the landlord.

LANDLORD'S GENERAL OBLIGATIONS FOR RESIDENTIAL PREMISES

18. The landlord agrees:

- 18.1 to make sure that the residential premises are reasonably clean and fit to live in, and
 18.2 to make sure that all light fittings on the residential premises have working light globes on the commencement of the tenancy, and
 18.3 to keep the residential premises in a reasonable state of repair, considering the age of, the rent paid for and the prospective life of the premises, and
 18.4 not to interfere with the supply of gas, electricity, water, telecommunications or other services to the residential premises (unless the interference is necessary to avoid danger to any person or enable maintenance or repairs to be carried out), and
 18.5 to comply with all statutory obligations relating to the health or safety of the residential premises.

URGENT REPAIRS

19. The landlord agrees to pay the tenant, within 14 days after receiving written notice from the tenant, any reasonable costs (not exceeding \$1,000) that the tenant has incurred for making urgent repairs to the residential premises (of the type set out below) so long as:

- 19.1 the damage was not caused as a result of a breach of this agreement by the tenant, and

RESIDENTIAL TENANCY AGREEMENT

- 19.2** the tenant gives or makes a reasonable attempt to give the landlord notice of the damage, and
- 19.3** the tenant gives the landlord a reasonable opportunity to make the repairs, and
- 19.4** the tenant makes a reasonable attempt to have any appropriate tradesperson named in this agreement make the repairs, and
- 19.5** the repairs are carried out, where appropriate, by licensed or properly qualified persons, and
- 19.6** the tenant, as soon as possible, gives or tries to give the landlord written details of the repairs, including the cost and the receipts for anything the tenant pays for.

Note. The type of repairs that are **urgent repairs** are defined in the *Residential Tenancies Act 2010* and are defined as follows:

- (a) a burst water service,
- (b) an appliance, fitting or fixture that uses water or is used to supply water that is broken or not functioning properly, so that a substantial amount of water is wasted,
- (c) a blocked or broken lavatory system,
- (d) a serious roof leak,
- (e) a gas leak,
- (f) a dangerous electrical fault,
- (g) flooding or serious flood damage,
- (h) serious storm or fire damage,
- (i) a failure or breakdown of the gas, electricity or water supply to the premises,
- (j) a failure or breakdown of any essential service on the residential premises for hot water, cooking, heating, cooling or laundering,
- (k) any fault or damage that causes the premises to be unsafe or insecure.

SALE OF THE PREMISES

20. The landlord agrees:

- 20.1** to give the tenant written notice that the landlord intends to sell the residential premises, at least 14 days before the premises are made available for inspection by potential purchasers, and
- 20.2** to make all reasonable efforts to agree with the tenant as to the days and times when the residential premises are to be available for inspection by potential purchasers.

21. The tenant agrees not to unreasonably refuse to agree to days and times when the residential premises are to be available for inspection by potential purchasers.

22. The landlord and tenant agree:

- 22.1** that the tenant is not required to agree to the residential premises being available for inspection more than twice in a period of a week, and
- 22.2** that, if they fail to agree, the landlord may show the residential premises to potential purchasers not more than twice in any period of a week and must give the tenant at least 48 hours notice each time.

LANDLORD'S ACCESS TO THE PREMISES

23. The landlord agrees that the landlord, the landlord's agent or any person authorised in writing by the landlord, during the currency of this agreement, may only enter the residential premises in the following circumstances:

- 23.1** in an emergency (including entry for the purpose of carrying out urgent repairs),
- 23.2** if the Civil and Administrative Tribunal so orders,
- 23.3** if there is good reason for the landlord to believe the premises are abandoned,

- 23.4** if there is good reason for serious concern about the health of the tenant or any other person on the residential premises and a reasonable attempt has been made to obtain consent to the entry,
- 23.5** to inspect the premises, if the tenant is given at least 7 days written notice (no more than 4 inspections are allowed in any period of 12 months),
- 23.6** to carry out, or assess the need for, necessary repairs, if the tenant is given at least 2 days notice each time,
- 23.7** to carry out, or assess the need for, work relating to statutory health and safety obligations relating to the residential premises, if the tenant is given at least 2 days notice each time,
- 23.8** to show the premises to prospective tenants on a reasonable number of occasions if the tenant is given reasonable notice on each occasion (this is only allowed during the last 14 days of the agreement),
- 23.9** to value the property, if the tenant is given 7 days notice (not more than one valuation is allowed in any period of 12 months),
- 23.10** if the tenant agrees.

24. The landlord agrees that a person who enters the residential premises under clause 23.5, 23.6, 23.7, 23.8 or 23.9 of this agreement:

- 24.1** must not enter the premises on a Sunday or a public holiday, unless the tenant agrees, and
- 24.2** may enter the premises only between the hours of 8.00 a.m. and 8.00 p.m., unless the tenant agrees to another time, and
- 24.3** must, if practicable, notify the tenant of the proposed day and time of entry.

25. The landlord agrees that, except in an emergency (including to carry out urgent repairs), a person other than the landlord or the landlord's agent must produce to the tenant the landlord's or the landlord's agent's written permission to enter the residential premises.

26. The tenant agrees to give access to the residential premises to the landlord, the landlord's agent or any person, if they are exercising a right to enter the residential premises in accordance with this agreement.

ALTERATIONS AND ADDITIONS TO THE PREMISES

27. The tenant agrees:

- 27.1** not to install any fixture or renovate, alter or add to the residential premises without the landlord's written permission, and
- 27.2** not to remove, without the landlord's permission, any fixture attached by the tenant that was paid for by the landlord or for which the landlord gave the tenant a benefit equivalent to the cost of the fixture, and
- 27.3** to notify the landlord of any damage caused by removing any fixture attached by the tenant, and
- 27.4** to repair any damage caused by removing the fixture or compensate the landlord for the reasonable cost of repair.

28. The landlord agrees not to unreasonably refuse permission for the installation of a fixture by the tenant or to a minor alteration, addition or renovation by the tenant.

LOCKS AND SECURITY DEVICES

29. The landlord agrees:

- 29.1** to provide and maintain locks or other security devices necessary to keep the residential premises reasonably secure, and

RESIDENTIAL TENANCY AGREEMENT

- 29.2** to give each tenant under this agreement a copy of the key or opening device or information to open any lock or security device for the residential premises or common property to which the tenant is entitled to have access, and
- 29.3** not to charge the tenant for the cost of providing the copies except to recover the cost of replacement or additional copies, and
- 29.4** not to alter, remove or add any lock or other security device without reasonable excuse (which includes an emergency, an order of the Civil and Administrative Tribunal, termination of a co-tenancy or an apprehended violence order prohibiting a tenant or occupant from having access) or unless the tenant agrees, and
- 29.5** to give each tenant under this agreement a copy of any key or other opening device or information to open any lock or security device that the landlord changes as soon as practicable (and no later than 7 days) after the change.

30. The tenant agrees:

- 30.1** not to alter, remove or add any lock or other security device without reasonable excuse (which includes an emergency, an order of the Civil and Administrative Tribunal, termination of a co-tenancy or an apprehended violence order prohibiting a tenant or occupant from having access) or unless the landlord agrees, and
- 30.2** to give the landlord a copy of the key or opening device or information to open any lock or security device that the tenant changes within 7 days of the change.
- 31.** A copy of a changed key or other opening device need not be given to the other party if the other party agrees not to be given a copy or the Civil and Administrative Tribunal authorises a copy not to be given or the other party is prohibited from access to the residential premises by an apprehended violence order.

TRANSFER OF TENANCY OR SUB-LETTING BY TENANT

32. The landlord and tenant agree that:

- 32.1** the tenant may, with the landlord's written permission, transfer the tenant's tenancy under this agreement or sub-let the residential premises, and
- 32.2** the landlord may refuse permission (whether or not it is reasonable to do so) to the transfer of the whole of the tenancy or sub-letting the whole of the residential premises, and
- 32.3** the landlord must not unreasonably refuse permission to a transfer of part of a tenancy or a sub-letting of part of the residential premises, and
- 32.4** without limiting clause 32.3, the landlord may refuse permission to a transfer of part of the tenancy or to sub-letting part of the residential premises if the number of occupants would be more than is permitted under this agreement or any proposed tenant or sub-tenant is listed on a residential tenancy database or it would result in overcrowding of the residential premises.

Note. Clauses 32.3 and 32.4 do not apply to social tenancy housing agreements.

- 33. The landlord agrees** not to charge for giving permission other than for the landlords reasonable expenses in giving permission.

CHANGE IN DETAILS OF LANDLORD OR LANDLORD'S AGENT

34. The landlord agrees:

- 34.1** if the name and telephone number or contact details of the landlord change, to give the tenant notice in writing of the change within 14 days, and
- 34.2** if the address of the landlord changes (and the landlord does not have an agent), to give the tenant notice in writing of the change within 14 days, and

- 34.3** if the name, telephone number or business address of the landlord's agent changes or the landlord appoints an agent, to give the tenant notice in writing of the change or the agent's name, telephone number and business address, as appropriate, within 14 days, and
- 34.4** if the landlord or landlord's agent is a corporation and the name or business address of the corporation changes, to give the tenant notice in writing of the change within 14 days.

COPY OF CERTAIN BY-LAWS TO BE PROVIDED

[Cross out if not applicable]

- 35.** The landlord agrees to give to the tenant within 7 days of entering into this agreement a copy of the by-laws applying to the residential premises if they are premises under the *Strata Schemes Management Act 2015*, the *Strata Schemes Development Act 2015*, the *Community Land Development Act 1989* or the *Community Land Management Act 1989*.

MITIGATION OF LOSS

- 36. The rules of law** relating to mitigation of loss or damage on breach of a contract apply to a breach of this agreement. (For example, if the tenant breaches this agreement the landlord will not be able to claim damages for loss which could have been avoided by reasonable effort by the landlord.)

RENTAL BOND

[Cross out this clause if no rental bond is payable]

- 37. The landlord agrees** that where the landlord or the landlord's agent applies to the Rental Bond Board or the Civil and Administrative Tribunal for payment of the whole or part of the rental bond to the landlord, then the landlord or the landlord's agent will provide the tenant with details of the amount claimed and with copies of any quotations, accounts and receipts that are relevant to the claim and a copy of a completed condition report about the residential premises at the end of the residential tenancy agreement.

SMOKE ALARMS

- 38. The landlord agrees** to ensure that smoke alarms are installed and maintained in the residential premises in accordance with section 146A of the *Environmental Planning and Assessment Act 1979* if that section requires them to be installed in the premises.
- 39. The landlord and tenant each agree** not to remove or interfere with the operation of a smoke alarm installed on the residential premises unless they have a reasonable excuse to do so.

SWIMMING POOLS

[Cross out this clause if there is no swimming pool]

- 40. The landlord agrees** to ensure that the requirements of the *Swimming Pools Act 1992* have been complied with in respect of the swimming pool on the residential premises.

[Cross out the following clause if there is no swimming pool or the swimming pool is situated on land in a strata scheme (within the meaning of the Strata Schemes Management Act 2015) or in a community scheme (within the meaning of the Community Land Development Act 1989) and that strata or community scheme comprises more than 2 lots]

- 40A. The landlord agrees** to ensure that at the time that this residential tenancy agreement is entered into:

- 40A.1** the swimming pool on the residential premises is registered under the *Swimming Pools Act 1992* and has a valid certificate of compliance under that Act or a relevant occupation certificate within the meaning of that Act, and
- 40A.2** a copy of that valid certificate of compliance or relevant occupation certificate is provided to the tenant.

RESIDENTIAL TENANCY AGREEMENT

LOOSE-FILL ASBESTOS INSULATION

40B. The Landlord agrees:

- 40B.1** if, at the time that this residential tenancy agreement is entered into, the premises have been and remain listed on the LFAI Register, the tenant has been advised in writing by the landlord that the premises are listed on that Register, or
- 40B.2** if, during the tenancy, the premises become listed on the LFAI Register, to advise the tenant in writing, within 14 days of the premises being listed on the Register, that the premises are listed on the Register.

ADDITIONAL TERMS

[Additional terms may be included in this agreement if:

- (a) both the landlord and tenant agree to the terms, and
- (b) they do not conflict with the Residential Tenancies Act 2010, the Residential Tenancies Regulation 2010 or any other Act, and
- (c) they do not conflict with the standard terms of this agreement.]

[ANY ADDITIONAL TERMS ARE NOT REQUIRED BY LAW AND ARE NEGOTIABLE]

ADDITIONAL TERM - BREAK FEE

[Cross out this clause if not applicable and, if not applicable, note clauses 54.2(a) and 54.2(c)]

41. The tenant agrees that, if the tenant ends the residential tenancy agreement before the end of the fixed term of the agreement, the tenant must pay a break fee of the following amount:

- 41.1** if the fixed term is for 3 years or less, 6 weeks rent if less than half of the term has expired or 4 weeks rent in any other case, or
- 41.2** if the fixed term is for more than 3 years,

\$

This clause does not apply if the tenant terminates the residential tenancy agreement early for a reason that is permitted under the *Residential Tenancies Act 2010*.

Note. Permitted reasons for early termination include destruction of residential premises, breach of the agreement by the landlord, an offer of social housing or a place in an aged care facility, and being in circumstances of domestic violence. Also refer to clauses 52, 53, 54 and 55 for termination of this agreement.

Section 107 of the *Residential Tenancies Act 2010* regulates the rights of the landlord and tenant under this clause.

42. The landlord agrees that the compensation payable by the tenant for ending the residential tenancy agreement before the end of the fixed term is limited to the amount specified in clause 41 and any occupation fee payable under the *Residential Tenancies Act 2010* for goods left on the residential premises.

ADDITIONAL TERM - PETS

- 43. The tenant agrees** not to keep animals on the residential premises without first obtaining the written consent of the landlord and, if applicable, the body corporate, community association or board of directors.
- 44. The landlord agrees** that the tenant may keep the following animals on the residential premises unless otherwise prohibited by a strata by-law, community title rule, company title rule and/or management statement, or under a law relating to health or other applicable law:

NO PETS PERMITTED

Ra *SK KC.*

45. The tenant agrees to:

- 45.1** have the carpet professionally cleaned and to have the residential premises treated by a professional pest control provider/entity if animals have been kept on the residential premises during the tenancy;
- 45.2** repair any damage caused by animals kept on the residential premises;
- 45.3** upon request, and in the form of evidence elected, by the landlord or landlord's agent, provide to the landlord or the landlord's agent (as the case may be) evidence that the tenant has complied with clauses 45.1 and 45.2 of this agreement; and
- 45.4** indemnify the landlord in respect of all claims arising out of or in connection with any damage, costs or personal injuries caused or contributed to by:
- (a) any animals kept by the tenant on the residential premises; and
- (b) any animals moving, or being moved by someone, across the residential premises and any common areas.

ADDITIONAL TERM - AGREEMENT TO USE PREVIOUS CONDITION REPORT

46. The landlord and tenant agree that the condition report included in a residential tenancy agreement entered into by the tenant and dated / / (insert a date if the landlord and tenant agree to this clause) forms part of this agreement.

ADDITIONAL TERM - TENANT'S CARE AND USE OF THE RESIDENTIAL PREMISES

- 47.** Further to clauses 15 and 16 and subject to any applicable by-law, **the tenant agrees:**
- 47.1** to use the residential premises for residential purposes only;
- 47.2** not to use, advertise for use, sub-let, licence, transfer or otherwise part with possession of the whole or any part of the residential premises for the purpose of giving a person the right to occupy the residential premises for the purpose of a holiday, without the prior written consent of the landlord where such consent may be refused in the landlord's absolute discretion;
- 47.3** to clean the residential premises regularly with special attention to the kitchen, bathroom and appliances;
- 47.4** to put nothing down any sink, toilet or drain likely to cause obstruction or damage;
- 47.5** to wrap up and place garbage in a suitable container;
- 47.6** to regularly mow the lawns and keep the grounds and garden tidy and free of weeds and rubbish and maintain them in their condition, fair wear and tear excepted, as at the commencement of this agreement;
- 47.7** to take special care of the items let with the residential premises including any furniture, furnishings and appliances;
- 47.8** to do no decorating that involves painting, marking or defacing the residential premises or fixing posters without the prior written consent of the landlord or an order of the Civil and Administrative Tribunal;
- 47.9** to ensure that nothing is done that may prejudice any insurance policy or increase the premium payable under any insurance policy held by the landlord in relation to the residential premises and to ensure that nothing is done on the residential premises which may expose the owner to any claims or liability or which might give rise to an insurance claim;
- 47.10** to notify the landlord promptly of any infectious disease or the presence of rats, cockroaches, fleas or other pests;

RESIDENTIAL TENANCY AGREEMENT

- 47.11** to ventilate, in an adequate and timely manner and, if applicable, without any alteration or addition to the common property, all rooms and areas in the residential premises and to prevent the growth of mould;
- 47.12** not to remove, alter or damage any water efficiency measure installed in the residential premises;
- 47.13** not to store rubbish, unregistered vehicles, any inflammable, dangerous or hazardous chemical, liquid or gas (with the exception of petrol or gas stored in the fuel tank of any registered motor vehicle) or other inflammable, dangerous or hazardous material on the residential premises, and storage of any items on the residential premises is at the tenant's own risk; and
- 47.14** to take out and bring in, in accordance with the scheduled garbage collection days, and to keep clean, all bins that are supplied with the residential premises and to pay the cost of repair or replacement of any bins that become damaged, lost or stolen (if not repaired or replaced at the cost of the relevant authority) whilst the tenant is in occupation of the residential premises.

ADDITIONAL TERM - TELECOMMUNICATIONS SERVICES

48. The tenant agrees:

- 48.1** to leave, in the same manner of connection or operation, any telephone service installed in the residential premises at the commencement of this agreement; and
- 48.2** the availability of telephone or fax lines, internet services, analogue, digital or cable television (and the adequacy of such services); are the sole responsibility of the tenant and the tenant should make their own enquiries as to the availability and adequacy of such services before executing this agreement. The landlord does not warrant that any telephone or fax plugs, antenna sockets or other such sockets or service points located in the residential premises are serviceable, or will otherwise meet the requirements of the tenant, and tenants must rely upon their own enquiries. The landlord is not obliged to install any antenna, plugs or sockets including but not limited to any digital aerials or antennas or to carry out any upgrades in respect of television or internet reception on the residential premises.

ADDITIONAL TERM - RENT AND RENTAL BOND

49. The tenant agrees:

- 49.1** to pay the rent on or before the day which the term of this agreement begins; and
- 49.2** not to apply any rental bond towards payment of the rent without the prior written consent of the landlord.

50. The landlord and the tenant may, by agreement, change the manner in which rent is payable under this agreement.

ADDITIONAL TERM - OCCUPANTS

51. The tenant agrees:

- 51.1** not to part with possession other than in accordance with the provisions of this agreement or the *Residential Tenancies Act 2010*; and
- 51.2** to ensure that occupants and other persons who come on to the residential premises with the tenant's consent comply with the conditions of this agreement.

ADDITIONAL TERM - TERMINATION

52. The tenant acknowledges that a notice of termination does not by itself end the tenant's obligations under this agreement.

53. The tenant agrees:

53.1 upon termination of this agreement, to:

- promptly and peacefully deliver up vacant possession of the residential premises to the landlord by the date specified in the termination notice or otherwise in accordance with the *Residential Tenancies Act 2010*;
- promptly notify the landlord or the landlord's agent of the tenant's forwarding address; and
- comply with its obligations in clause 17 of this agreement; and

53.2 that the tenant's obligations under this agreement (including to pay rent and other amounts payable to the landlord pursuant to clause 54.2) continue until such time as the tenant has provided vacant possession of the residential premises, left them in the condition required under this agreement and returned to the landlord or the landlord's agent all keys, access cards, locks and other opening devices and security items.

54. Notwithstanding any termination of the agreement, the tenant acknowledges and agrees that:

- 54.1** an application may be made to the Civil and Administrative Tribunal if the tenant does not vacate when required or otherwise does not comply with this agreement;
- 54.2** if the tenant terminates this agreement before the expiry of the fixed term and if clauses 41 and 42 regarding the break fee are deleted (and, therefore, do not apply), subject to the parties' obligations to mitigate their losses:
- the tenant must:
 - reimburse the landlord for costs, fees and other charges and expenses in connection with such termination; and
 - pay rent or compensation for an amount equivalent to rent until such time as the landlord finds a suitable replacement tenant or until the date on which the fixed term of the agreement has expired (whichever occurs first), and the parties agree that this clause 54.2(a) does not apply if the tenant terminates the residential tenancy agreement early for a reason permitted under the *Residential Tenancies Act 2010*;
 - the tenant must comply with the requirements of clause 53 before the expiration of the fixed term of this agreement; and
 - the landlord is under no obligation to advertise the residential premises, arrange any inspection of the residential premises by prospective tenants or take any other action to lease the residential premises until vacant possession is provided by the tenant; and
- 54.3** the landlord is entitled to claim damages for loss of bargain in the event of a termination of this agreement on the grounds of a breach.

55. The landlord and the tenant agree that:

- 55.1** any action by the landlord or the tenant to terminate this agreement shall not affect any claim for compensation in respect of a breach of this agreement;
- 55.2** the acceptance of or demand for rent or other money by the landlord after service of a termination notice for breach does not operate as a waiver of that notice nor does it evidence the creation of a new tenancy; and
- 55.3** the landlord's entitlement to claim damages for loss of bargain pursuant of clause 54.3 and the tenant's obligation to pay rent as and when it falls due are fundamental and essential terms of this agreement.

RESIDENTIAL TENANCY AGREEMENT

Note: Examples of where a fixed term agreement can be ended are where a party has breached the agreement (in which case the notice period is not less than 14 days) or where the rent has remained unpaid in breach of the agreement for not less than 14 days. Examples of where a periodic agreement can be ended are where a contract for sale of land requiring vacant possession has been exchanged (in which case the notice period is not less than 30 days), a party has breached the agreement (in which case the notice period is not less than 14 days) or where the rent has remained unpaid in breach of the agreement for not less than 14 days.

Note: If the tenant breaches this agreement the landlord should refer to section 87(2) of the *Residential Tenancies Act 2010*.

ADDITIONAL TERM - STATUTES, STRATA BY-LAWS, RULES AND SPECIAL CONDITIONS FOR FLATS

56. The tenant acknowledges and agrees:

- 56.1** to observe all relevant statutes, statutory regulations, strata by-laws, company title rules and community title rules relating to health, safety, noise and other housing standards with respect to the residential premises;
- 56.2** where the residential premises are subject to the *Strata Schemes Management Act 2015*, the *Strata Schemes Development Act 2015*, the *Community Land Development Act 1989* or the *Community Land Management Act 1989*, to observe and comply with any applicable strata by-laws and / or management statements and any applicable law;
- 56.3** where the residential premises are a flat (not subject to the *Strata Schemes Management Act 2015*, the *Strata Schemes Development Act 2015*, the *Community Land Development Act 1989* or the *Community Land Management Act 1989*), to observe and comply with any applicable law and the special conditions contained in Schedule A of this agreement and any other special conditions as notified to the tenant from time to time; and
- 56.4** that, at the tenant's cost, the owners corporation or strata managing agent may dispose of abandoned goods, perishable goods or rubbish left on common property.

ADDITIONAL TERM - SWIMMING POOLS

(This clause does not apply when there is no pool on the residential premises)

- 57. Unless otherwise agreed by the landlord and tenant in writing, the tenant agrees:**
- 57.1** to vacuum, brush and clean the pool, backwash the filter and empty the leaf basket(s) regularly keeping them free from leaf litter and other debris;
- 57.2** to have the pool water tested once a month at a pool shop and to purchase and use the appropriate chemicals to keep the water clean and clear;
- 57.3** to keep the water level above the filter inlet at all times;
- 57.4** to notify the landlord or the landlord's agent as soon as practicable of any problems with the pool or equipment, safety gate, access door, fence or barrier;
- 57.5** not to interfere with the operation of any pool safety gate, access door, fence or barrier including not propping or holding open any safety gate or access door, nor leaving any item or object near a pool safety gate, access door, fence or barrier which would aid or allow access by children to the pool area or allow children to climb the pool safety gate, access door, fence or barrier; and
- 57.6** to ensure that the pool safety gate or access door is self-closing at all times.

ADDITIONAL TERM – RENT INCREASES DURING THE FIXED TERM (for a fixed term of **less than 2 years**):

58. By completing this clause, **the parties agree** that the rent will be increased during the fixed term of the agreement as follows:

58.1 the rent will be increased to

\$		per	
	on	/ /	; and
to \$		per	
	on	/ /	; or

58.2 the rent increase can be calculated by the following method (set out details):

Note: The rent payable under a residential tenancy agreement may be increased only if the tenant is given written notice by the landlord or the landlord's agent specifying the increased rent and the day from which it is payable, and the notice is given at least 60 days before the increased rent is payable.

Notice of a rent increase must be given by a landlord or landlord's agent even if details of the rent increase are set out in the residential tenancy agreement.

ADDITIONAL TERM – RENT INCREASES DURING THE FIXED TERM (for a fixed term of **2 years or more**):

59. By completing this clause, **the parties agree** that the rent will be increased during the fixed term of the agreement as follows:

59.1 the rent will be increased to

\$		per	
	on	/ /	; and
to \$		per	
	on	/ /	; or

59.2 the rent increase can be calculated by the following method (set out details):

Note: The rent payable under a residential tenancy agreement may be increased only if the tenant is given written notice by the landlord or the landlord's agent specifying the increased rent and the day from which it is payable, and the notice is given at least 60 days before the increased rent is payable.

Notice of a rent increase must be given by a landlord or landlord's agent even if details of the rent increase are set out in the residential tenancy agreement.

Note: The rent payable under a fixed term agreement for a fixed term of 2 years or more must not be increased more than once in any period of 12 months, and may be increased whether or not the agreement sets out the amount of the increase or the method of calculating the increase.



ADDITIONAL TERM - CONDITION REPORT FORMS PART OF THIS AGREEMENT

60. For avoidance of doubt:

- 60.1 a condition report which accompanies this agreement, forms part of this agreement;
- 60.2 a condition report that is signed by both the landlord and the tenant is presumed to be a correct statement, in the absence of evidence to the contrary, of the state of repair or general condition of the residential premises on the day specified in the report; and
- 60.3 if the tenant fails to return the condition report to the landlord or the landlord's agent within 7 days of being provided with the landlord's signed condition report then the tenant is deemed to have accepted the landlord's signed condition report and that report forms part of this agreement.

ADDITIONAL TERM - ADDITIONAL TENANT OBLIGATIONS

61. The tenant agrees:

- 61.1 to reimburse the landlord, within 30 days of being requested to do so, for:
- any call out fees payable where the call out has been arranged with the tenant and the tenant has failed to provide access to the residential premises for any reason, preventing the relevant service from taking place;
 - any cost or expense of any kind incurred by the landlord to replace or fix an item, fixture or fitting in or on the residential premises that was required to be replaced or fixed as a result of a fire audit or fire inspection, provided that the item, fixture or fitting needed replacing or fixing due to the activities carried out by the tenant in or on the residential premises (including, without limitation, creating holes in, or attaching hooks to, fire safety doors); and
 - any fine, penalty or costs of any recovery action incurred by the landlord arising out of or in connection with the failure of a body corporate, community association or company to comply with a statutory requirement (including, without limitation, the lodgement of an annual fire safety statement) if that failure was caused or contributed to by the tenant;
- 61.2 to notify the landlord or the landlord's agent immediately if any smoke detector or smoke alarm in the residential premises is not working properly so that the landlord can attend to the landlord's obligation referred to in clause 38 of this agreement;
- 61.3 to pay any call out fees payable to the fire brigade or other authorities which become payable in the event that a smoke alarm fitted to the residential premises is activated by activities carried out by the tenant on the residential premises, including but not limited to burning food; and
- 61.4 where the residential premises are subject to the *Strata Schemes Management Act 2015* or the *Strata Schemes Development Act 2015* to immediately notify the landlord or the landlord's agent of:
- any windows in the residential premises that do not have any locks or other window safety devices; or
 - any locks or other window safety devices in the residential premises that are non-compliant with legislation or need repairing,

so that the landlord or landlord's agent can ensure compliance with section 118 of the *Strata Schemes Management Act 2015* with respect to window safety devices.

ADDITIONAL TERM - TENANCY DATABASES

62. The landlord or the landlord's agent advises and the tenant acknowledges and agrees that the tenant's personal information may be collected, used and disclosed for the purpose of listing the tenant on a tenancy database as permitted by, and in accordance with, the provisions of the *Residential Tenancies Act 2010*.

ADDITIONAL TERM - GARAGE, STORAGE CAGE, OPEN CAR SPACE OR OTHER STORAGE FACILITY

[This clause does not apply if there is no garage, storage cage, open car space or other storage facility on the residential premises]

63. The landlord gives no undertaking as to the security and/or waterproofing of any garage, storage cage, open car space or any other storage facility on the residential premises and accepts no liability for any damage to such garage, storage cage, open car space or other storage facility or to anything stored therein.

ADDITIONAL TERM - DETAILS OF TENANT AND TENANT'S AGENT

64. The tenant agrees to notify the landlord or the landlord's agent, in writing within 14 days, of any changes to the nominated contact details of the tenant or the tenant's agent, including those specified in this agreement.

ADDITIONAL TERM - TENANT'S REFUSAL OF ACCESS

65. Where the tenant has been provided with the requisite notice pursuant to clause 23.8 and the tenant has refused access to the residential premises preventing prospective tenants from inspecting them, the tenant acknowledges and agrees that the landlord is entitled to claim damages for loss of bargain in the event the landlord is unable to secure a future tenant as a result of the tenant's refusal to allow access to the residential premises.

66. The tenant agrees that the landlord and the landlord's agent are authorised to use the office set of keys to access the residential premises for the purpose of carrying out an inspection pursuant to clause 23.

ADDITIONAL TERM - PRIVACY POLICY

67. The *Privacy Act 1988* (Cth) (the Act) allows certain information about the tenant referred to in this agreement to be collected, used and disclosed for the purpose for which it was collected, and otherwise in accordance with the Act. This Privacy Policy does not form part of this agreement and only applies to the extent that the landlord collects, uses and discloses personal information and is required by the Act to comply with the requirements of the Act. If the landlord appoints an agent to act for the landlord, then this Privacy Policy will apply to the landlord's agent's collection, use and disclosure of personal information on behalf of the landlord.

The landlord may amend, or amend and restate, this Privacy Policy from time to time and may subsequently notify the tenant of any changes to this Privacy Policy by written notification to the tenant. Any change to this Privacy Policy takes effect on the date of that written notification.

RESIDENTIAL TENANCY AGREEMENT

The personal information the tenant provides in connection with this agreement or collected from other sources is necessary for the landlord and (if appointed) the landlord's agent to:

- (a) identify and verify the tenant's identity;
- (b) process and assess any application received in relation to the lease of the residential premises;
- (c) assess the tenant's ability to meet their financial and other obligations under this agreement;
- (d) manage this agreement and the residential premises including (without limitation) the collection of rent and the preparation of required statements of accounts;
- (e) contact and liaise with goods and services providers as instructed by the tenant and to provide those providers with the tenant's personal information;
- (f) comply with any applicable law;
- (g) liaise and exchange information with the tenant and the legal and other advisors of the tenant, landlord and (if appointed) the landlord's agent in relation to or in connection with this agreement;
- (h) negotiate the lease for the residential premises;
- (i) process any payment (including, without limitation, the exchange of personal information with the relevant payment provider, where necessary); and
- (j) comply with any dispute resolution process.

If the personal information is not provided by the tenant, the landlord and (if appointed) the landlord's agent may not be able to carry out the steps described above.

Personal information collected about the tenant may be disclosed by the landlord or (if appointed) the landlord's agent for the purpose for which it was collected, to other parties including to the landlord (if the landlord's agent is appointed), the landlord's mortgagee or head-lessor (in either case, if any), the legal and other advisors of the tenant, landlord and (if appointed) the landlord's agent, referees, valuers, other agents, Courts and applicable tribunals, third party operators of tenancy and other databases, other third parties instructed by the tenant (including, without limitation, goods, and services providers), as required by any applicable law and to any prospective or actual purchaser of the residential premises including to their prospective or actual mortgagee (if any). Personal information held by tenancy databases and relevant agencies may also be requested by and disclosed to the landlord and/or the landlord's agent. The landlord and (if appointed) the landlord's agent will take reasonable precautions to protect the personal information they hold in relation to the tenant from misuse, loss, and unauthorised access, modification or disclosure.

Further, if the tenant applies for the lease of the residential premises via any third party letting business, including any online letting businesses, then the tenant will have consented to the disclosure of its personal information by that business to the landlord and (if appointed) the landlord's agent. The tenant consents to the landlord and (if appointed) the landlord's agent receiving personal information from the relevant online letting business for the purposes specified in this Privacy Policy.

If the tenant fails to comply with its obligations under this agreement, then that fact and other relevant personal information collected about the tenant during the term of this agreement may also be disclosed to third party operators of tenancy and other databases, other agents, Courts and relevant tribunals.

The landlord and (if appointed) the landlord's agent may also use the tenant's information including personal information for marketing and research purposes to inform the tenant of products and services provided by the landlord and (if appointed) the landlord's agent, which the landlord and (if appointed) the landlord's agent consider may be of value or interest to the tenant, unless the tenant tells the landlord or (if appointed) the landlord's agent (see opt out option below) or has previously told the landlord or (if appointed) the landlord's agent not to. If the tenant **does not** wish to receive any information about such products and services then please tick this box: or otherwise notify the landlord and/or landlord's agent using the contact details of the landlord and/or landlord's agent (as applicable) set out earlier in this agreement.

The tenant has the right to request access to any personal information held by the landlord and (if appointed) the landlord's agent which relates to them, unless the landlord or (if appointed) the landlord's agent is permitted by law (including the Act) to withhold that information. If the Act applies to the landlord and the landlord is an 'organisation' (as defined under the Act) then it is entitled to charge a reasonable fee where access to personal information is provided (no fee may be charged for making an application to access personal information). If an agent is appointed by the landlord, it is entitled to charge a reasonable fee where access to personal information is provided (no fee may be charged for making an application to access personal information). Any requests for access to the tenant's personal information should be made in writing to the landlord or (if appointed) the landlord's agent at the contact details included in this agreement. The tenant has the right to request the correction of any personal information which relates to the tenant that is inaccurate, incomplete or out-of-date.

By signing this agreement, **the tenant acknowledges** that it has read and understands the terms of this Privacy Policy and agrees to those terms and the permissions to collect, use and disclose personal information, and **the tenant authorises** the landlord and (if appointed) the landlord's agent to collect, use and obtain, in accordance with the Act, their personal information for the purposes specified in this Privacy Policy.

ADDITIONAL TERM - ADDITIONAL TERMS AND CONDITIONS

68. The landlord and tenant acknowledge that:

- 68.1 the landlord and tenant are permitted to agree on additional terms and conditions of this agreement and to include them in an annexure at the end of this agreement; and
- 68.2 the additional terms and conditions may be included in this agreement only if:
 - (a) they do not contravene the *Residential Tenancies Act 2010* (NSW), the *Residential Tenancies Regulation 2010* (NSW) or any other Act; and
 - (b) they are not inconsistent with the standard terms and conditions of this agreement.

69. The landlord and tenant jointly and severally indemnify and hold harmless: The Real Estate Institute of New South Wales (REINSW) in relation to any actions, proceedings, claims, losses, costs and damages which REINSW suffers, incurs or becomes liable for and which arise directly or indirectly from or are in connection with any additional terms and/or conditions that are included in an annexure to this agreement.

SCHEDULE A
SPECIAL CONDITIONS - FLATS
Special Condition 1 - Vehicles

The tenant must not park or stand any motor or other vehicle on common area, or permit a motor vehicle to be parked or stood on common area, except with the prior written approval of the landlord or as permitted by a sign authorised by the landlord.

Special Condition 2 - Damage to lawns and plants on the common areas

The tenant must not, except with the prior written approval of the landlord:

- (a) damage any lawn, garden, tree, shrub, plant or flower being part of or situated on the common area, or
- (b) use for his or her own purposes as a garden any portion of the common area.

Special Condition 3 - Obstruction of common areas

The tenant must not obstruct lawful use of common areas by any person except on a temporary and non-recurring basis.

Special Condition 4 - Noise

The tenant, or any invitee of the tenant, must not create any noise in the flat or the common area likely to interfere with the peaceful enjoyment of the owner or occupier of another flat or of any person lawfully using the common area.

Special Condition 5 - Behaviour of tenants and invitees

- (a) The tenant, or any invitee of the tenant, when on the common area must be adequately clothed and must not use language or behave in a manner likely to cause offence or embarrassment to the owner or occupier of another lot or to any person lawfully using the common area.
- (b) The tenant must take all reasonable steps to ensure that their invitees:
 - (i) do not behave in a manner likely to interfere with the peaceful enjoyment of the owner or occupier of another flat or any person lawfully using the common area; and
 - (ii) without limiting paragraph (b)(i), comply with Special Condition 5(a).

Special Condition 6 - Children playing on common areas in building

Any child for whom the tenant is responsible may play on any area of the common area that is designated by the landlord for that purpose but may only use an area designated for swimming while under adult supervision. The tenant must not permit any child of whom the tenant is responsible, unless accompanied by an adult exercising effective control, to be or to remain on the common area that is a laundry, car parking area or other area of possible danger or hazard to children.

Special Condition 7 - Smoke penetration

The tenant, and any invitee of the tenant, must not smoke tobacco or any other substance on the common area, except:

- (a) in an area designated as a smoking area by the landlord, or
- (b) with the written approval of the landlord.

The tenant who is permitted under this Special Condition to smoke tobacco or any other substance on common area must ensure that the smoke does not penetrate to any other flat. The tenant must ensure that smoke caused by the smoking of tobacco or any other substance by the tenant, or any invitee of the tenant, in the flat does not penetrate to the common area or any other flat.

Special Condition 8 - Preservation of fire safety

The tenant must not do any thing or permit any invitees to do any thing in the flat or common area that is likely to affect the operation of fire safety devices in the parcel or to reduce the level of fire safety in the flats or common areas.

Special Condition 9 - Storage of inflammable, dangerous or hazardous liquids and other substances and materials

- (a) The tenant must not, except with the prior written approval of the landlord, use or store in the flat, garage or carport or on the common area any inflammable, dangerous or hazardous chemical, liquid or gas or other inflammable, dangerous or hazardous material.
- (b) This Special Condition does not apply to chemicals, liquids, gases or other material used or intended to be used for domestic purposes, or any chemical, liquid, gas or other material in a fuel tank of a motor vehicle or internal combustion engine.

Special Condition 10 - Appearance of flat

- (a) The tenant must not, without the prior written approval of the landlord, maintain within the flat anything visible from outside the flat that, viewed from outside the flat, is not in keeping with the rest of the building.
- (b) This Special Condition does not apply to the hanging of any clothing, towel, bedding or other article of a similar type in accordance with Special Condition 12.

Special Condition 11 - Cleaning windows and doors

- (a) Except in circumstances referred to in Special Condition 11(b), the tenant is responsible for cleaning all interior and exterior surfaces of glass in windows and doors on the boundary of the flat, including so much as is common area.
- (b) The landlord is responsible for cleaning regularly all exterior surfaces of glass in windows and doors that cannot be accessed by the tenant safely or at all.

Special Condition 12 - Hanging out of washing

The tenant may hang any washing on any lines provided by the landlord for that purpose. The tenant may hang washing on any part of the flat other than over the balcony railings. In each case, the washing may only be hung for a reasonable period. In this Special Condition, "washing" includes any clothing, towel, bedding or other article of a similar type.

Special Condition 13 - Disposal of waste - bins for individual flats (applicable where individual flats have bins)

- (a) The tenant must:
 - (i) not deposit or throw on the common area any rubbish, dirt, dust or other material or discarded item except with the prior written approval of the landlord;
 - (ii) not deposit in a toilet, or otherwise introduce or attempt to introduce into the plumbing system, any item that is not appropriate for any such disposal (for example, a disposable nappy);
 - (iii) comply with all reasonable directions given by the landlord as to the disposal and storage of waste (including the cleaning up of spilled waste) on the common area;
 - (iv) comply with the local council's guidelines for the storage, handling, collection and disposal of waste;
 - (v) maintain bins for waste within the flat, or on any part of the common area that is authorised by the landlord, in clean and dry condition and appropriately covered;
 - (vi) not place any thing in the bins of the owner or occupier of any other flat except with the permission of that owner or occupier;
 - (vii) place the bins within an area designated for collection by the landlord not more than 12 hours before the time at which waste is normally collected and, when the waste has been collected, must promptly return the bins to the flat or other area authorised for the bins; and
 - (viii) notify the local council of any loss of, or damage to, bins provided by the local council for waste.

- (b) The landlord may give directions for the purposes of this Special Condition by posting signs on the common area with instructions on the handling of waste that are consistent with the local council's requirements or giving notices in writing to tenants.
- (c) In this Special Condition, "bin" includes any receptacle for waste and "waste" includes garbage and recyclable material.

**Special Condition 14 - Disposal of waste - shared bins
(applicable where bins are shared by flats)**

- (a) The tenant must:
 - (i) not deposit or throw on the common area any rubbish, dirt, dust or other material or discarded item except with the prior written approval of the landlord;
 - (ii) not deposit in a toilet, or otherwise introduce or attempt to introduce into the plumbing system, any item that is not appropriate for any such disposal (for example, a disposable nappy);
 - (iii) comply with all reasonable directions given by the landlord as to the disposal and storage of waste (including the cleaning up of spilled waste) on common area; and
 - (iii) comply with the local council's guidelines for the storage, handling, collection and disposal of waste.
- (b) The landlord may give directions for the purposes of this Special Condition by posting signs on the common area with instructions on the handling of waste that are consistent with the local council's requirements or giving notices in writing to tenants.
- (c) In this Special Condition, "bin" includes any receptacle for waste and "waste" includes garbage and recyclable material.

Special Condition 15 - Change in use or occupation of flat to be notified

- (a) The tenant must notify the landlord if the tenant changes the existing use of the flat.
- (b) Without limiting Special Condition 15(a), the following changes of use must be notified:
 - (i) a change that may affect the insurance premiums for the landlord (for example, if the change of use results in a hazardous activity being carried out in the flat, or results in the flat being used for commercial or industrial purposes rather than residential purposes); and
 - (i) a change to the use of the flat for short-term or holiday letting.
- (c) The notice must be given in writing at least 21 days before the change occurs or a lease or sublease commences.

Special Condition 16 - Compliance with planning and other requirements

The tenant must ensure that the flat is not used for any purpose that is prohibited by law and that the flat is not occupied by more persons than are allowed by law to occupy the flat.

NOTES.**1. Definitions**

In this agreement:

landlord means the person who grants the right to occupy residential premises under this agreement, and includes a successor in title to the residential premises whose interest is subject to that of the tenant.

landlord's agent means a person who acts as the agent of the landlord and who (whether or not the person carries on any other business) carries on business as an agent for:

- (a) the letting of residential premises, or
- (b) the collection of rents payable for any tenancy of residential premises.

LFAI Register means the register of residential premises that contain or have contained loose-fill asbestos insulation that is required to be maintained under Division 1A of Part 8 of the *Home Building Act 1989*.

rental bond means money paid by the tenant as security to carry out this agreement.

residential premises means any premises or part of premises (including any land occupied with the premises) used or intended to be used as a place of residence.

tenancy means the right to occupy residential premises under this agreement.

tenant means the person who has the right to occupy residential premises under this agreement, and includes the person to whom such a right passes by transfer or operation of the law and a sub-tenant of the tenant.

2. Continuation of tenancy (if fixed term agreement)

Once any fixed term of this agreement ends, the agreement continues in force on the same terms as a periodic agreement unless the agreement is terminated by the landlord or the tenant in accordance with the *Residential Tenancies Act 2010* (see notes 3 and 4). Clause 5 of this agreement provides for rent to be able to be increased if the agreement continues in force.

3. Ending a fixed term agreement

If this agreement is a fixed term agreement it may be ended by the landlord or the tenant by giving written notice of termination. The notice may be given at any time up until the end of the fixed term but cannot take effect until the term ends. The landlord must give at least 30 days notice and the tenant must give at least 14 days notice.

4. Ending a periodic agreement

If this agreement is a periodic agreement it may be ended by the landlord or the tenant by giving written notice of termination. The notice may be given at any time. The landlord must give at least 90 days notice and the tenant must give at least 21 days notice.

5. Other grounds for ending agreement

The *Residential Tenancies Act 2010* also authorises the landlord and tenant to end this agreement on other grounds. The grounds for the landlord include sale of the residential premises, breach of this agreement by the tenant and hardship. The grounds for the tenant include sale of the residential premises (not revealed when this agreement was entered into), breach of this agreement by the landlord and hardship. For more information refer to that Act or contact NSW Fair Trading on 13 32 20.

6. Warning

It is an offence for any person to obtain possession of the residential premises without an order of the Civil and Administrative Tribunal if the tenant does not willingly move out. A court can order fines and compensation to be paid for such an offence.

RESIDENTIAL TENANCY AGREEMENT

THE LANDLORD AND TENANT ENTER INTO THIS AGREEMENT AND AGREE TO ALL ITS TERMS.

All signatories to this agreement consent to it being entered into and signed online.

SIGNED BY THE LANDLORD

in the presence of: Auson Melvey
(Name of witness)

Alley
(Signature of witness)

SIGNED BY OURIMBAH REAL ESTATE PTY LTD
ON BEHALF OF LANDLORD

R Allwood
(Signature of landlord)

SIGNED BY THE TENANT

in the presence of: Emily Blake
(Name of witness)

EB
(Signature of witness)

Erin Koranyi
(Signature of tenant)

in the presence of: Roslyn Allwood
(Name of witness)

R Allwood
(Signature of witness)

Erin
(Signature of tenant)

in the presence of: _____
(Name of witness)

(Signature of witness)

(Signature of tenant)

in the presence of: _____
(Name of witness)

(Signature of witness)

(Signature of tenant)

The tenant acknowledges that, at or before the time of signing this residential tenancy agreement, the tenant was given a copy of an information statement published by NSW Fair Trading.

Erin Koranyi
(Signature of tenant)

(Signature of tenant)

Erin
(Signature of tenant)

(Signature of tenant)

For information about your rights and obligations as a landlord or tenant, contact:

- (a) NSW Fair Trading on 13 32 20 or www.fairtrading.nsw.gov.au, or
- (b) Law Access NSW on 1300 888 529 or www.lawaccess.nsw.gov.au, or
- (c) your local Tenants Advice and Advocacy Service at www.tenants.org.au

New tenant checklist

What you must know before you sign a lease

At the start of every tenancy, your landlord or agent should give you:

- a copy of this information (*the New tenant checklist*)
- a copy of your lease (tenancy agreement)
- 2 copies of the premises condition report (more on that later)
- an invitation to lodge the bond using Rental Bonds Online (RBO). Or, if you are unable to use RBO, a bond lodgement form for you to sign, so that it can be lodged with NSW Fair Trading
- keys to your new home.

If applicable, you should also receive:

- a certificate of compliance for a swimming pool (more on that later)
- a copy of the by-laws, if the property is in a strata complex
- notification if the premises has been listed on the Loose-Fill Asbestos Insulation Register (more on that later)
- notification of any other material fact relating to the premises (more on that later).

Before you sign the lease, make sure you read it thoroughly. If there is anything in the lease that you do not understand, ask questions.

Remember, you are committing to a legally binding contract with no cooling-off period. You want to be certain you understand and agree to what you are signing.

You should only sign the lease when you can answer Yes to the following statements.

The lease

- I have read the lease and asked questions if there were things I did not understand.
- I know the length of the lease is negotiated before I sign, which means it can be for 6 months, 12 months, or some other period.

- I know that I must be offered at least **one** way to pay the rent that does not involve paying a fee to a third party.
- I know that any additional terms to the lease must be negotiated before I sign.
- I have checked that all additional terms to the lease are legal. For example, the lease does **not** include a term requiring me to have the carpet professionally cleaned when I leave, unless I have agreed to that as part of a condition to allow me to keep a pet on the premises.

Promised repairs

For any promises made by the landlord or agent (for example, replace the oven, paint a room, clean up the backyard, etc.):

- I have made sure these have already been done

or

- I have an undertaking in writing (before signing the lease) that they will be done.

Upfront costs

I am **not** being required to pay:

- more than 2 weeks rent in advance, unless I freely offer to pay more
- more than 4 weeks rent as a rental bond.

I am **not** being charged for:

- the cost of preparing my lease
- the initial supply of keys and security devices to each tenant named on the lease.

Govin Koravala

Kelvin



Fair
Trading



REINSW

for members
since 1910

Managing your bond online

Your landlord or agent **must** give you the option to use Rental Bonds Online (RBO) to pay your bond. You can use RBO to securely pay your bond direct to NSW Fair Trading using a credit card or BPAY, without the need to fill out and sign a bond lodgement form. Once registered, you can continue to use your RBO account for future tenancies.

If you decide not to use RBO, you can ask your agent or landlord for a paper bond lodgement form for you to sign, so that it can be lodged with NSW Fair Trading.

Swimming and spa pools

Does the property have a swimming or spa pool? If so, the landlord or agent must give you a copy of a valid certificate of compliance or occupation certificate issued in the past 3 years. This does not apply if you are renting in a strata or community scheme of more than 2 lots.

Property containing loose-fill asbestos insulation

Properties in NSW that test positive for loose-fill asbestos insulation will have the property address included in a public register (available on the NSW Fair Trading website). If a property has been listed on this public register, the agent or private landlord must disclose this information to new tenants. The following section lists the other information that must be provided to tenants before they sign a lease.

What tenants must be told

Sometimes a residential property has something in its history that you should know. If the landlord or agent is aware of any of the following facts, they must inform you:

- if the property:
 - has been affected by flooding or bushfire in the previous 5 years
 - has significant health or safety risks (unless they are obvious when you inspect the property)
 - has been the scene of a violent crime in the previous 5 years

- is affected by zoning or laws that will not allow you to obtain a parking permit and only paid parking is available in the area
- is provided with council waste services on a different basis to other premises in the area
- is listed on the loose-fill asbestos insulation register
- if other people are entitled to share the driveway or walkway.

After you move in

- Fill in your part of the condition report and make sure you return a copy to the landlord or agent within 7 days. This is an important piece of evidence. If you do not take the time to complete it accurately, money could be taken out of your bond to pay for damage that was already there when you moved in.
- If you lodged the bond using RBO, make sure you receive an email or SMS notification from Fair Trading confirming your bond has been received. If the bond was not lodged using RBO, make sure you get a letter from Fair Trading sometime during the first 2 months saying that your bond has been received and advising you of your Rental Bond Number.

If you do not receive an email, SMS notification or letter, call NSW Fair Trading to make sure the bond has been lodged.

Top tips for problem-free renting

Follow these useful tips to help avoid problems while you are renting:

- Photos are a great way to record the condition of the property when you first move in. Take date-stamped photos of the property, especially areas that are damaged or unclean. Keep these photos in case the landlord objects to returning your bond at the end of your tenancy.
- Keep a copy of your lease, condition report, rent receipts, Rental Bond Number and copies of letters/emails you send or receive in a safe place where you can easily find it later.

- Never stop paying your rent, even if the landlord is not complying with their side of the agreement (e.g. by failing to do repairs). You could end up being evicted if you do.
- Comply with the terms of your lease. In particular, never make any alterations, keep a pet or let other people move in without asking the landlord or agent for permission first.
- Keep a diary of your dealings with the landlord or agent - record all the times and dates of conversations, who you spoke to and what they agreed to do. If repairs are needed, put your request in writing to the landlord or agent and keep a copy. This type of evidence is very helpful if a dispute arises that ends up in the NSW Civil and Administrative Tribunal (NCAT).
- Consider taking out home contents insurance. It will cover your belongings in case of theft, fires and natural disasters. The landlord's building insurance, if they have it, will not cover your things.
- If the property has a pool or garden, be clear about what the landlord or agent expects you to do to maintain them.
- Be careful with what you sign relating to your tenancy and do not let anybody rush you. Never sign a blank form, such as a 'Claim for refund of bond' form.
- If you are happy in the place and your lease ends, consider asking for the lease to be renewed for another fixed term. This will remove the worry about being unexpectedly asked to leave and can help to lock in the rent for the next period of time.

www.tenants.org.au for details of your nearest service or check your local phone directory.

Landlords and agents must give a copy of this information statement to all new tenants before they sign a residential lease. Fines can be imposed if this is not done.

Further information

Go to the Fair Trading website or call 13 32 20 for more information about your renting rights and responsibilities.

The NSW Government funds a range of community based Tenants Advice and Advocacy Services across NSW to provide advice, information and advocacy to tenants. Go to the Tenants Union website at

Exxon Bowen

www.fairtrading.nsw.gov.au
Fair Trading enquiries 13 32 20
TTY 1300 723 404
Language assistance 13 14 50

This fact sheet must not be relied on as legal advice. For more information about this topic, refer to the appropriate legislation.

© State of New South Wales through NSW Fair Trading
You may freely copy, distribute, display or download this information with some important restrictions. See NSW Fair Trading's copyright policy at www.fairtrading.nsw.gov.au or email publications@finance.nsw.gov.au



Email Service of Notices and Documents Consent Form

Notes:

1. Use this form where service by email applies to notices or documents and where consent is required for confirmation of email service of such notices and documents.
2. If the Tenant /s or Principal /s (as applicable) has not signed this consent form, the Agent should not infer consent to email service merely from the receipt or response to emails from the Tenant /s or Principal /s (as applicable).
3. Once the Tenant /s or Principal /s (as applicable) withdraws their consent to email service of notices and documents, by providing written notice to the Agent, no further notices or other documents are to be served by email.

Date 07/11/2019I/We, Eseroma Waqa KOROVOU and Kelerayani Vatira CEREILAGI

consent to all notices and documents relevant to the proposed sale, purchase, management or letting (as applicable) of

3/7 KING STREETOURIMBAHState NSWPostcode 2258

("Property")

being served electronically via email to

~~eseroma.korovou@yahoo.com.au~~

and

Kcerealagi@yahoo.com

Where the Property is subject to a tenancy agreement or agency agreement, I/we consent to the service of notices and documents required to be given or served in respect of or under the agreement for the Property including but not limited to a termination notice, notice of intention to sell, notice of access/inspection/entry and a notice of rent increase.

I/We, Eseroma Waqa KOROVOU and Kelerayani Vatira CEREILAGI

acknowledge that by providing an email address and signing this form, I/we consent to

Ourimbah Real Estate Pty Ltd

updating my /our details of the method of communication (including my /our email address(es)) on all relevant documents for the purpose of email service of notices and other documents.

Unless I/we advise the Agent in writing that the email address(es) changes, the Agent can assume the email address(es) in this consent form remains unchanged.

I/we acknowledge that I/we may withdraw my /our consent to email service of notices and documents by giving written notice to the Agent.

Signatures of the consenting party /s:

Date: _____

Date: _____

Please return this signed form to the Agent:

Agent: Ourimbah Real Estate Pty LtdTrading as: Ourimbah Real Estate Pty LtdAddress: 33 Pacific HighwayOurimbah, NSWPostcode 2258Phone: 02 4362 1630Fax: 02 4362 2379Mobile: enquiries@morissetcityrealestate.com.auEmail: enquiries@ourimbahrealestate.com.au

RESIDENTIAL TENANCY AGREEMENT

Term of agreement

The term of this agreement is:

- 6 months
 12 months
 2 years
 3 years
 5 years
 Other (please specify):
 Periodic (no end date)

starting on and ending on [*Cross out if not applicable*]

Note. For a residential tenancy agreement having a fixed term of more than 3 years, the agreement must be annexed to the form approved by the Registrar-General for registration under the *Real Property Act 1900*.

Residential Premises

The residential premises are [*Insert address*]

Address

Suburb

State

Postcode

The residential premises include: [*Include any inclusions, for example, a parking space or furniture provided. Attach additional pages if necessary.*]

The residential premises **do not include**: [*List anything such as a parking space, garage or storeroom which do not form part of the residential premises*]

Rent

The rent is per payable in advance starting on .

Note. Under section 33 of the *Residential Tenancies Act 2010*, a landlord, or landlord's agent, must not require a tenant to pay more than 2 weeks rent in advance under this Agreement.

The method by which the rent must be paid:

(a) to at by cash or Electronic Funds Transfer (EFT), or

(b) into the following account, or any other account nominated by the landlord:

BSB number: Account number:

Account name:

Payment reference: , or

(c) as follows:

Note. The landlord or landlord's agent must permit the tenant to pay the rent by at least one means for which the tenant does not incur a cost (other than bank fees or other account fees usually payable for the tenant's transactions) (see clause 4.1) and that is reasonably available to the tenant.

Rental bond [*cross out if there is not going to be a bond*]

A rental bond of must be paid by the tenant on signing this agreement.

The amount of the rental bond must not be more than 4 weeks rent.

The tenant provided the rental bond amount to:

- the landlord or another person, or
 the landlord's agent, or
 NSW Fair Trading through Rental Bonds Online.

Note. All rental bonds must be lodged with NSW Fair Trading. If the bond is paid to the landlord or another person, it must be deposited within 10 working days after it is paid using the Fair Trading approved form. If the bond is paid to the landlord's agent, it must be deposited within 10 working days after the end of the month in which it is paid.

RESIDENTIAL TENANCY AGREEMENT
 RESIDENTIAL TENANCIES REGULATION 2019
RENEWAL**IMPORTANT INFORMATION**Please read this before completing the residential tenancy agreement (the **Agreement**).

1. This form is your written record of your tenancy agreement. This is a binding contract under the *Residential Tenancies Act 2010*, so please read all terms and conditions carefully.
2. If you need advice or information on your rights and responsibilities, please call NSW Fair Trading on 13 32 20 or visit www.fairtrading.nsw.gov.au before signing the Agreement.
3. If you require extra space to list additional items and terms, attach a separate sheet. All attachments should be signed and dated by both the landlord or the landlord's agent and the tenant to show that both parties have read and agree to the attachments.
4. The landlord or the landlord's agent must give the tenant a copy of the signed Agreement and any attachments, two copies or one electronic copy of the completed condition report and a copy of NSW Fair Trading's Tenant Information Statement publication.

 This agreement is made on 11 / 01 / 2021 at 33 PACIFIC HWY OURIMBAH NSW NSW Between

 Landlord *[Insert name and telephone number or other contact details of landlord(s). If the landlord does not ordinarily reside in New South Wales, specify the State, Territory or, if not in Australia, country in which the landlord ordinarily resides]*

 Landlord 1 Name: Andrew BLYTHIN A.B.N. (if applicable):
 Landlord telephone number or other contact details: dennis@blythin.com.au
 If not in NSW, the State, Territory or country (if not Australia) the landlord ordinarily resides in:

 Landlord 2 Name: A.B.N. (if applicable):
 Landlord telephone number or other contact details:
 If not in NSW, the State, Territory or country (if not Australia) the landlord ordinarily resides in:
Note. These details must be provided for landlord(s), whether or not there is a landlord's agent.*[Insert business address or residential address of landlord(s)]***Note.** These details must be provided for landlord(s) if there is no landlord's agent.*[Insert corporation name and business address of landlord(s) if landlord(s) is a corporation]***Tenant** *[Insert name of tenant(s) and contact details]*
 Tenant 1 Name Eseroma Waqa KOROVOU
 Phone 0404 979 019 Email eseroma.korovou@yahoo.com.au

 Tenant 2 Name Kelerayani Vatira CEREILAGI
 Phone Email kcereilagi@yahoo.com

 Tenant 3 Name
 Phone Email

 Tenant 4 Name
 Phone Email
Landlord's agent details *[Insert name of landlord's agent (if any) and contact details]*
 Licensee Ourimbah Real Estate Pty Ltd
 Trading as OURIMBAH REAL ESTATE PTY LTD A.B.N. 65003484277
 Address 33 PACIFIC HWY
 OURIMBAH NSW NSW Postcode 2258
 Phone 02 4362 1630 Fax 02 4362 2379 Mobile Email enquiries@ourimbahrealestate.com.au
Tenant's agent details *[Insert name of tenant's agent (if any) and contact details]*
 Name / s A.B.N.
 Address
 Postcode
 Phone Fax Mobile Email

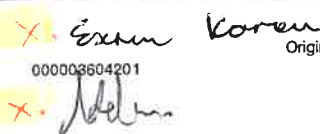

RESIDENTIAL TENANCY AGREEMENT

IMPORTANT INFORMATION

Maximum number of occupants

No more than persons may ordinarily live in the premises at any one time.

Urgent repairs

Nominated tradespeople for urgent repairs:

Electrical repairs: Telephone:

Plumbing repairs: Telephone:

Other repairs: Telephone:

Water usage

Will the tenant be required to pay separately for water usage? Yes No If yes, see clauses 12 and 13.

Utilities

Is electricity supplied to the premises from an embedded network? Yes No

Is gas supplied to the premises from an embedded network? Yes No

For more information on consumer rights if electricity or gas is supplied from an embedded network contact NSW Fair Trading.

Smoke alarms

Indicate whether the smoke alarms installed in the residential premises are hardwired or battery operated:

Hardwired smoke alarm

Battery operated smoke alarm

If the smoke alarms are battery operated, are the batteries in the smoke alarms of a kind the tenant can replace? Yes No

If yes, specify the type of battery that needs to be used if the battery in the smoke alarm needs to be replaced:

If the smoke alarms are hardwired, are the back-up batteries in the smoke alarms of a kind the tenant can replace? Yes No

If yes, specify the type of back-up battery that needs to be used if the back-up battery in the smoke alarm needs to be replaced:

If the *Strata Schemes Management Act 2015* applies to the residential premises, is the owners corporation of the strata scheme responsible for the repair and replacement of smoke alarms in the residential premises? Yes No

Strata by-laws

Are there any strata or community scheme by-laws applicable to the residential premises? Yes No If yes, see clauses 38 and 39.

Giving notices and other documents electronically [optional] [Cross out if not applicable]

Indicate below for each person whether the person provides express consent to any notice and any other document under section 223 of the *Residential Tenancies Act 2010* being given or served on them by email. The *Electronic Transactions Act 2000* applies to notices and other documents you send or receive electronically.

[You should only consent to electronic service if you check your emails regularly. If there is more than one tenant on the agreement, all tenants should agree on a single email address for electronic service. This will help ensure co-tenants receive notices and other documents at the same time.]

Landlord

Does the landlord give express consent to the electronic service of notices and documents? Yes No If yes, see clause 50.

[Specify email address to be used for the purpose of serving notices and documents.]

Tenant

Does the tenant give express consent to the electronic service of notices and documents? Yes No If yes, see clause 50.

[Specify email address to be used for the purpose of serving notices and documents.]

Condition report

A condition report relating to the condition of the premises must be completed by or on behalf of the landlord before or when this agreement is given to the tenant for signing.

Tenancy laws

The *Residential Tenancies Act 2010* and the *Residential Tenancies Regulation 2019* apply to this agreement. Both the landlord and the tenant must comply with these laws.

RESIDENTIAL TENANCY AGREEMENT

RIGHT TO OCCUPY THE PREMISES

1. **The landlord agrees** that the tenant has the right to occupy the residential premises during the tenancy. The residential premises include the additional things (if any) noted under "**Residential premises**".

COPY OF AGREEMENT

2. **The landlord agrees** to give the tenant:
 - 2.1 a copy of this agreement before or when the tenant gives the signed copy of the agreement to the landlord or landlord's agent, and
 - 2.2 a copy of this agreement signed by both the landlord and the tenant as soon as is reasonably practicable.

RENT

3. **The tenant agrees:**
 - 3.1 to pay rent on time, and
 - 3.2 to reimburse the landlord for the cost of replacing rent deposit books or rent cards lost by the tenant, and
 - 3.3 to reimburse the landlord for the amount of any fees paid by the landlord to a bank or other authorised deposit-taking institution as a result of funds of the tenant not being available for rent payment on the due date.
4. **The landlord agrees:**
 - 4.1 to provide the tenant with at least one means to pay rent for which the tenant does not incur a cost (other than bank fees or other account fees usually payable for the tenant's transactions) and that is reasonably available to the tenant, and
 - 4.2 not to require the tenant to pay more than 2 weeks rent in advance or to pay rent for a period of the tenancy before the end of the previous period for which rent has been paid, and
 - 4.3 not to require the tenant to pay rent by a cheque or other negotiable instrument that is post-dated, and
 - 4.4 to accept payment of unpaid rent after the landlord has given a termination notice on the ground of failure to pay rent if the tenant has not vacated the residential premises, and
 - 4.5 not to use rent paid by the tenant for the purpose of any amount payable by the tenant other than rent, and
 - 4.6 to give a rent receipt to the tenant if rent is paid in person (other than by cheque), and
 - 4.7 to make a rent receipt available for collection by the tenant or to post it to the residential premises or to send it by email to an email address specified in this agreement by the tenant for the service of documents of that kind if rent is paid by cheque, and
 - 4.8 to keep a record of rent paid under this agreement and to provide a written statement showing the rent record for a specified period within 7 days of a request by the tenant (unless the landlord has previously provided a statement for the same period).

Note. The landlord and the tenant may, by agreement, change the manner in which rent is payable under this agreement.

RENT INCREASES

5. **The landlord and the tenant agree** that the rent cannot be increased after the end of the fixed term (if any) of this agreement or under this agreement if the agreement is for a fixed term of 2 years or more, unless the landlord gives not less than 60 days written notice of the increase to the tenant. The notice must specify the increased rent and the day from which it is payable.

Note. Section 42 of the *Residential Tenancies Act 2010* sets out the circumstances in which rent may be increased during the fixed term of a residential tenancy agreement. An additional term for this purpose may be included in the agreement.

6. **The landlord and the tenant agree** that the rent may not be increased after the end of the fixed term (if any) of this agreement more than once in any 12-month period.
7. **The landlord and the tenant agree:**
 - 7.1 that the increased rent is payable from the day specified in the notice, and
 - 7.2 that the landlord may cancel or reduce the rent increase by a later notice that takes effect on the same day as the original notice, and
 - 7.3 that increased rent under this agreement is not payable unless the rent is increased in accordance with this agreement and the *Residential Tenancies Act 2010* or by the Civil and Administrative Tribunal.

RENT REDUCTIONS

8. **The landlord and the tenant agree** that the rent abates if the residential premises:
 - 8.1 are destroyed, or become wholly or partly uninhabitable, otherwise than as a result of a breach of this agreement, or
 - 8.2 cease to be lawfully usable as a residence, or
 - 8.3 are compulsorily appropriated or acquired by an authority.
9. The landlord and the tenant may, at any time during this agreement, agree to reduce the rent payable.

PAYMENT OF COUNCIL RATES, LAND TAX, WATER AND OTHER CHARGES

10. **The landlord agrees** to pay:
 - 10.1 rates, taxes or charges payable under any Act (other than charges payable by the tenant under this agreement), and
 - 10.2 the installation costs and charges for initial connection to the residential premises of an electricity, water, gas, bottled gas or oil supply service, and
 - 10.3 all charges for the supply of electricity, non-bottled gas or oil to the tenant at the residential premises that are not separately metered, and

Note 1. Clause 10.3 does not apply to premises located in an embedded network in certain circumstances in accordance with clauses 34 and 35 of the *Residential Tenancies Regulation 2019*.

Note 2. Clause 10.3 does not apply to social housing tenancy agreements in certain circumstances, in accordance with clause 36 of the *Residential Tenancies Regulation 2019*.

 - 10.4 the costs and charges for the supply or hire of gas bottles for the supply of bottled gas at the commencement of the tenancy, and
 - 10.5 all charges (other than water usage charges) in connection with a water supply service to separately metered residential premises, and
 - 10.6 all charges in connection with a water supply service to residential premises that are not separately metered, and
 - 10.7 all charges for the supply of sewerage services (other than for pump out septic services) or the supply or use of drainage services to the residential premises, and
 - 10.8 all service availability charges, however described, for the supply of non-bottled gas to the residential premises if the premises are separately metered but do not have any appliances, supplied by the landlord, for which gas is required and the tenant does not use gas supplied to the premises, and

RESIDENTIAL TENANCY AGREEMENT

- 10.9** the costs and charges for repair, maintenance or other work carried out on the residential premises which is required to facilitate the proper installation or replacement of an electricity meter, in working order, including an advanced meter, if the meter installation is required by the retailer to replace an existing meter because the meter is faulty, testing indicates the meter may become faulty or the meter has reached the end of its life.
- 11. The tenant agrees to pay:**
- 11.1** all charges for the supply of electricity or oil to the tenant at the residential premises if the premises are separately metered, and
- 11.2** all charges for the supply of non-bottled gas to the tenant at the residential premises if the premises are separately metered, unless the premises do not have any appliances supplied by the landlord for which gas is required and the tenant does not use gas supplied to the premises, and
- Note.** Charges for the supply of gas in certain circumstances may also be payable by a tenant under a social housing agreement in accordance with clause 36 of the *Residential Tenancies Regulation 2019*.
- 11.3** all charges for the supply of bottled gas to the tenant at the residential premises except for the costs and charges for the supply or hire of gas bottles at the start of the tenancy, and
- 11.4** all charges for pumping out a septic system used for the residential premises, and
- 11.5** any excess garbage charges relating to the tenant's use of the residential premises, and
- 11.6** water usage charges, if the landlord has installed water efficiency measures referred to in clause 10 of the *Residential Tenancies Regulation 2019* and the residential premises:
- 11.6.1** are separately metered, or
- 11.6.2** are not connected to a water supply service and water is delivered by vehicle.
- Note.** Separately metered is defined in the *Residential Tenancies Act 2010*.
- 12. The landlord agrees** that the tenant is not required to pay water usage charges unless:
- 12.1** the landlord gives the tenant a copy of the part of the water supply authority's bill setting out the charges, or other evidence of the cost of water used by the tenant, and
- 12.2** the landlord gives the tenant at least 21 days to pay the charges, and
- 12.3** the landlord requests payment of the charges by the tenant not later than 3 months after the issue of the bill for the charges by the water supply authority, and
- 12.4** the residential premises have the following water efficiency measures:
- 12.4.1** all internal cold water taps and single mixer taps for kitchen sinks or bathroom hand basins on the premises have a maximum flow rate of 9 litres a minute,
- 12.4.2** on and from 23 March 2025, all toilets are dual flush toilets that have a minimum 3 star rating in accordance with the WELS scheme,
- 12.4.3** all showerheads have a maximum flow rate of 9 litres a minute,
- 12.4.4** at the commencement of the residential tenancy agreement and whenever any other water efficiency measures are installed, repaired or upgraded, the premises are checked and any leaking taps or toilets on the premises have been fixed.
- 13. The landlord agrees** to give the tenant the benefit of, or an amount equivalent to, any rebate received by the landlord for water usage charges payable or paid by the tenant.
- POSSESSION OF THE PREMISES**
- 14. The landlord agrees:**
- 14.1** to make sure the residential premises are vacant so the tenant can move in on the date agreed, and
- 14.2** to take all reasonable steps to ensure that, at the time of signing this agreement, there is no legal reason why the premises cannot be used as a residence for the term of this agreement.
- TENANT'S RIGHT TO QUIET ENJOYMENT**
- 15. The landlord agrees:**
- 15.1** that the tenant will have quiet enjoyment of the residential premises without interruption by the landlord or any person claiming by, through or under the landlord or having superior title to that of the landlord (such as a head landlord), and
- 15.2** that the landlord or the landlord's agent will not interfere with, or cause or permit any interference with, the reasonable peace, comfort or privacy of the tenant in using the residential premises, and
- 15.3** that the landlord or the landlord's agent will take all reasonable steps to ensure that the landlord's other neighbouring tenants do not interfere with the reasonable peace, comfort or privacy of the tenant in using the residential premises.
- USE OF THE PREMISES BY TENANT**
- 16. The tenant agrees:**
- 16.1** not to use the residential premises, or cause or permit the premises to be used, for any illegal purpose, and
- 16.2** not to cause or permit a nuisance, and
- 16.3** not to interfere, or cause or permit interference, with the reasonable peace, comfort or privacy of neighbours, and
- 16.4** not to intentionally or negligently cause or permit any damage to the residential premises, and
- 16.5** not to cause or permit more people to reside in the residential premises than is permitted by this agreement.
- 17. The tenant agrees:**
- 17.1** to keep the residential premises reasonably clean, and
- 17.2** to notify the landlord as soon as practicable of any damage to the residential premises, and
- 17.3** that the tenant is responsible to the landlord for any act or omission by a person who is lawfully on the residential premises if the person is only permitted on the premises with the tenant's consent and the act or omission would be in breach of this agreement if done or omitted by the tenant, and
- 17.4** that it is the tenant's responsibility to replace light globes on the residential premises.
- 18. The tenant agrees, when this agreement ends and before giving vacant possession of the premises to the landlord:**
- 18.1** to remove all the tenant's goods from the residential premises, and
- 18.2** to leave the residential premises as nearly as possible in the same condition, fair wear and tear excepted, as at the commencement of the tenancy, and
- 18.3** to leave the residential premises reasonably clean, having regard to their condition at the commencement of the tenancy, and
- 18.4** to remove or arrange for the removal of all rubbish from the residential premises in a way that is lawful and in accordance with council requirements, and

RESIDENTIAL TENANCY AGREEMENT

- 18.5** to make sure that all light fittings on the premises have working globes, and
- 18.6** to return to the landlord all keys, and other opening devices or similar devices, provided by the landlord.

Note. Under section 54 of the *Residential Tenancies Act 2010*, the vicarious liability of a tenant for damage to residential premises caused by another person is not imposed on a tenant who is the victim of a domestic violence offence, or a co-tenant who is not a relevant domestic violence offender, if the damage occurred during the commission of a domestic violence offence (within the meaning of that Act).

LANDLORD'S GENERAL OBLIGATIONS FOR RESIDENTIAL PREMISES

19. The landlord agrees:

- 19.1** to make sure that the residential premises are reasonably clean and fit to live in, and
- Note 1.** Section 52 of the *Residential Tenancies Act 2010* specifies the minimum requirements that must be met for residential premises to be fit to live in. These include that the residential premises:
- are structurally sound, and
 - have adequate natural light or artificial lighting in each room of the premises other than a room that is intended to be used only for the purposes of storage or a garage, and
 - have adequate ventilation, and
 - are supplied with electricity or gas and have an adequate number of electricity outlet sockets or gas outlet sockets for the supply of lighting and heating to, and use of appliances in, the premises, and
 - have adequate plumbing and drainage, and
 - are connected to a water supply service or infrastructure that supplies water (including, but not limited to, a water bore or water tank) that is able to supply to the premises hot and cold water for drinking and ablution and cleaning activities, and
 - contain bathroom facilities, including toilet and washing facilities, that allow privacy for the user.

Note 2. Premises are structurally sound only if the floors, ceilings, walls, supporting structures (including foundations), doors, windows, roof, stairs, balconies, balustrades and railings:

- are in a reasonable state of repair, and
 - with respect to the floors, ceilings, walls and supporting structures—are not subject to significant dampness, and
 - with respect to the roof, ceilings and windows—do not allow water penetration into the premises, and
 - are not liable to collapse because they are rotted or otherwise defective.
- 19.2** to make sure that all light fittings on the residential premises have working light globes on the commencement of the tenancy, and
- 19.3** to keep the residential premises in a reasonable state of repair, considering the age of, the rent paid for and the prospective life of the premises, and
- 19.4** not to interfere with the supply of gas, electricity, water, telecommunications or other services to the residential premises (unless the interference is necessary to avoid danger to any person or enable maintenance or repairs to be carried out), and

- 19.5** not to hinder a tradesperson's entry to the residential premises when the tradesperson is carrying out maintenance or repairs necessary to avoid health or safety risks to any person, or to avoid a risk that the supply of gas, electricity, water, telecommunications or other services to the residential premises may be disconnected, and
- 19.6** to comply with all statutory obligations relating to the health or safety of the residential premises, and
- 19.7** that a tenant who is the victim of a domestic violence offence or a co-tenant who is under the same agreement as the victim of the domestic violence offence but is not a relevant domestic violence offender is not responsible to the landlord for any act or omission by a co-tenant that is a breach of this agreement if the act or omission constitutes or resulted in damage to the premises and occurred during the commission of a domestic violence offence.

URGENT REPAIRS

20. The landlord agrees to pay the tenant, within 14 days after receiving written notice from the tenant, any reasonable costs (not exceeding \$1,000) that the tenant has incurred for making urgent repairs to the residential premises (of the type set out below) so long as:

- the damage was not caused as a result of a breach of this agreement by the tenant, and
- the tenant gives or makes a reasonable attempt to give the landlord notice of the damage, and
- the tenant gives the landlord a reasonable opportunity to make the repairs, and
- the tenant makes a reasonable attempt to have any appropriate tradesperson named in this agreement make the repairs, and
- the repairs are carried out, where appropriate, by licensed or properly qualified persons, and
- the tenant, as soon as possible, gives or tries to give the landlord written details of the repairs, including the cost and the receipts for anything the tenant pays for.

Note. The type of repairs that are **urgent repairs** are defined in the *Residential Tenancies Act 2010* and are defined as follows:

- a burst water service,
- an appliance, fitting or fixture that uses water or is used to supply water that is broken or not functioning properly, so that a substantial amount of water is being wasted,
- a blocked or broken lavatory system,
- a serious roof leak,
- a gas leak,
- a dangerous electrical fault,
- flooding or serious flood damage,
- serious storm or fire damage,
- a failure or breakdown of the gas, electricity or water supply to the premises,
- a failure or breakdown of any essential service on the residential premises for hot water, cooking, heating, cooling or laundering,
- any fault or damage that causes the premises to be unsafe or insecure.

SALE OF THE PREMISES

21. The landlord agrees:

- 21.1** to give the tenant written notice that the landlord intends to sell the residential premises, at least 14 days before the premises are made available for inspection by potential purchasers, and

RESIDENTIAL TENANCY AGREEMENT

21.2 to make all reasonable efforts to agree with the tenant as to the days and times when the residential premises are to be available for inspection by potential purchasers.

22. **The tenant agrees** not to unreasonably refuse to agree to days and times when the residential premises are to be available for inspection by potential purchasers.

23. **The landlord and the tenant agree:**

23.1 that the tenant is not required to agree to the residential premises being available for inspection more than twice in a period of a week, and

23.2 that, if they fail to agree, the landlord may show the residential premises to potential purchasers not more than twice in any period of a week and must give the tenant at least 48 hours notice each time.

LANDLORD'S ACCESS TO THE PREMISES

24. **The landlord agrees** that the landlord, the landlord's agent or any person authorised in writing by the landlord, during the currency of this agreement, may only enter the residential premises in the following circumstances:

24.1 in an emergency (including entry for the purpose of carrying out urgent repairs),

24.2 if the Civil and Administrative Tribunal so orders,

24.3 if there is good reason for the landlord to believe the premises are abandoned,

24.4 if there is good reason for serious concern about the health of the tenant or any other person on the residential premises and a reasonable attempt has been made to obtain consent to the entry,

24.5 to inspect the premises, if the tenant is given at least 7 days written notice (no more than 4 inspections are allowed in any period of 12 months),

24.6 to carry out, or assess the need for, necessary repairs, if the tenant is given at least 2 days notice each time,

24.7 to carry out, or assess the need for, work relating to statutory health and safety obligations relating to the residential premises, if the tenant is given at least 2 days notice each time,

24.8 to show the premises to prospective tenants on a reasonable number of occasions if the tenant is given reasonable notice on each occasion (this is only allowed during the last 14 days of the agreement),

24.9 to value the property, if the tenant is given 7 days notice (not more than one valuation is allowed in any period of 12 months),

24.10 to take photographs, or make visual recordings, of the inside of the premises in order to advertise the premises for sale or lease, if the tenant is given reasonable notice and reasonable opportunity to move any of their possessions that can reasonably be moved out of the frame of the photograph or the scope of the recording (this is only allowed once in a 28 day period before marketing of the premises starts for sale or lease or the termination of this agreement),

24.11 if the tenant agrees.

25. **The landlord agrees** that a person who enters the residential premises under clause 24.5, 24.6, 24.7, 24.8, 24.9 or 24.10 of this agreement:

25.1 must not enter the premises on a Sunday or a public holiday, unless the tenant agrees, and

25.2 may enter the premises only between the hours of 8.00 a.m. and 8.00 p.m., unless the tenant agrees to another time, and

25.3 must not stay on the residential premises longer than is necessary to achieve the purpose of the entry to the premises, and

25.4 must, if practicable, notify the tenant of the proposed day and time of entry.

26. **The landlord agrees** that, except in an emergency (including to carry out urgent repairs), a person other than the landlord or the landlord's agent must produce to the tenant the landlord's or the landlord's agent's written permission to enter the residential premises.

27. **The tenant agrees** to give access to the residential premises to the landlord, the landlord's agent or any person, if they are exercising a right to enter the residential premises in accordance with this agreement.

PUBLISHING PHOTOGRAPHS OR VISUAL RECORDINGS

28. **The landlord agrees** that the landlord or the landlord's agent must not publish any photographs taken or visual recordings made of the inside of the residential premises in which the tenant's possessions are visible unless they first obtain written consent from the tenant.

Note. See section 55A of the *Residential Tenancies Act 2010* for when a photograph or visual recording is published.

29. **The tenant agrees** not to unreasonably withhold consent. If the tenant is in circumstances of domestic violence within the meaning of section 105B of the *Residential Tenancies Act 2010*, it is not unreasonable for the tenant to withhold consent.

FIXTURES, ALTERATIONS, ADDITIONS OR RENOVATIONS TO THE PREMISES

30. **The tenant agrees:**

30.1 not to install any fixture or renovate, alter or add to the residential premises without the landlord's written permission, and

30.2 that certain kinds of fixtures or alterations, additions or renovations that are of a minor nature specified by clause 22(2) of the *Residential Tenancies Regulation 2019* may only be carried out by a person appropriately qualified to carry out those alterations unless the landlord gives consent, and

30.3 to pay the cost of a fixture, installed by or on behalf of the tenant, or any renovation, alteration or addition to the residential premises, unless the landlord otherwise agrees, and

30.4 not to remove, without the landlord's permission, any fixture attached by the tenant that was paid for by the landlord or for which the landlord gave the tenant a benefit equivalent to the cost of the fixture, and

30.5 to notify the landlord of any damage caused by removing any fixture attached by the tenant, and

30.6 to repair any damage caused by removing the fixture or compensate the landlord for the reasonable cost of repair.

31. **The landlord agrees** not to unreasonably withhold consent to a fixture, or to an alteration, addition or renovation that is of a minor nature.

Note. The *Residential Tenancies Regulation 2019* provides a list of the kinds of fixtures or alterations, additions or renovations of a minor nature to which it would be unreasonable for a landlord to withhold consent and which of those fixtures, or alterations, additions or renovations the landlord may give consent to on the condition that the fixture or alteration, addition or renovation is carried out by an appropriately qualified person.

LOCKS AND SECURITY DEVICES

32. **The landlord agrees:**

32.1 to provide and maintain locks or other security devices necessary to keep the residential premises reasonably secure, and

RESIDENTIAL TENANCY AGREEMENT

- 32.2** to give each tenant under this agreement a copy of the key or opening device or information to open any lock or security device for the residential premises or common property to which the tenant is entitled to have access, and
- 32.3** not to charge the tenant for the cost of providing the copies except to recover the cost of replacement or additional copies, and
- 32.4** not to alter, remove or add any lock or other security device without reasonable excuse (which includes an emergency, an order of the Civil and Administrative Tribunal, termination of a co-tenancy or an apprehended violence order prohibiting a tenant or occupant from having access) or unless the tenant agrees, and
- 32.5** to give each tenant under this agreement a copy of any key or other opening device or information to open any lock or security device that the landlord changes as soon as practicable (and no later than 7 days) after the change.

33. The tenant agrees:

- 33.1** not to alter, remove or add any lock or other security device without reasonable excuse (which includes an emergency, an order of the Civil and Administrative Tribunal, termination of a co-tenancy or an apprehended violence order prohibiting a tenant or occupant from having access) or unless the landlord agrees, and
- 33.2** to give the landlord a copy of the key or opening device or information to open any lock or security device that the tenant changes within 7 days of the change.
- 34.** A copy of a changed key or other opening device need not be given to the other party if the other party agrees not to be given a copy or the Civil and Administrative Tribunal authorises a copy not to be given or the other party is prohibited from access to the residential premises by an apprehended violence order.

TRANSFER OF TENANCY OR SUB-LETTING BY TENANT

35. The landlord and the tenant agree that:

- 35.1** the tenant may, with the landlord's written permission, transfer the tenant's tenancy under this agreement or sub-let the residential premises, and
- 35.2** the landlord may refuse permission (whether or not it is reasonable to do so) to the transfer of the whole of the tenancy or sub-letting the whole of the residential premises, and
- 35.3** the landlord must not unreasonably refuse permission to a transfer of part of a tenancy or a sub-letting of part of the residential premises, and
- 35.4** without limiting clause 35.3, the landlord may refuse permission to a transfer of part of the tenancy or to sub-letting part of the residential premises if the number of occupants would be more than is permitted under this agreement or any proposed tenant or sub-tenant is listed on a residential tenancy database or it would result in overcrowding of the residential premises.

Note. Clauses 35.3 and 35.4 do not apply to social housing tenancy agreements.

- 36. The landlord agrees** not to charge for giving permission other than for the landlords reasonable expenses in giving permission.

CHANGE IN DETAILS OF LANDLORD OR LANDLORD'S AGENT

37. The landlord agrees:

- 37.1** if the name and telephone number or contact details of the landlord change, to give the tenant notice in writing of the change within 14 days, and
- 37.2** if the address of the landlord changes (and the landlord does not have an agent), to give the tenant notice in writing of the change within 14 days, and

- 37.3** if the name, telephone number or business address of the landlord's agent changes or the landlord appoints an agent, to give the tenant notice in writing of the change or the agent's name, telephone number and business address, as appropriate, within 14 days, and
- 37.4** if the landlord or landlord's agent is a corporation and the name or business address of the corporation changes, to give the tenant notice in writing of the change within 14 days, and
- 37.5** if the State, Territory or country in which the landlord ordinarily resides changes, to give the tenant notice in writing of the change within 14 days.

COPY OF CERTAIN BY-LAWS TO BE PROVIDED

[Cross out if not applicable]

- 38. The landlord agrees** to give to the tenant, before the tenant enters into this agreement, a copy of the by-laws applying to the residential premises if they are premises under the *Strata Schemes Management Act 2015*.
- 39. The landlord agrees** to give to the tenant, within 7 days of entering into this agreement, a copy of the by-laws applying to the residential premises if they are premises under the *Strata Schemes Development Act 2015*, the *Community Land Development Act 1989* or the *Community Land Management Act 1989*.

MITIGATION OF LOSS

- 40. The rules of law** relating to mitigation of loss or damage on breach of a contract apply to a breach of this agreement. (For example, if the tenant breaches this agreement, the landlord will not be able to claim damages for loss which could have been avoided by reasonable effort by the landlord.)

RENTAL BOND

[Cross out this clause if no rental bond is payable]

- 41. The landlord agrees** that, where the landlord or the landlord's agent applies to the Rental Bond Board or the Civil and Administrative Tribunal for payment of the whole or part of the rental bond to the landlord, the landlord or the landlord's agent will provide the tenant with:
- 41.1** details of the amount claimed, and
- 41.2** copies of any quotations, accounts and receipts that are relevant to the claim, and
- 41.3** a copy of a completed condition report about the residential premises at the end of the residential tenancy agreement.

SMOKE ALARMS

42. The landlord agrees to:

- 42.1** ensure that smoke alarms are installed in accordance with the *Environmental Planning and Assessment Act 1979* if that Act requires them to be installed in the premises and are functioning in accordance with the regulations under that Act, and
- 42.2** conduct an annual check of all smoke alarms installed on the residential premises to ensure that the smoke alarms are functioning, and
- 42.3** install or replace, or engage a person to install or replace, all removable batteries in all smoke alarms installed on the residential premises annually, except for smoke alarms that have a removable lithium battery, and
- 42.4** install or replace, or engage a person to install or replace, a removable lithium battery in a smoke alarm in the period specified by the manufacturer of the smoke alarm, and
- 42.5** engage an authorised electrician to repair or replace a hardwired smoke alarm, and

RESIDENTIAL TENANCY AGREEMENT

- 42.6** repair or replace a smoke alarm within 2 business days of becoming aware that the smoke alarm is not working unless the tenant notifies the landlord that the tenant will carry out the repair to the smoke alarm and the tenant carries out the repair, and
- 42.7** reimburse the tenant for the costs of a repair or replacement of a smoke alarm in accordance with clause 18 of the *Residential Tenancies Regulation 2019*, that the tenant is allowed to carry out.

Note 1. Under section 64A of the *Residential Tenancies Act 2010*, repairs to a smoke alarm includes maintenance of a smoke alarm in working order by installing or replacing a battery in the smoke alarm.

Note 2. Clauses 42.2–42.7 do not apply to a landlord of premises that comprise or include a lot in a strata scheme (within the meaning of the *Strata Schemes Management Act 2015*) if the owners corporation is responsible for the repair and replacement of smoke alarms in the residential premises.

Note 3. A tenant who intends to carry out a repair to a smoke alarm may do so only in the circumstances prescribed for a tenant in clause 15 of the *Residential Tenancies Regulation 2019*.

Note 4. Section 64A of the Act provides that a smoke alarm includes a heat alarm.

43. The tenant agrees:

- 43.1** to notify the landlord if a repair or a replacement of a smoke alarm is required, including replacing a battery in the smoke alarm, and
- 43.2** that the tenant may only replace a battery in a battery-operated smoke alarm, or a back-up battery in a hardwired smoke alarm, if the smoke alarm has a removable battery or a removable back-up battery, and
- 43.3** to give the landlord written notice, as soon as practicable if the tenant will carry out and has carried out a repair or replacement, or engages a person to carry out a repair or replacement, in accordance with clauses 15–17 of the *Residential Tenancies Regulation 2019*.

Note. Clauses 43.2 and 43.3 do not apply to tenants under social housing tenancy agreements or tenants of premises that comprise or include a lot in a strata scheme (within the meaning of the *Strata Schemes Management Act 2015*) if the owners corporation is responsible for the repair and replacement of smoke alarms in the residential premises.

44. The landlord and tenant each agree not to remove or interfere with the operation of a smoke alarm installed on the residential premises unless they have a reasonable excuse to do so.

Note. The regulations made under the *Environmental Planning and Assessment Act 1979* provide that it is an offence to remove or interfere with the operation of a smoke alarm or a heat alarm in particular circumstances.

SWIMMING POOLS

[Cross out this clause if there is no swimming pool]

~~45. The landlord agrees to ensure that the requirements of the *Swimming Pools Act 1992* have been complied with in respect of the swimming pool on the residential premises.~~

*[Cross out the following clause if there is no swimming pool or the swimming pool is situated on land in a strata scheme (within the meaning of the *Strata Schemes Management Act 2015*) or in a community scheme (within the meaning of the *Community Land Development Act 1989*) and that strata or community scheme comprises more than 2 lots]*

~~46. The landlord agrees to ensure that at the time that this residential tenancy agreement is entered into:~~

- ~~46.1 the swimming pool on the residential premises is registered under the *Swimming Pools Act 1992* and has a valid certificate of compliance under that Act or a relevant occupation certificate within the meaning of that Act, and~~

~~46.2 a copy of that valid certificate of compliance or relevant occupation certificate is provided to the tenant.~~

Note. A swimming pool certificate of compliance is valid for 3 years from its date of issue.

LOOSE-FILL ASBESTOS INSULATION**47. The landlord agrees:**

- 47.1** if, at the time that this residential tenancy agreement is entered into, the premises have been and remain listed on the LFAI Register, the tenant has been advised in writing by the landlord that the premises are listed on that Register, or
- 47.2** if, during the tenancy, the premises become listed on the LFAI Register, to advise the tenant in writing, within 14 days of the premises being listed on the Register, that the premises are listed on the Register.

COMBUSTIBLE CLADDING**48. The landlord agrees** that if, during the tenancy, the landlord becomes aware of any of the following facts, the landlord will advise the tenant in writing within 14 days of becoming aware of the fact:

- 48.1** that the residential premises are part of a building in relation to which a notice of intention to issue a fire safety order, or a fire safety order, has been issued requiring rectification of the building regarding external combustible cladding,
- 48.2** that the residential premises are part of a building in relation to which a notice of intention to issue a building product rectification order, or a building product rectification order, has been issued requiring rectification of the building regarding external combustible cladding,
- 48.3** that the residential premises are part of a building where a development application or complying development certificate application has been lodged for rectification of the building regarding external combustible cladding.

SIGNIFICANT HEALTH OR SAFETY RISKS**49. The landlord agrees** that if, during the tenancy, the landlord becomes aware that the premises are subject to a significant health or safety risk, the landlord will advise the tenant in writing, within 14 days of becoming aware, that the premises are subject to the significant health or safety risk and the nature of the risk.**ELECTRONIC SERVICE OF NOTICES AND OTHER DOCUMENTS****50. The landlord and the tenant agree:**

- 50.1** to only serve any notices and any other documents, authorised or required by the *Residential Tenancies Act 2010* or the regulations or this agreement, on the other party by email if the other party has provided express consent, either as part of this agreement or otherwise, that a specified email address is to be used for the purpose of serving notices and other documents, and
- 50.2** to notify the other party in writing within 7 days if the email address specified for electronic service of notices and other documents changes, and
- 50.3** that they may withdraw their consent to the electronic service of notices and other documents at any time, by notifying the other party in writing, and
- 50.4** if a notice is given withdrawing consent to electronic service of notices and other documents, following the giving of such notice, no further notices or other documents are to be served by email.

BREAK FEE FOR FIXED TERM OF NOT MORE THAN 3 YEARS**51. The tenant agrees** that, if the tenant ends the residential tenancy agreement before the end of the fixed term of the agreement, the tenant must pay a break fee of the following amount if the fixed term is not more than 3 years:

- 51.1** 4 weeks rent if less than 25% of the fixed term has expired,

RESIDENTIAL TENANCY AGREEMENT

- 51.2** 3 weeks rent if 25% or more but less than 50% of the fixed term has expired,
51.3 2 weeks rent if 50% or more but less than 75% of the fixed term has expired,
51.4 1 week's rent if 75% or more of the fixed term has expired.

This clause does not apply if the tenant terminates a fixed term residential tenancy agreement for a fixed term of more than 3 years or if the tenant terminates a residential tenancy agreement early for a reason that is permitted under the *Residential Tenancies Act 2010*.

Note. Permitted reasons for early termination include destruction of residential premises, breach of the agreement by the landlord and an offer of social housing or a place in an aged care facility, and being in circumstances of domestic violence. Section 107 of the *Residential Tenancies Act 2010* regulates the rights of the landlord and tenant under this clause.

- 52. The landlord agrees** that the compensation payable by the tenant for ending the residential tenancy agreement before the end of the fixed term of not more than 3 years is limited to the amount specified in clause 51 and any occupation fee payable under the *Residential Tenancies Act 2010* for goods left on the residential premises.

Note. Section 107 of the *Residential Tenancies Act 2010* also regulates the rights of landlords and tenants for a residential tenancy agreement with a fixed term of more than 3 years.

ADDITIONAL TERMS

[Additional terms may be included in this agreement if:

- (a) both the landlord and the tenant agree to the terms, and
 (b) they do not conflict with the *Residential Tenancies Act 2010*, the *Residential Tenancies Regulation 2019* or any other Act, and
 (c) they do not conflict with the standard terms of this agreement.

ANY ADDITIONAL TERMS ARE NOT REQUIRED BY LAW AND ARE NEGOTIABLE]

ADDITIONAL TERM - PETS

[Cross out this clause if not applicable]

~~52. The landlord agrees that the tenant may keep the following animal on the residential premises. (Specify the breed, size etc.)~~

~~NO PETS PERMITTED~~

~~54. The tenant agrees:~~

~~54.1 to supervise and keep the animal within the premises, and~~

~~54.2 to ensure that the animal does not cause a nuisance, or breach the reasonable peace, comfort or privacy of neighbours, and~~

~~54.3 to ensure that the animal is registered and micro-chipped if required under law, and~~

~~54.4 to comply with any council requirements.~~

~~55. The tenant agrees to have the carpet professionally cleaned or to pay the cost of having the carpet professionally cleaned at the end of the tenancy if cleaning is required because an animal has been kept on the residential premises during the tenancy.~~

ADDITIONAL TERM - AGREEMENT TO USE PREVIOUS CONDITION REPORT

56. The landlord and tenant: *Rw*

56.1 agree that the condition report included in a residential tenancy agreement entered into by the tenant and dated *X. EK* 15 / 11 / 2019 (insert a date if the landlord and tenant agree to this clause) forms part of this agreement,

56.2 acknowledge that the tenant's responses in that condition report form part of this agreement, and *X. KV.*

56.3 agree that two physical copies of that condition report, or one electronic copy, have been given to the tenant on or before the date of this agreement.

ADDITIONAL TERM - TENANT'S CARE AND USE OF THE RESIDENTIAL PREMISES

57. Further to clauses 16 and 17 and subject to any applicable by-law, the tenant agrees:

- 57.1** to use the residential premises for residential purposes only;
57.2 not to use, advertise for use, sub-let, licence, transfer or otherwise part with possession of the whole or any part of the residential premises for the purpose of giving a person the right to occupy the residential premises for the purpose of a holiday, without the prior written consent of the landlord where such consent may be refused in the landlord's absolute discretion;
57.3 to clean the residential premises regularly with special attention to the kitchen, bathroom and appliances;
57.4 to put nothing down any sink, toilet or drain likely to cause obstruction or damage;
57.5 to wrap up and place garbage in a suitable container;
57.6 to regularly mow the lawns and keep the grounds and garden tidy and free of weeds and rubbish and maintain them in their condition, fair wear and tear excepted, as at the commencement of this agreement;
57.7 to take special care of the items let with the residential premises including any furniture, furnishings and appliances;
57.8 to do no decorating that involves painting, marking or defacing the residential premises or fixing posters without the prior written consent of the landlord or an order of the Civil and Administrative Tribunal;
57.9 to ensure that nothing is done that may prejudice any insurance policy or increase the premium payable under any insurance policy held by the landlord in relation to the residential premises and to ensure that nothing is done on the residential premises which may expose the owner to any claims or liability or which might give rise to an insurance claim;
57.10 to notify the landlord promptly of any infectious disease or the presence of rats, cockroaches, fleas or other pests;
57.11 to ventilate, in an adequate and timely manner and, if applicable, without any alteration or addition to the common property, all rooms and areas in the residential premises and to prevent the growth of mould;
57.12 not to remove, alter or damage any water efficiency measure installed in the residential premises;
57.13 not to store rubbish, unregistered vehicles, any inflammable, dangerous or hazardous chemical, liquid or gas (with the exception of petrol or gas stored in the fuel tank of any registered motor vehicle) or other inflammable, dangerous or hazardous material on the residential premises, and storage of any items on the residential premises is at the tenant's own risk; and
57.14 to take out and bring in, in accordance with the scheduled garbage collection days, and to keep clean, all bins that are supplied with the residential premises and to pay the cost of repair or replacement of any bins that become damaged, lost or stolen (if not repaired or replaced at the cost of the relevant authority) whilst the tenant is in occupation of the residential premises.

ADDITIONAL TERM - TELECOMMUNICATIONS SERVICES

58. The tenant agrees:

- 58.1** to leave, in the same manner of connection or operation, any telephone service installed in the residential premises at the commencement of this agreement; and

RESIDENTIAL TENANCY AGREEMENT

58.2 the availability of telephone or fax lines, internet services, analogue, digital or cable television (and the adequacy of such services) are the sole responsibility of the tenant and the tenant should make their own enquiries as to the availability and adequacy of such services before executing this agreement. The landlord does not warrant that any telephone or fax plugs, antenna sockets or other such sockets or service points located in the residential premises are serviceable, or will otherwise meet the requirements of the tenant, and tenants must rely upon their own enquiries. The landlord is not obliged to install any antenna, plugs or sockets including but not limited to any digital aerials or antennas or to carry out any upgrades in respect of television or internet reception on the residential premises.

ADDITIONAL TERM - RENT AND RENTAL BOND

59. The tenant agrees:

- 59.1** to pay the rent on or before the day which the term of this agreement begins; and
- 59.2** not to apply any rental bond towards payment of the rent without the prior written consent of the landlord.

60. The landlord and the tenant may, by agreement, change the manner in which rent is payable under this agreement.

ADDITIONAL TERM - OCCUPANTS

61. The tenant agrees:

- 61.1** not to part with possession other than in accordance with the provisions of this agreement or the *Residential Tenancies Act 2010*; and
- 61.2** to ensure that occupants and other persons who come on to the residential premises with the tenant's consent comply with the conditions of this agreement.

ADDITIONAL TERM - TERMINATION

62. The tenant acknowledges that a notice of termination does not by itself end the tenant's obligations under this agreement.

63. The tenant agrees:

- 63.1** upon termination of this agreement, to:
- promptly and peacefully deliver up vacant possession of the residential premises to the landlord by the date specified in the termination notice or otherwise in accordance with the *Residential Tenancies Act 2010*;
 - promptly notify the landlord or the landlord's agent of the tenant's forwarding address; and
 - comply with its obligations in clause 18 of this agreement; and

63.2 that the tenant's obligations under this agreement continue until such time as the tenant has provided vacant possession of the residential premises, left them in the condition required under this agreement and returned to the landlord or the landlord's agent all keys, access cards, locks and other opening devices and security items.

64. Notwithstanding any termination of this agreement, **the tenant acknowledges and agrees** that an application may be made to the Civil and Administrative Tribunal if the tenant does not vacate when required or otherwise does not comply with this agreement.

65. The landlord and the tenant agree that:

- 65.1** any action by the landlord or the tenant to terminate this agreement shall not affect any claim for compensation in respect of a breach of this agreement; and
- 65.2** the acceptance of or demand for rent or other money by the landlord after service of a termination notice for breach does not operate as a waiver of that notice nor does it evidence the creation of a new tenancy.

Note: Examples of where a fixed term agreement can be ended are where a party has breached the agreement (in which case the notice period is not less than 14 days) or where the rent has remained unpaid in breach of the agreement for not less than 14 days. Examples of where a periodic agreement can be ended are where a contract for sale of land requiring vacant possession has been exchanged (in which case the notice period is not less than 30 days), a party has breached the agreement (in which case the notice period is not less than 14 days) or where the rent has remained unpaid in breach of the agreement for not less than 14 days.

Note: If the tenant breaches this agreement the landlord should refer to section 87(2) of the *Residential Tenancies Act 2010*.

ADDITIONAL TERM - STATUTES, STRATA BY-LAWS, RULES AND SPECIAL CONDITIONS FOR FLATS

66. The tenant acknowledges and agrees:

- 66.1** to observe all relevant statutes, statutory regulations, strata by-laws, company title rules and community title rules relating to health, safety, noise and other housing standards with respect to the residential premises;
- 66.2** where the residential premises are subject to the *Strata Schemes Management Act 2015*, the *Strata Schemes Development Act 2015*, the *Community Land Development Act 1989* or the *Community Land Management Act 1989*, to observe and comply with any applicable strata by-laws and/or management statements and any applicable law;
- 66.3** where the residential premises are a flat (not subject to the *Strata Schemes Management Act 2015*, the *Strata Schemes Development Act 2015*, the *Community Land Development Act 1989* or the *Community Land Management Act 1989*), to comply with any applicable law and the special conditions contained in Schedule A of this agreement and any other special conditions as notified to the tenant from time to time; and
- 66.4** that, at the tenant's cost, the owners corporation or strata managing agent may dispose of abandoned goods, perishable goods or rubbish left on common property.

ADDITIONAL TERM - SWIMMING POOLS

(This clause does not apply when there is no pool on the residential premises)

~~67. Unless otherwise agreed by the landlord and tenant in writing, the tenant agrees:~~

~~67.1 to vacuum, brush and clean the pool, backwash the filter and empty the leaf basket(s) regularly, keeping them free from leaf litter and other debris;~~

~~67.2 to have the pool water tested once a month at a pool shop and to purchase and use the appropriate chemicals to keep the water clean and clear;~~

~~67.3 to keep the water level above the filter inlet at all times;~~

~~67.4 to notify the landlord or the landlord's agent as soon as practicable of any problems with the pool or equipment, safety gate, access door, fence or barrier;~~

~~67.5 not to interfere with the operation of any pool safety gate, access door, fence or barrier including not propping or holding open any safety gate or access door, nor leaving any item or object near a pool safety gate, access door, fence or barrier which would aid or allow children to climb the pool safety gate, access door, fence or barrier; and~~

~~67.6 to ensure that the pool safety gate or access door is self-closing at all times;~~

RESIDENTIAL TENANCY AGREEMENT

ADDITIONAL TERM – RENT INCREASES DURING THE FIXED TERM (for a fixed term of **less than 2 years**):

68. By completing this clause, **the parties agree** that the rent will be increased during the fixed term of the agreement as follows:

68.1 the rent will be increased to

\$		per	
	on	/ /	; and
to \$		per	
	on	/ /	; or

68.2 the rent increase can be calculated by the following method (set out details):

Note: The rent payable under a residential tenancy agreement may be increased only if the tenant is given written notice by the landlord or the landlord's agent specifying the increased rent and the day from which it is payable, and the notice is given at least 60 days before the increased rent is payable.

ADDITIONAL TERM – RENT INCREASES DURING THE FIXED TERM (for a fixed term of **2 years or more**):

69. By completing this clause, **the parties agree** that the rent will be increased during the fixed term of the agreement as follows:

69.1 the rent will be increased to

\$		per	
	on	/ /	; and
to \$		per	
	on	/ /	; or

69.2 the rent increase can be calculated by the following method (set out details):

Note: The rent payable under a residential tenancy agreement may be increased only if the tenant is given written notice by the landlord or the landlord's agent specifying the increased rent and the day from which it is payable, and the notice is given at least 60 days before the increased rent is payable.

Note: The rent payable under a fixed term agreement for a fixed term of 2 years or more must not be increased more than once in any period of 12 months, and may be increased whether or not the agreement sets out the amount of the increase or the method of calculating the increase.

ADDITIONAL TERM - CONDITION REPORT FORMS PART OF THIS AGREEMENT

70. For avoidance of doubt:

70.1 a condition report which accompanies this agreement, forms part of this agreement;

70.2 a condition report that is signed by both the landlord and the tenant is presumed to be a correct statement, in the absence of evidence to the contrary, of the state of repair or general condition of the residential premises on the day specified in the report; and

70.3 if the tenant fails to return the condition report to the landlord or the landlord's agent within 7 days of being provided with the landlord's signed condition report then the tenant is deemed to have accepted the landlord's signed condition report and that report forms part of this agreement.

ADDITIONAL TERM - ADDITIONAL TENANT OBLIGATIONS

71. The tenant agrees:

71.1 to reimburse the landlord, within 30 days of being requested to do so, for:

- any call out fees payable where the call out has been arranged with the tenant and the tenant has failed to provide access to the residential premises for any reason, preventing the relevant service from taking place;
- any cost or expense of any kind incurred by the landlord to replace or fix an item, fixture or fitting in or on the residential premises that was required to be replaced or fixed as a result of a fire audit or fire inspection, provided that the item, fixture or fitting needed replacing or fixing due to the activities carried out by the tenant in or on the residential premises (including, without limitation, creating holes in, or attaching hooks to, fire safety doors); and
- any fine, penalty or costs of any recovery action incurred by the landlord arising out of or in connection with the failure of a body corporate, community association or company to comply with a statutory requirement (including, without limitation, the lodgement of an annual fire safety statement) if that failure was caused or contributed to by the tenant;

71.2 to notify the landlord or the landlord's agent immediately if any smoke detector or smoke alarm in the residential premises is not working properly so that the landlord can attend to the landlord's obligation referred to in clause 42 of this agreement; and

71.3 to pay any call out fees payable to the fire brigade or other authorities which become payable in the event that a smoke alarm fitted to the residential premises is activated by activities carried out by the tenant on the residential premises, including but not limited to burning food.

ADDITIONAL TERM - TENANCY DATABASES

72. The landlord or the landlord's agent advises and the tenant acknowledges and agrees that the tenant's personal information may be collected, used and disclosed for the purpose of listing the tenant on a tenancy database as permitted by, and in accordance with, the provisions of the *Residential Tenancies Act 2010*.

ADDITIONAL TERM - GARAGE, STORAGE CAGE, OPEN CAR SPACE OR OTHER STORAGE FACILITY

[This clause does not apply if there is no garage, storage cage, open car space or other storage facility on the residential premises]

73. The tenant agrees that if the premises include a garage then the garage is provided for the purpose of parking a motor vehicle and not for the storage of goods or personal belongings.

74. The landlord gives no undertaking as to the security and/or waterproofing of any garage, storage cage, open car space or any other storage facility on the residential premises and accepts no liability for any damage to such garage, storage cage, open car space or other storage facility or to anything stored therein.

ADDITIONAL TERM - DETAILS OF TENANT AND TENANT'S AGENT

75. The tenant agrees to notify the landlord or the landlord's agent, in writing within 14 days, of any changes to the nominated contact details of the tenant or the tenant's agent, including those specified in this agreement.

76. The landlord agrees to provide to the tenant's agent (if appointed) all notices and documents that it gives to the tenant.

ADDITIONAL TERM - TENANT'S REFUSAL OF ACCESS

77. Where the tenant has been provided with the requisite notice pursuant to clause 24.8 and the tenant has refused access to the residential premises preventing prospective tenants from inspecting them, **the tenant acknowledges and agrees** that the landlord is entitled to claim damages for loss of bargain in the event the landlord is unable to secure a future tenant as a result of the tenant's refusal to allow access to the residential premises.

78. The tenant agrees that the landlord and the landlord's agent are authorised to use the office set of keys to access the residential premises for the purpose of carrying out an inspection pursuant to clause 24.

ADDITIONAL TERM - PRIVACY POLICY

79. The *Privacy Act 1988* (Cth) (the **Act**) allows certain information about the tenant referred to in this agreement to be collected, used and disclosed for the purpose for which it was collected, and otherwise in accordance with the Act. This Privacy Policy does not form part of this agreement and only applies to the extent that the landlord collects, uses and discloses personal information and is required by the Act to comply with the requirements of the Act. If the landlord appoints an agent to act for the landlord, then this Privacy Policy will apply to the landlord's agent's collection, use and disclosure of personal information on behalf of the landlord.

The landlord may amend, or amend and restate, this Privacy Policy from time to time and may subsequently notify the tenant of any changes to this Privacy Policy by written notification to the tenant. Any change to this Privacy Policy takes effect on the date of that written notification.

The personal information the tenant provides in connection with this agreement or collected from other sources is necessary for the landlord and (if appointed) the landlord's agent to:

- (a) identify and verify the tenant's identity;
- (b) process and assess any application received in relation to the lease of the residential premises;
- (c) assess the tenant's ability to meet their financial and other obligations under this agreement;
- (d) manage this agreement and the residential premises including (without limitation) the collection of rent and the preparation of required statements of accounts;
- (e) contact and liaise with goods and services providers as instructed by the tenant and to provide those providers with the tenant's personal information;
- (f) comply with any applicable law;
- (g) liaise and exchange information with the tenant and the legal and other advisors of the tenant, landlord and (if appointed) the landlord's agent in relation to or in connection with this agreement;
- (h) negotiate the lease for the residential premises;
- (i) process any payment (including, without limitation, the exchange of personal information with the relevant payment provider, where necessary); and
- (j) comply with any dispute resolution process.

If the personal information is not provided by the tenant, the landlord and (if appointed) the landlord's agent may not be able to carry out the steps described above.

Personal information collected about the tenant may be disclosed by the landlord or (if appointed) the landlord's agent for the purpose for which it was collected, to other parties including to the landlord (if the landlord's agent is appointed), the landlord's mortgagee or head-lessor (in either case, if any), the legal and other advisors of the tenant, landlord and (if appointed) the landlord's agent, referees, valuers, other agents, Courts and

applicable tribunals, third party operators of tenancy and other databases, other third parties instructed by the tenant (including, without limitation, goods, and services providers), as required by any applicable law and to any prospective or actual purchaser of the residential premises including to their prospective or actual mortgagee (if any). Personal information held by tenancy databases and relevant agencies may also be requested by and disclosed to the landlord and/or the landlord's agent. The landlord and (if appointed) the landlord's agent will take reasonable precautions to protect the personal information they hold in relation to the tenant from misuse, loss, and unauthorised access, modification or disclosure.

Further, if the tenant applies for the lease of the residential premises via any third party letting business, including any online letting businesses, then the tenant will have consented to the disclosure of its personal information by that business to the landlord and (if appointed) the landlord's agent. The tenant consents to the landlord and (if appointed) the landlord's agent receiving personal information from the relevant online letting business for the purposes specified in this Privacy Policy.

If the tenant fails to comply with its obligations under this agreement, then that fact and other relevant personal information collected about the tenant during the term of this agreement may also be disclosed to third party operators of tenancy and other databases, other agents, Courts and relevant tribunals.

The landlord and (if appointed) the landlord's agent may also use the tenant's information including personal information for marketing and research purposes to inform the tenant of products and services provided by the landlord and (if appointed) the landlord's agent, which the landlord and (if appointed) the landlord's agent consider may be of value or interest to the tenant, unless the tenant tells the landlord or (if appointed) the landlord's agent (see opt out option below) or has previously told the landlord or (if appointed) the landlord's agent not to. If the tenant **does not** wish to receive any information about such products and services then please tick this box: or otherwise notify the landlord and/or landlord's agent using the contact details of the landlord and/or landlord's agent (as applicable) set out earlier in this agreement.

The tenant has the right to request access to any personal information held by the landlord and (if appointed) the landlord's agent which relates to them, unless the landlord or (if appointed) the landlord's agent is permitted by law (including the Act) to withhold that information. If the Act applies to the landlord and the landlord is an 'organisation' (as defined under the Act) then it is entitled to charge a reasonable fee where access to personal information is provided (no fee may be charged for making an application to access personal information). If an agent is appointed by the landlord, it is entitled to charge a reasonable fee where access to personal information is provided (no fee may be charged for making an application to access personal information). Any requests for access to the tenant's personal information should be made in writing to the landlord or (if appointed) the landlord's agent at the contact details included in this agreement. The tenant has the right to request the correction of any personal information which relates to the tenant that is inaccurate, incomplete or out-of-date.

By signing this agreement, **the tenant acknowledges** that it has read and understands the terms of this Privacy Policy and agrees to those terms and the permissions to collect, use and disclose personal information, and **the tenant authorises** the landlord and (if appointed) the landlord's agent to collect, use and obtain, in accordance with the Act, their personal information for the purposes specified in this Privacy Policy.

ADDITIONAL TERM - ACKNOWLEDGEMENTS

80. The landlord and tenant each acknowledge that:

- 80.1** the landlord and tenant are permitted to agree on additional terms and conditions of this agreement and to include them in an annexure at the end of this agreement;
- 80.2** the additional terms and conditions may be included in this agreement only if:
 - (a) they do not contravene the *Residential Tenancies Act 2010* (NSW), the *Residential Tenancies Regulation 2019* (NSW) or any other Act; and
 - (b) they are not inconsistent with the standard terms and conditions of this agreement; and
- 80.3** The Real Estate Institute of New South Wales Limited (REINSW) is not and cannot be responsible for the drafting and content of any additional terms and/or conditions that are included in any annexure to this agreement.

SCHEDULE A**SPECIAL CONDITIONS - FLATS****Special Condition 1 - Vehicles**

The tenant must not park or stand any motor or other vehicle on common area, or permit a motor vehicle to be parked or stood on common area, except with the prior written approval of the landlord or as permitted by a sign authorised by the landlord.

Special Condition 2 - Damage to lawns and plants on the common areas

The tenant must not, except with the prior written approval of the landlord:

- (a) damage any lawn, garden, tree, shrub, plant or flower being part of or situated on the common area, or
- (b) use for his or her own purposes as a garden any portion of the common area.

Special Condition 3 - Obstruction of common areas

The tenant must not obstruct lawful use of common areas by any person except on a temporary and non-recurring basis.

Special Condition 4 - Noise

The tenant, or any invitee of the tenant, must not create any noise in the flat or the common area likely to interfere with the peaceful enjoyment of the owner or occupier of another flat or of any person lawfully using the common area.

Special Condition 5 - Behaviour of tenants and invitees

- (a) The tenant, or any invitee of the tenant, when on the common area must be adequately clothed and must not use language or behave in a manner likely to cause offence or embarrassment to the owner or occupier of another lot or to any person lawfully using the common area.
- (b) The tenant must take all reasonable steps to ensure that their invitees:
 - (i) do not behave in a manner likely to interfere with the peaceful enjoyment of the owner or occupier of another flat or any person lawfully using the common area; and
 - (ii) without limiting paragraph (b)(i), comply with Special Condition 5(a).

Special Condition 6 - Children playing on common areas in building

Any child for whom the tenant is responsible may play on any area of the common area that is designated by the landlord for that purpose but may only use an area designated for swimming while under adult supervision. The tenant must not permit any child of whom the tenant is responsible, unless accompanied by an adult exercising effective control, to be or to remain on the common area that is a laundry, car parking area or other area of possible danger or hazard to children.

Special Condition 7 - Smoke penetration

The tenant, and any invitee of the tenant, must not smoke tobacco or any other substance on the common area, except:

- (a) in an area designated as a smoking area by the landlord, or
- (b) with the written approval of the landlord.

The tenant who is permitted under this Special Condition to smoke tobacco or any other substance on common area must ensure that the smoke does not penetrate to any other flat. The tenant must ensure that smoke caused by the smoking of tobacco or any other substance by the tenant, or any invitee of the tenant, in the flat does not penetrate to the common area or any other flat.

Special Condition 8 - Preservation of fire safety

The tenant must not do any thing or permit any invitees to do any thing in the flat or common area that is likely to affect the operation of fire safety devices in the parcel or to reduce the level of fire safety in the flats or common areas.

Special Condition 9 - Storage of inflammable, dangerous or hazardous liquids and other substances and materials

- (a) The tenant must not, except with the prior written approval of the landlord, use or store in the flat, garage or carport or on the common area any inflammable, dangerous or hazardous chemical, liquid or gas or other inflammable, dangerous or hazardous material.
- (b) This Special Condition does not apply to chemicals, liquids, gases or other material used or intended to be used for domestic purposes, or any chemical, liquid, gas or other material in a fuel tank of a motor vehicle or internal combustion engine.

Special Condition 10 - Appearance of flat

- (a) The tenant must not, without the prior written approval of the landlord, maintain within the flat anything visible from outside the flat that, viewed from outside the flat, is not in keeping with the rest of the building.
- (b) This Special Condition does not apply to the hanging of any clothing, towel, bedding or other article of a similar type in accordance with Special Condition 12.

Special Condition 11 - Cleaning windows and doors

- (a) Except in circumstances referred to in Special Condition 11(b), the tenant is responsible for cleaning all interior and exterior surfaces of glass in windows and doors on the boundary of the flat, including so much as is common area.
- (b) The landlord is responsible for cleaning regularly all exterior surfaces of glass in windows and doors that cannot be accessed by the tenant safely or at all.

Special Condition 12 - Hanging out of washing

The tenant may hang any washing on any lines provided by the landlord for that purpose. The tenant may hang washing on any part of the flat other than over the balcony railings. In each case, the washing may only be hung for a reasonable period. In this Special Condition, "washing" includes any clothing, towel, bedding or other article of a similar type.

Special Condition 13 - Disposal of waste - bins for individual flats (applicable where individual flats have bins)

- (a) The tenant must:
 - (i) not deposit or throw on the common area any rubbish, dirt, dust or other material or discarded item except with the prior written approval of the landlord;
 - (ii) not deposit in a toilet, or otherwise introduce or attempt to introduce into the plumbing system, any item that is not appropriate for any such disposal (for example, a disposable nappy);
 - (iii) comply with all reasonable directions given by the landlord as to the disposal and storage of waste (including the cleaning up of spilled waste) on the common area;
 - (iv) comply with the local council's guidelines for the storage, handling, collection and disposal of waste;
 - (v) maintain bins for waste within the flat, or on any part of the common area that is authorised by the landlord, in clean and dry condition and appropriately covered;
 - (vi) not place any thing in the bins of the owner or occupier of any other flat except with the permission of that owner or occupier;
 - (vii) place the bins within an area designated for collection by the landlord not more than 12 hours before the time at which waste is normally collected and, when the waste has been collected, must promptly return the bins to the flat or other area authorised for the bins; and
 - (viii) notify the local council of any loss of, or damage to, bins provided by the local council for waste.

- (b) The landlord may give directions for the purposes of this Special Condition by posting signs on the common area with instructions on the handling of waste that are consistent with the local council's requirements or giving notices in writing to tenants.
- (c) In this Special Condition, "bin" includes any receptacle for waste and "waste" includes garbage and recyclable material.

**Special Condition 14 - Disposal of waste - shared bins
(applicable where bins are shared by flats)**

- (a) The tenant must:
 - (i) not deposit or throw on the common area any rubbish, dirt, dust or other material or discarded item except with the prior written approval of the landlord;
 - (ii) not deposit in a toilet, or otherwise introduce or attempt to introduce into the plumbing system, any item that is not appropriate for any such disposal (for example, a disposable nappy);
 - (iii) comply with all reasonable directions given by the landlord as to the disposal and storage of waste (including the cleaning up of spilled waste) on common area; and
 - (iv) comply with the local council's guidelines for the storage, handling, collection and disposal of waste.
- (b) The landlord may give directions for the purposes of this Special Condition by posting signs on the common area with instructions on the handling of waste that are consistent with the local council's requirements or giving notices in writing to tenants.
- (c) In this Special Condition, "bin" includes any receptacle for waste and "waste" includes garbage and recyclable material.

Special Condition 15 - Change in use or occupation of flat to be notified

- (a) The tenant must notify the landlord if the tenant changes the existing use of the flat.
- (b) Without limiting Special Condition 15(a), the following changes of use must be notified:
 - (i) a change that may affect the insurance premiums for the landlord (for example, if the change of use results in a hazardous activity being carried out in the flat, or results in the flat being used for commercial or industrial purposes rather than residential purposes); and
 - (i) a change to the use of the flat for short-term or holiday letting.
- (c) The notice must be given in writing at least 21 days before the change occurs or a lease or sublease commences.

Special Condition 16 - Compliance with planning and other requirements

The tenant must ensure that the flat is not used for any purpose that is prohibited by law and that the flat is not occupied by more persons than are allowed by law to occupy the flat.

NOTES.**1. Definitions**

In this agreement:

landlord means the person who grants the right to occupy residential premises under this agreement, and includes a successor in title to the residential premises whose interest is subject to that of the tenant and a tenant who has granted the right to occupy residential premises to a sub-tenant.

landlord's agent means a person who acts as the agent of the landlord and who (whether or not the person carries on any other business) carries on business as an agent for:

- (a) the letting of residential premises, or
- (b) the collection of rents payable for any tenancy of residential premises.

LFAI Register means the register of residential premises that contain or have contained loose-fill asbestos insulation that is required to be maintained under Division 1A of Part 8 of the *Home Building Act 1989*.

rental bond means money paid by the tenant as security to carry out this agreement.

residential premises means any premises or part of premises (including any land occupied with the premises) used or intended to be used as a place of residence.

tenancy means the right to occupy residential premises under this agreement.

tenant means the person who has the right to occupy residential premises under this agreement, and includes the person to whom such a right passes by transfer or operation of the law and a sub-tenant of the tenant.

2. Continuation of tenancy (if fixed term agreement)

Once any fixed term of this agreement ends, the agreement continues in force on the same terms as a periodic agreement unless the agreement is terminated by the landlord or the tenant in accordance with the *Residential Tenancies Act 2010* (see notes 3 and 4).

Clauses 5 and 6 of this agreement provide for rent to be able to be increased if the agreement continues in force, with certain restrictions.

3. Ending a fixed term agreement

If this agreement is a fixed term agreement it may be ended by the landlord or the tenant by giving written notice of termination. The notice may be given at any time up until the end of the fixed term but cannot take effect until the term ends. The landlord must give at least 30 days notice and the tenant must give at least 14 days notice.

4. Ending a periodic agreement

If this agreement is a periodic agreement it may be ended by the landlord or the tenant by giving written notice of termination. The notice may be given at any time. The landlord must give at least 90 days notice and the tenant must give at least 21 days notice.

5. Other grounds for ending agreement

The *Residential Tenancies Act 2010* also authorises the landlord and tenant to end this agreement on other grounds. The grounds for the landlord ending the agreement include sale of the residential premises requiring vacant possession, breach of this agreement by the tenant, due to hardship or if the agreement is frustrated because the premises are destroyed, become wholly or partly uninhabitable or cease to be lawfully usable as a residence or are appropriated or acquired by any authority by compulsory process.

The grounds for the tenant include breach by the landlord of information disclosure provisions under section 26 of the Act (not revealed when this agreement was entered into), breach of this agreement by the landlord, due to hardship or if the agreement is frustrated because the premises are destroyed, become wholly or partly uninhabitable or cease to be lawfully usable as a residence or are appropriated or acquired by any authority by compulsory process.

For more information refer to that Act or contact NSW Fair Trading on 13 32 20.

6. Warning

It is an offence for any person to obtain possession of the residential premises without an order of the Civil and Administrative Tribunal or a judgment or order of a court if the tenant does not willingly move out. A court can order fines and compensation to be paid for such an offence.

RESIDENTIAL TENANCY AGREEMENT

THE LANDLORD AND THE TENANT ENTER INTO THIS AGREEMENT AND AGREE TO ALL ITS TERMS.

Note. Section 9 of the *Electronic Transactions Act 2000* allows for agreements to be signed electronically in NSW if the parties consent. If an electronic signature is used then it must comply with Division 2 of Part 2 of the *Electronic Transactions Act 2000*.

SIGNED BY THE LANDLORD / LANDLORD'S AGENT

R Allwood
(Signature of landlord/landlord's agent)

11/1/21
(Date)

LANDLORD INFORMATION STATEMENT

The landlord acknowledges that, at or before the time of signing this residential tenancy agreement, the landlord has read and understood the contents of an information statement published by NSW Fair Trading that sets out the landlord's rights and obligations.

R Allwood
(Signature of landlord/landlord's agent)

11/1/21
(Date)

Note: A landlord's agent must not sign this acknowledgment unless they have first obtained from the landlord a written statement that the landlord has read and understood the contents of the information statement published by NSW Fair Trading setting out the landlord's rights and obligations.

SIGNED BY THE TENANT

Esoom Korava
(Signature of tenant)

15/1/2021
(Date)

(Signature of tenant)

(Date)

[Signature]
(Signature of tenant)

15/1/2021
(Date)

(Signature of tenant)

(Date)



TENANT INFORMATION STATEMENT

The tenant acknowledges that, at or before the time of signing this residential tenancy agreement, the tenant was given a copy of an information statement published by NSW Fair Trading.

Esoom Korava
(Signature of tenant)

15/1/2021
(Date)

(Signature of tenant)

(Date)

[Signature]
(Signature of tenant)

15/1/2021
(Date)

(Signature of tenant)

(Date)



For information about your rights and obligations as a landlord or tenant, contact:

- (a) NSW Fair Trading on 13 32 20 or www.fairtrading.nsw.gov.au, or
- (b) Law Access NSW on 1300 888 529 or www.lawaccess.nsw.gov.au, or
- (c) your local Tenants Advice and Advocacy Service at www.tenants.org.au

Tenant information statement

What you must know before you start renting

Starting a tenancy

Landlords or agents must give all tenants a copy of this **Tenant information statement** before signing a residential tenancy agreement.

Make sure you read this information statement thoroughly before you sign a residential tenancy agreement. Ask questions if there is anything in the agreement that you do not understand.

Remember, you are committing to a legally binding contract with no cooling-off period. You want to be certain you understand and agree to what you are signing.

The landlord or agent must:

- ensure the property is vacant, reasonably clean, fit to live in and in good repair at the start of the tenancy
- provide and maintain the property in a reasonable state of repair
- meet health and safety laws (e.g. pool fencing, electrical installations, smoke alarms, window and balcony safety)
- ensure the property is reasonably secure
- respect your privacy and follow entry and notice requirements.

When renting, you must:

- pay the rent on time
- keep the property reasonably clean and undamaged and leave it in the same condition it was in when you moved in (fair wear and tear excepted)
- not use the property for anything illegal
- follow the terms of the tenancy agreement
- respect your neighbours' right to peace, comfort and privacy

What you must be told before you sign an agreement

Sometimes a rental property has something in its history that you should know before you sign an agreement.

The landlord or agent **must tell** you if the property is:

- planned to be sold
- subject to court proceedings where the mortgagee is trying to take possession of the property
- in a strata scheme and a strata renewal committee is currently established for the strata scheme.

The landlord or agent **must tell** you if they are aware of any of the following facts. If the property:

- has been subject to flooding from a natural weather event or bushfire in the last 5 years
- has significant health or safety risks (unless obvious to a reasonable person when the property is inspected)
- has been the scene of a serious violent crime (e.g. murder or aggravated assault) in the last 5 years
- is listed on the [loose-fill asbestos insulation register](#)
- has been used to manufacture or cultivate a prohibited drug or prohibited plant in the last 2 years
- is part of a building where a fire safety or building product rectification order (or a notice of intention to issue one of these orders) has been issued regarding external combustible cladding
- is part of a building where a development or complying development certificate application for rectification has been lodged regarding external combustible cladding
- is in a strata scheme where scheduled rectification work or major repairs will be carried out to common property during the fixed term of the agreement
- is affected by zoning or laws that will not allow you to obtain a parking permit, and only paid parking is available in the area
- is provided with any council waste services that are different to other properties in the council area
- has a driveway or walkway that others can legally use.

Penalties apply to landlords or agents if any of the above is not done.

What you must be given before you sign an agreement

Before you sign an agreement or move into the property, the landlord or agent **must give** you:

- a copy of this Tenant information statement
- a copy of the proposed tenancy agreement, filled out in the spaces provided
- 2 hard copies, or 1 electronic copy, of the condition report for the property completed by the landlord or agent
- a copy of the by-laws, if the property is in a strata scheme.

What you must be given at the time you sign an agreement

At the time you sign the agreement, the landlord or agent **must give** you:

- for any swimming or spa pools on the property, a valid certificate of compliance or occupation certificate (issued within the last 3 years). This does not apply if you are renting a property in a strata or community scheme that has more than 2 lots.

Before or at the start of the tenancy

The landlord or agent **must give** you:

- a copy of the key (or other opening device or information) to open any lock or security device for the rented property or common property, at no cost to you or any tenant named in the agreement

The property must be fit to live in

The property must be reasonably clean, fit to live in and in a reasonable state of repair.

To be fit to live in, the property must (at a minimum):

1. be structurally sound
2. have adequate natural or artificial lighting in each room, except storage rooms or garages
3. have adequate ventilation
4. be supplied with electricity or gas, and have enough electricity or gas sockets for lighting, heating and other appliances
5. have adequate plumbing and drainage
6. have a water connection that can supply hot and cold water for drinking, washing and cleaning
7. have bathroom facilities, including toilet and washing facilities, that allow users' privacy.

The property could have other issues that may make it unfit for you to live in, even if it meets the

above 7 minimum standards. Before you rent the property, you should tell the landlord or agent to take steps (such as make repairs) to make sure the property is fit to live in.

Residential tenancy agreement

The tenancy agreement is a legal agreement. It must include certain standard terms that cannot be changed or deleted. It may also include additional terms. Verbal agreements are still binding on you and the landlord.

Condition report

You should have already received a copy of the condition report, completed by the landlord or agent, before you signed the agreement. This is an important piece of evidence and you should take the time to check the condition of the property at the start of the tenancy. If you do not complete the report accurately, money could be taken out of your bond (after you move out) to pay for damage that was already there when you moved in.

You must complete and give a copy of the condition report to your landlord or agent **within 7 days** after moving into the property. You must also keep a copy of the completed report.

Rent, receipts and records

Rent is a regular payment you make to the landlord to be able to live in the property. You cannot be asked to pay more than 2 weeks' rent in advance. Your landlord or agent cannot demand more rent until it is due.

Your landlord or agent can serve you with 14 days' termination notice if you are more than 14 days behind with the rent.

Your landlord or agent must:

- give you rent receipts (unless rent is paid into a nominated bank account)
- keep a record of rent you pay
- provide you with a copy of the rent record within 7 days of your written request for it.

Rental bonds

The bond is money you may have to pay at the start of the tenancy as security. It must be in the form of money and not as a guarantee. Your landlord or agent can only ask for 1 bond for a tenancy agreement. The bond payable cannot be more than 4 weeks rent. If the landlord agrees, you can pay the bond in instalments.

Your landlord or agent cannot make you pay a bond before the tenancy agreement is signed. If you pay the bond directly to Fair Trading using [Rental Bonds Online](#) (RBO) the landlord or agent will receive confirmation of this before they finalise the tenancy agreement.

Your landlord or agent must give you the option to use RBO to pay your bond. You can use RBO to securely pay your bond direct to NSW Fair Trading using a credit card or BPAY, without the need to fill out and sign a bond lodgement form. Once registered, you can continue to use your RBO account for future tenancies.

If you decide not to use RBO, you can ask your agent or landlord for a paper bond lodgement form for you to sign, so that it can be lodged with Fair Trading. The landlord must deposit any bond you pay them with Fair Trading within 10 working days. If the bond is paid to the agent, the agent must deposit the bond with Fair Trading within 10 working days after the end of the month in which the bond was paid.

Discrimination when applying for rental property

It is against the law for a landlord or agent to discriminate on the grounds of your race, age, disability, gender, sexual orientation, marital status or pregnancy.

If you feel that a landlord or agent has declined your tenancy application or has treated you less favourably because of the above, you can contact the NSW Anti-Discrimination Board on 1800 670 812 or the Australian Human Rights Commission on 1300 656 419.

It is not against the law if a landlord or agent chooses not to have a tenant who smokes, or has a poor tenancy history or issues with rent payments.

Communicating with your landlord or agent

Your landlord must provide you with their name and a way for you to contact them directly, even if your landlord has an agent.

This information must be given to you in writing before or when you sign the tenancy agreement, or it can be included in the agreement you sign. Your landlord must also let you know, in writing, within 14 days of any changes to their details.

Some formal communication between you and the landlord or agent must be in writing to be valid, for example, termination notices. You can use email to serve notices or other documents but only if the landlord or agent has given you permission to use their nominated email address for this purpose.

During the tenancy

Can rent be increased during the tenancy?

For a fixed-term of less than 2 years, rent can only be increased during the fixed-term if the agreement sets out the increased amount or how the increase will be calculated. No written notice of the increase is required.

For a fixed-term of 2 years or more, or for a periodic agreement (i.e. where the fixed-term has expired or no fixed-term is specified), the rent can only be increased once in a 12-month period. You must get at least 60 days written notice.

Paying for electricity, gas and water usage

You may have to pay the cost for certain utilities as set out in the agreement. For example, you will pay for all:

- electricity, non-bottled gas or oil supply charges **if** the property is separately metered. Some exceptions apply for electricity or gas
- charges for the supply of bottled gas during the tenancy.

There are limits on when you need to pay for water usage charges. You can only be asked to pay for water usage if the property is separately metered (or water is delivered by vehicle) and meets the following water efficiency measures:

- all showerheads have a maximum flow rate of 9 litres per minute
- all internal cold-water taps and single mixer taps for kitchen sinks or bathroom hand basins have a maximum flow rate of 9 litres per minute
- any leaking taps or toilets on the property are fixed at the start of the agreement and whenever other water efficiency measures are installed, repaired or upgraded
- from 23 March 2025, toilets are dual flush and have a minimum 3-star WELS rating.

Repairs and maintenance

The property must always be fit for you to live in. The landlord is responsible for any repairs or maintenance, so the property is in a reasonable state of repair. They must also ensure the property meets health and safety laws.

You are responsible for looking after the property and keeping it clean and undamaged. If the property includes a yard, lawns and gardens, you must also keep these areas neat and tidy.

You need to tell your landlord or the agent of any necessary repairs or damage as soon as possible. They are responsible for arranging and paying for the repair costs unless you caused or allowed the damage. You are not responsible for any damage caused by a perpetrator of domestic violence during a domestic violence offence.

If the repair is an **urgent repair** e.g. where there is a burst water service, a blocked or broken toilet, a gas leak or dangerous electrical fault, your landlord or agent should organise these repairs as soon as reasonably possible, after being notified. If they do not respond to an urgent repair, you may be able to organise the work yourself and be reimbursed

a maximum amount of \$1,000 within 14 days from requesting payment in writing. A list of **urgent repairs** is available on the [Fair Trading website](#).

You can apply to Fair Trading for a rectification order if your landlord refuses or does not provide and maintain the property in a reasonable state of repair. Similarly, your landlord can apply to Fair Trading for a rectification order if you refuse or do not repair damage you have caused or allowed. You can also apply to the NSW Civil and Administrative Tribunal (the Tribunal) if your landlord does not carry out repairs.

Smoke alarms must be working

Landlords must ensure that smoke alarms are installed on all levels of the property. Your landlord must maintain the smoke alarms in your property to ensure they are working.

You should notify your landlord or agent if a smoke alarm is not working. They are responsible for repairing (including replacing a battery) or replacing a smoke alarm within 2 business days after they become aware that it is not working.

You can choose to replace a removable battery if it needs replacing, but you must notify the landlord if and when you do this. You are not responsible for maintaining, repairing or replacing a smoke alarm. However, there are some circumstances where you can arrange for a smoke alarm to be repaired or replaced.

Privacy and access

You have the right to reasonable peace, comfort and privacy when renting. Tenancy laws restrict when and how often your landlord, agent or other authorised person can enter the property during the tenancy. Your landlord, agent or authorised person can enter the property without your consent in certain circumstances if proper notice (if applicable) is provided.

For example:

- in an **emergency**, no notice is necessary
- if the **Tribunal orders** that access is allowed
- to carry out, or assess the need for, **necessary repairs or maintenance** of the property, if you have been given at least 2 days' notice
- to carry out **urgent repairs**, no notice is necessary
- to carry out **repairs or replacement of a smoke alarm**, if you have been given at least 1 hours' notice
- to **inspect or assess the need for repair or replacement of a smoke alarm**, if you have been given at least 2 business days' notice
- to carry out a **general inspection** of the property if you have been given at least 7 days' written notice (no more than 4 inspections during a 12-month period).

How to make 'minor' changes to the property

You can only make minor changes to the property with your landlord's written consent, or if the agreement allows it. Your landlord can only refuse your request if it is reasonable to do so e.g. if the work involves structural changes or is inconsistent with the nature of the property.

There are certain types of 'minor' changes where it would be unreasonable for your landlord to refuse consent. For example:

- secure furniture to a non-tiled wall for safety reasons
- fit a childproof latch to an outdoor gate in a single dwelling
- insert fly screens on windows
- install or replace internal window covering (e.g. curtains)
- install cleats or cord guides to secure blind or curtain cords
- install child safety gates inside the property
- install window safety devices for child safety (non-strata only)
- install hand-held shower heads or lever-style taps to assist elderly or disabled occupants
- install or replace hooks, nails or screws for hanging pictures etc.
- install a phone line or internet connection
- plant vegetables, flowers, herbs or shrubs in the garden
- install wireless removable outdoor security camera
- apply shatter-resistant film to window or glass doors
- make changes that don't penetrate a surface, or permanently modify a surface, fixture or structure of the property.

Some exceptions apply. The landlord can also require that certain minor changes be carried out by a qualified person.

You will be responsible for paying for the changes and for any damage you cause to the property. Certain rules apply for removing any modifications at the end of the tenancy.

Your rights in circumstances of domestic violence

Every person has the right to feel safe and live free from domestic violence. If you or your dependent child are experiencing domestic violence in a rental property, there are options available to you to improve your safety.

If you or your dependent child need to escape violence, you can end your tenancy immediately,

without penalty. To do this you must give your landlord a termination notice with the relevant evidence and give a termination notice to any co-tenants.

Or, if you wish to stay in your home, you can apply to the Tribunal for an order to end the tenancy of the perpetrator (if they are another co-tenant).

A tenant or any innocent co-tenant is not liable for property damage caused by the perpetrator of violence during a domestic violence offence.

Ending the tenancy

Termination notice must be given

A tenancy agreement is a legally binding agreement that can only be ended in certain ways. A tenancy will usually be ended by you or your landlord giving notice to the other party and you vacating on or after the date specified in the notice.

To end a tenancy, you need to give the landlord or agent a written termination notice with the applicable notice period. In some cases, you can apply directly to the Tribunal for a termination order without issuing a termination notice (for example if you are experiencing hardship).

If you do not leave by the date specified in the termination notice, the landlord or agent can apply to the Tribunal for termination and possession orders. If you do not comply with the Tribunal order, only a Sheriff's Officer can legally remove you from the property under a warrant for possession.

You cannot be locked out of your home under any circumstances unless a Sheriff's Officer is enforcing a warrant for possession issued by the Tribunal or a court.

Break fee for ending a fixed term agreement early

If you end a fixed term agreement early that is for 3 years or less, mandatory break fees may apply based on the stage of the agreement. If it applies, the set fee payable will be:

- 4 weeks rent if less than 25% of the lease had expired
- 3 weeks rent if 25% or more but less than 50% of the lease had expired
- 2 weeks rent if 50% or more but less than 75% of the lease had expired
- 1 week's rent if 75% or more of the lease had expired.

The break fee does not apply if you end the agreement early for a reason allowed under the Act.

Getting the rental bond returned

You should receive the bond in full at the end of the tenancy unless there is a reason for the landlord to make a claim against the bond. For example if:

- rent or other charges (e.g. unpaid water usage bills, break fee) are owing
- copies of the keys were not given back and the locks needed to be changed
- you caused damage or did not leave the property in a reasonably clean condition compared to the original condition report, apart from 'fair wear and tear'.

You are not liable for fair wear and tear to the property that occurs over time with the use of the property, even when the property receives reasonable care and maintenance.

* Checklist

You should only sign the agreement when you can answer **Yes** to the following.

The tenancy agreement

- I have read the agreement and asked questions if there were things I did not understand.
- I understand the fixed-term of the agreement is negotiated before I sign, which means it can be for 6 months, 12 months, or some other period.
- I understand that I must be offered at least one way to pay the rent that does not involve paying a fee to a third party.
- I understand that any additional terms to the agreement can be negotiated before I sign.
- I have checked that all additional terms to the agreement are allowed. For example, the agreement does not include a term requiring me to have the carpet professionally cleaned when I leave, unless it is required because the landlord has allowed me to keep a pet on the property.

Promised repairs

For any promises the landlord or agent makes to fix anything (e.g. replace the oven, etc.) or do other work (e.g. paint a room, clean up the backyard, etc.):

- I have made sure these have already been done or
- I have an undertaking in writing (before signing the agreement) that they will be done.

X. Esuou Koraeen

X. Kefan,



Upfront costs

- I am **not** required to pay:
 - more than 2 weeks rent in advance
 - more than 4 weeks rent as a rental bond.
- I am **not** being charged for:
 - the cost of preparing the tenancy agreement
 - the initial supply of keys and other opening devices to each tenant named in the agreement
 - being allowed to keep a pet on the property.

Top tips for problem-free renting

Some useful tips to help avoid problems when renting:

- Keep a copy of your agreement, condition report, rent receipts, Rental Bond Number and copies of letters/emails you send or receive in a safe place where you can easily find them later.
- Photos are a great way to record the condition of the property when you first move in. Take date-stamped photos of the property, especially areas that are damaged or unclean. Keep these photos in case the landlord objects to returning your bond at the end of your tenancy.
- Comply with the terms of your agreement and never stop paying your rent, even if you don't think the landlord is complying with their side of the agreement (e.g. by failing to do repairs). You could end up being evicted if you do.
- Never make any changes to the property, or let other people move in without asking the landlord or agent for permission first.
- Keep a written record of your dealings with the landlord or agent (for example by keeping copies of emails or a diary record of your conversations, including the times and dates, who you spoke to and what they agreed to do). It is helpful to have any agreements in writing, for example requests for repairs. This is a useful record and can also assist if there is a dispute.

- Consider taking out home contents insurance to cover your belongings in case of theft, fires and natural disasters. The landlord's building insurance, if they have it, will not cover your belongings.
- If the property has a pool or garden, be clear about what the landlord or agent expects you to do to maintain them.
- Be careful with what you sign relating to your tenancy and do not let anybody rush you. Never sign a blank form, such as a 'Claim for refund of bond' form.
- If you are happy in the property and your agreement is going to end, consider asking for the agreement to be renewed for another fixed-term. This will remove any worry about being unexpectedly asked to leave and can help to lock in the rent for the next period.

More information

Visit the [Fair Trading website](https://www.fairtrading.nsw.gov.au) or call 13 32 20 for more information about your renting rights and responsibilities. The NSW Government funds a range of community-based Tenants Advice and Advocacy Services across NSW to provide advice, information and advocacy to tenants. Visit the Tenants' Union website at [tenants.org.au](https://www.tenants.org.au)

[fairtrading.nsw.gov.au](https://www.fairtrading.nsw.gov.au)

13 32 20

Language assistance 13 14 50

(ask for an interpreter in your language)

© State of New South Wales (NSW Fair Trading), 2020

Creative Commons Attribution 4.0 licence.

For information: [fairtrading.nsw.gov.au/copyright](https://www.fairtrading.nsw.gov.au/copyright)

This publication must not be relied on as legal advice.

For more information about this topic, refer to the appropriate legislation.

X. Emani Kouran

X. [Signature]



ALL STRATA SERVICES

A DIVISION OF ALL TITLES MANAGEMENT SERVICES PTY LTD ACN 002 238 803

Ph [02] 4334-1499 Fax [02] 4334-3443 AH Emergency 0428 299670
PO Box 403 The Entrance NSW 2261 1 Orana Ave Blue Bay NSW 2261

istm

MEMBER OF THE INSTITUTE OF
STRATA TITLE MANAGEMENT

1 KING STREET
OURIMBAH

STRATA SCHEMES MANAGEMENT ACT 1996 SCHEDULE 1 BY-LAWS - RESIDENTIAL SCHEMES

1 Noise

An owner or occupier of a lot must not create any noise on the parcel likely to interfere with the peaceful enjoyment of the owner or occupier of another lot of any person lawfully using common property.

2 Vehicles

An owner or occupier of a lot must not park or stand any motor or other vehicle on common property except with the written approval of the owners corporation.

3 Obstruction of common property

An owner or occupier of a lot must not obstruct lawful use of common property by any person except on a temporary and non-recurring basis.

4 Damage to lawns and plants on common property

1. An owner or occupier of a lot must not, except with the prior written approval of the owners corporation: damage any lawn, garden, tree, shrub, plant or flower being part of or situated on common property, or
2. use for his or her own purposes as a garden any portion of the common property.

5 Damage to common property

1. An owner or occupier of a lot must not mark, paint, drive nails or screws or the like into, or otherwise damage or deface, any structure that forms part of the common property except with the prior written approval of the owners corporation.
2. An approval given by the owners corporation under subclause (1) cannot authorise any additions to the common property.
3. This by-law does not prevent an owner or person authorised by an owner from installing:
 - a. any locking or other safety device for protection of the owner's lot against intruders or to improve safety within the owner's lot, or
 - b. any screen or other device to prevent entry of animals or insects on the lot, or
 - c. any structure or device to prevent harm to children, or
 - d. any device used to affix decorative items to the internal surfaces of walls in the owner's lot.
4. Any such locking or safety device, screen, other device or structure must be installed in a competent and proper manner and must have an appearance, after it has been installed, in keeping with the appearance of the rest of the building.
5. Despite section 62, the owner of a lot must:
 - a. maintain and keep in a state of good and serviceable repair any installation or structure referred to in subclause (3) that forms part of the common property and that services the lot, and
 - b. repair any damage caused to any part of the common property by the installation or removal of any locking or safety device, screen, other device or structure referred to in subclause (3) that forms part of the common property and that services the lot.

6 Behaviour of owners and occupiers

An owner or occupier of a lot when on common property must be adequately clothed and must not use language or behave in a manner likely to cause offence or embarrassment to the owner or occupier of another lot or to any person lawfully using common property.

7 Children playing on common property in building

An owner or occupier of a lot must not permit any child of whom the owner or occupier has control to play on common property within the building or, unless accompanied by an adult exercising effective control, to be or to remain on common property comprising a laundry, car parking area or other area of possible danger or hazard to children.

8 Behaviour of invitees

An owner or occupier of a lot must take all reasonable steps to ensure that invitees of the owner or occupier do not behave in a manner likely to interfere with the peaceful enjoyment of the owner or occupier of another lot or any person lawfully using common property.

9 Depositing rubbish and other material on common property

An owner or occupier of a lot must not deposit or throw on the common property any rubbish, dirt, dust or other material or discarded item except with the prior written approval of the owners corporation.

10 Drying of laundry items

An owner or occupier of a lot must not, except with the prior written approval of the owners corporation, hang any washing, towel, bedding, clothing or other article on any part of the parcel in such a way as to be visible from outside the building other than on any lines provided by the owners corporation for the purpose and there only for a reasonable period.

11 Cleaning windows and doors

An owner or occupier of a lot must keep clean all exterior surface of glass in windows and doors on the boundary of the lot, including so much as is common property, unless:

1. the owners corporation resolves that it will keep the glass or specified part of the glass clean, or
2. that glass or part of the glass cannot be accessed by the owner or occupier of the lot safely or at all.

12 Storage of inflammable liquids and other substances and materials

1. An owner or occupier of a lot must not, except with the prior written approval of the owners corporation, use or store on the lot or on the common property any inflammable chemical, liquid or gas or other inflammable material.
2. This by-law does not apply to chemicals, liquids, gases or other material used or intended to be used for domestic purposes, or any chemical, liquid, gas or other material in a fuel tank of a motor vehicle or internal combustion engine.

All Strata Services
Schedule 1 Bylaws - Residential Schemes

13 Moving furniture and other objects on or through common property

1. An owner or occupier of a lot must not transport any furniture or large object through or on common property within the building unless sufficient notice has first been given to the executive committee so as to enable the executive committee to arrange for its nominee to be present at the time when the owner or occupier does so.
2. An owners corporation may resolve that furniture or large objects are to be transported through or on the common property (whether in the building or not) in a specified manner.
3. If the owners corporation has specified, by resolution, the manner in which furniture or large objects are to be transported, an owner or occupier of a lot must not transport any furniture or large object through or on common property except in accordance with that resolution.

14 Floor coverings

1. An owner of a lot must ensure that all floor space within the lot is covered or otherwise treated to an extent sufficient to prevent the transmission from the floor space of noise likely to disturb the peaceful enjoyment of the owner or occupier of another lot.
2. This by-law does not apply to floor space comprising a kitchen, laundry, lavatory or bathroom.

15 Garbage disposal

An owner or occupier of a lot in a strata scheme that does not have shared receptacles for garbage and recyclable materials or waste:

- a. must maintain such receptacles within the lot, or on such part of the common property as may be authorised by the owners corporation, in clean and dry condition and (except in the case of receptacles for recyclable material) adequately covered, and
- b. must ensure that before refuse, recyclable material or waste is placed in the receptacles it is, in the case of refuse, securely wrapped or, in the case of tins or other containers, completely drained, or, in the case of recyclable material or waste, separated and prepared in accordance with the recycling guidelines, and
- c. for the purpose of having the garbage, recyclable material or waste collected, must place the receptacles within an area designated for that purpose by the owners corporation and at a time not more than 12 hours before the time at which garbage, recyclable material or waste is normally collected, and
- d. when the garbage, recyclable material or waste has been collected, must promptly return the receptacles to the lot or other area referred to in paragraph (1), and
- e. must not place any thing in the receptacles of the owner or occupier of any other lot except with the permission of that owner or occupier, and
- f. must promptly remove any thing which the owner, occupier or garbage or recycling collector may have spilled from the receptacles and must take such action as may be necessary to clean the area within which that thing was spilled.

16 Keeping of animals

Option A

1. Subject to section 49(4), an owner or occupier of a lot must not, without the prior written approval of the owners corporation, keep any animal (except fish kept in a secure aquarium on the lot) on the lot or the common property.
2. The owners corporation must not unreasonably withhold its approval of the keeping of an animal on a lot or the common property.

Option B

1. Subject to section 49(4), an owner or occupier of a lot must not, without the prior written approval of the owners corporation, keep any animal (except a cat, a small dog, or a small caged bird, or a fish kept in a secure aquarium on the lot) on the lot or common property.
2. The owners corporation must not unreasonably withhold its approval to the keeping of an animal on a lot or the common property.
3. If an owner or occupier of a lot keeps a cat, small dog or a small caged bird on the lot then the owner or occupier must:
 - a. notify the owners corporation that the animal is being kept on the lot, and
 - b. keep the animal within the lot, and
 - c. carry the animal when it is on the common property, and
 - d. Take such action as may be necessary to clean all areas of the lot or the common property that are soiled by the animal.

Option C

Subject to section 49(4), an owner or occupier of a residential lot must not keep any animal on the lot or the common property.

17 Appearance of lot

1. The owner or occupier of a lot must not, without the prior written approval of the owners corporation, maintain within the lot anything visible from outside the lot that, viewed from outside the lot, is not in keeping with the rest of the building.
2. This by-law does not apply to the hanging of any washing, towel, bedding, clothing or other article as referred to in by-law 10.

18 Change in use of lot to be notified

An occupier of a lot must notify the owners corporation if the occupier changes the existing use of the lot in a way that may affect the insurance premiums for the strata scheme (for example, if the change of use results in a hazardous activity being carried out on the lot, or results in the lot being used for commercial or industrial purposes rather than residential purposes).

19 Provision of amenities or services

1. the owners corporation may, by special resolution, determine to enter into arrangements for the provision of the following amenities or services to one or more of the lots, or to the owners or occupiers of one or more of the lots:
 - a. window cleaning,
 - b. garbage disposal and recycling services,
 - c. electricity, water or gas supply,
 - d. telecommunication services (for example, cable television).
2. If the owners corporation makes a resolution referred to in subclause (1) to provide an amenity or service to a lot or to the owner or occupier of a lot, it must indicate in the resolution the amount for which, or the conditions which, it will provide the amenity or service.

Note : Section 111 of the Act provides that an owners corporation may enter into an agreement with an owner or occupier of a lot for the provision of amenities or services by it to the lot or to the owner or occupier.