

JOSEPH ALLAN BOWDEN and SHARON GAYE BOWDEN
(Vendors)

**CONTRACT OF SALE OF REAL ESTATE and
SECTION 32 VENDORS STATEMENT**

Ppty: 13 Mulberry Parade, Heidelberg West VIC 3081

PERFECT CHOICE CONVEYANCING SERVICES

820 Pascoe Vale Road, Glenroy VIC 3046

Tel: (03) 9304-1070

Fax: (03) 9304-1071

Mob: 0417-567-968

Email: info@pcconveyancing.com.au

CONTRACT OF SALE OF REAL ESTATE

Part 1 of the form of contract published by the Law Institute of Victoria Limited and The Real Estate Institute of Victoria Ltd

Ppty: 13 Mulberry Parade, Heidelberg West VIC 3081

The vendor agrees to sell and the purchaser agrees to buy the property, being the land and the goods, for the price and on the terms set out in this contract.

The terms of this contract are contained in the-

- particulars of sale; and
 - special conditions, if any; and
 - general conditions
- and in that order of priority.

SIGNING OF THIS CONTRACT

WARNING: THIS IS A LEGALLY BINDING AGREEMENT. YOU SHOULD READ THIS CONTRACT BEFORE SIGNING IT.

Purchasers should ensure that, prior to signing this contract, they have received –

- a copy of the Section 32 Statement required to be given by a Vendor under Section 32 of the *Sale of Land Act 1962* in accordance with Division 2 of Part II of that Act; and
- a copy of the full terms of this Contract

The authority of a person signing-

- under power of attorney; or
- as director of a corporation; or
- as agent authorised in writing by one of the parties -

must be noted beneath the signature.

Any person whose signature is secured by an estate agent acknowledges being given by the agent at the time of signing a copy of the terms of this contract.

SIGNED BY THE PURCHASER

..... on/...../20__

Print name(s) of person(s) signing

State nature of authority if applicable

This offer will lapse unless accepted within [] clear business days (3 clear business days if none specified).

SIGNED BY THE VENDOR

..... on/...../20__

JOSEPH ALLAN BOWDEN and SHARON GAYE BOWDEN

The **DAY OF SALE** is the date by which both parties have signed this contract.

IMPORTANT NOTICE TO PURCHASERS

Cooling-off period (Section 31 of the *Sale of Land Act 1962*)

You may end this contract within 3 clear business days of the day that you sign the contract if none of the exceptions listed below applies to you.

You must either give the vendor or the vendor's agent **written** notice that you are ending the contract or leave the notice at the address of the vendor or the vendor's agent to end this contract within this time in accordance with this cooling-off provision.

You are entitled to a refund of all the money you paid EXCEPT for \$100 or 0.2% of the purchase price (whichever is more) if you end the contract in this way.

EXCEPTIONS: The 3-day cooling-off period does not apply if-

- you bought the property at or within 3 clear business days **before or after** a publicly advertised auction; or
- the property is used primarily for industrial or commercial purposes; or
- the property is more than 20 hectares in size and is used primarily for farming; or
- you and the vendor have previously signed a contract for the sale of the same land in substantially the same terms; or
- you are an estate agent or a corporate body

*This contract is approved by the Law Institute of Victoria Limited, a professional association within the meaning of the **Legal Professional Act 2004**, under section 53A of the **Estate Agents Act 1980**.

NOTICE TO PURCHASERS OF PROPERTY OFF THE PLAN

Off-the-plan sales (Section 9AA(1A) of the *Sale of Land Act 1962*)

You may negotiate with the vendor about the amount of the deposit moneys payable under the contract of sale, up to 10 per cent of the purchase price.

A substantial period of time may elapse between the day on which you sign

the contract of sale and the day on which you become the registered proprietor of the lot.

The value of the lot may change between the day on which you sign the contract of sale of that lot and the day on which you become the registered proprietor.

PARTICULARS OF SALE

VENDOR'S ESTATE AGENT

Harcourts - Thomastown

1/337 Settlement Road, Thomastown VIC 3074

Tel: (03) 94657766

Fax: (03) 94643177

Mob: 0402 779 055

Email: sold@rataandco.com.au

VENDORS

Joseph Allan Bowden and Sharon Gaye Bowden

VENDOR'S LEGAL PRACTITIONER OR CONVEYANCER

Perfect Choice Conveyancing

820 Pascoe Vale Road, Glenroy VIC 3046

Ref: 17084 Nick Sahin

Tel: 9304-1070

Fax: 9304-1071

Email: info@pcconveyancing.com.au

PURCHASER

Name:

.....

Address:

PURCHASER'S LEGAL PRACTITIONER OR CONVEYANCER

Name:

Address:

Email:

Tel:

Mob:

Fax:

Ref:

LAND (general conditions 7 and 13)

The land is -

described in the table below-

| Certificate of Title reference | Being lot | On plan |
|--------------------------------|-----------|----------|
| Volume 8541 Folio 028 | 521 | LP033339 |
| Volume Folio | | |

OR

described in the copy of the Register Search Statement and the document or part document referred to as the diagram location in the Register Search Statement, as attached to the section 32 statement if no title or plan references are recorded in the table above or as described in the section 32 statement if the land is general law land.

The land includes all improvements and fixtures.

PROPERTY ADDRESS

The address of the land is: **13 Mulberry Parade, Heidelberg West VIC 3081**

GOODS SOLD WITH THE LAND (general condition 6.3(f)) (list or attach schedule)

All fixtures and fittings as inspected.

PAYMENT

Price \$

Deposit \$ _____ by _____ (of which \$ _____ has been paid)

Balance \$ _____ payable at settlement

GST (general condition 19)

The price includes GST (if any) unless the words 'plus GST' appear in this box

If this sale is a sale of land on which a 'farming business' is carried on which the parties consider meets requirements of section 38-48 of the **GST Act** or of a 'going concern' then add the words '**farming business**' or '**going concern**' in this box

If the margin scheme will be used to calculate GST then add the words '**margin scheme**' in this box

SETTLEMENT (general conditions 17 & 26.2)

is due on the _____ **day of** _____, **20**__

unless the land is a lot on an unregistered plan of subdivision, in which case settlement is due on the later of:

- the above date; or
- 14 days after the vendor gives notice in writing to the purchaser of registration of the plan of subdivision; or
- 7 days after the vendor gives notice in writing to the purchaser issue of the Occupancy Permit.

LEASE (general condition 5.1)

At settlement the purchaser is entitled to vacant possession of the property unless the words '**subject to lease**' appear in this box in which case refer to general condition 5.1.

If '**subject to lease**' then particulars of the lease are: Not Applicable.

(*only complete the one that applies. Check tenancy agreement/lease **before** completing details)

TERMS CONTRACT (general condition 30)

If this contract is intended to be a terms contract within the meaning of the *Sale of Land Act 1962* then add the words '**terms contract**' in this box and refer to general condition 30 and add any further provisions by way of special conditions.

LOAN (general condition 20)

The following details apply if this contract is subject to a loan being approved.

Lender:

Loan amount

Approval date:

BUILDING REPORT

General condition 21 applies only if the box is checked.

PEST REPORT

General condition 22 applies only if the box is checked.

This contract does not include any special conditions unless the words '**special conditions**' appear in this box

Special Conditions

SPECIAL CONDITIONS

Any Special Conditions written below which are inconsistent with the General Conditions hereinbefore contained shall modify or exclude such Conditions to the extent of such inconsistency.

INTERPRETATION

1. In this contract except where inconsistent with the context or subject matter words importing the singular shall include the plural words importing the plural shall include the singular words importing one gender shall include any other gender and if there is more than one purchaser then each purchaser shall be bound both severally and also jointly with every other purchaser by the terms and conditions of this contract to be performed and observed by the purchaser.

ACKNOWLEDGMENT OF STATEMENT

2. The purchaser hereby acknowledges that prior to signing this contract and prior to signing any other documents relating to the sale hereby effected he received a statement in writing signed by the Vendor pursuant to Section 32 of the Sale of Land Act 1962 (as amended) in the form included in this Contract of Sale.

REPRESENTATIONS

3. The Purchaser admits that this Contract constitutes the whole of the agreement made between the Vendor and the Purchaser. The Purchaser acknowledges that there are no conditions, obligations, representations, terms or warranties (except those contained herein) relating to the sale of the property, including any made by the Vendor or its agents unless these are set out in the Contract.

ACKNOWLEDGMENT AS TO INSPECTION OF PROPERTY

4. The purchaser acknowledges that the purchaser has inspected the property and Chattels in their present condition and state of repair and with any defects existing at the date thereof. The Purchaser agrees that the Vendor is under no liability or obligations to carry out repairs, renovations, alternations or improvements.

NOMINATION

5. If the contract states that the property is sold to a named purchaser "and/or nominee", the named purchaser may, at least fourteen (14) days prior to the settlement date, nominate an additional or substitute Purchaser, however the named purchaser remains personally liable for the due performance of all the Purchaser's obligations under this Contract of Sale.
 - a) If the nominated Purchaser is a company then the named Purchaser shall deliver the guarantee herewith, signed by all the directors of the company to the Vendor's conveyance.

VENDOR'S LOSS AND DAMAGE

6. The purchaser breaching this Contract shall pay upon all demand all expenses incurred by the Vendor as a result of such breach notwithstanding:
 - That the purchaser may not be aware at the date of the Contract of the particular consequences which may flow from delay in settlement; and
 - That such damages could not have reasonably been foreseen by the Purchaser.

The Vendor gives notice to the Purchaser that in the event that the Purchaser fails to complete the purchase of the property on the due date under the Contract or at a time subsequently arranged by consent with their representative, the Vendor will or may suffer the following losses and expenses which the Purchaser moneys in accordance with the terms of the Contract: -

- a) The cost of obtaining bridging finance to complete the Vendor's purchaser of another property and interest charged on such bridging finance calculated from the due date of the settlement.
- b) Interest payable by the Vendor under any existing Mortgage over the property calculated from settlement;
- c) Accommodation expenses necessarily incurred by the Vendor;

- d) A fee for rescheduling settlement on the day of settlement or after set at \$550.00 per re-attendance;
- e) Legal and Conveyancing, representatives costs and expenses as between Vendor's solicitor/Vendor's representative and Vendor;
- f) Penalties payable by the Vendor to a third party through any delay in completion of the Vendor's purchase of another property.

If the Vendor gives to the Purchaser a notice of default under this contract, the default will not be remedied until remedy by the purchaser of the relevant default or if the default is incapable of remedy, compensation is paid to the Vendor's satisfaction.

DEFAULT INTEREST

- 7. Should the Purchaser default in payment of any money due under this Contract, then interest at the rate of 14 per centum (14%) per annum shall be paid on demand by the Purchaser to the Vendor upon the money overdue. The said interest shall be computed from the due date herein provided for the payment of the said money until such monies are paid and shall be payable by the Purchaser to the Vendor upon demand without necessity for any notice in writing whether under General Condition 33 or otherwise. The exercise of the Vendor's rights hereunder shall be without prejudice to any other rights powers and remedies of the Vendor under this Contract or otherwise. The provisions of General Condition 33 shall not apply to this Contract.

MERGER

- 8. The provisions of this contract shall not merge in the transfer of the land and shall continue to bind the vendor and the purchaser to the extent that any of them require to be complied with after the Settlement Date.

SWIMMING POOL OR SPA

- 9. If the Property contains a swimming pool or spa the Building Regulations require suitable safety barriers to be established. The Purchaser acknowledges responsibility for this from the date of Contract and warrants to the Vendor it will comply with all building regulations and other requirements that may apply in relation to the swimming pool or spa.

NOTICES

- 10. The Purchaser will be responsible from the date of Contract for complying with any notice, order, declaration or report including payment of any new or special levy that may affect the Property.

The purchaser will indemnify and keep indemnified against all claims, demands, proceedings, judgments, damages, costs and losses of any nature whatsoever which the vendor may suffer, sustain or incur in connection with or relating to any liability, claim or action, demand, suit or proceedings howsoever arising, made or incurred on or subsequent to settlement, or from events or occurrences happening or arising on or subsequent to settlement, in any way in connection with the Property or any act, matter or thing occurring thereon.

FOREIGN ACQUISITIONS AND TAKEOVERS ACT 1975

- 11. The purchaser warrants to the vendor that any approval required under the Foreign Acquisition and Takeovers Act 1975 (as amended) or any real estate policy guidelines of the Commonwealth Government and/or the approval of The Reserve Bank of Australia under the banking (Foreign Exchange) Regulations to enter into this contract has been obtained or that a statement of non-objection in connection with the Foreign Acquisition and Takeovers act 1975 or such guidelines has been obtained. In the event that this warranty is untrue in any respect the purchaser hereby indemnifies and keeps indemnified the vendor against any loss (including consequential loss) which the vendor suffers as a result of the vendor having relied on this warranty at the time of entering into this contract.

Where the purchaser is not a resident and ordinary domiciled in Australia or a foreign company, the purchaser shall:-

- a) Within 60 days of request of the vendor produce to the vendor adequate proof of the Purchaser's ability to pay the residue of moneys owing in the form of
 - I. Written confirmation from an Australian bank showing funds on deposit being available for the settlement of the contract;
 - II. A letter of approval from an Australian bank in respect of any loan to be taken out by the purchaser for the settlement for the settlement of the contract;
 - III. Any other approval or confirmation approved by the vendor sufficient to show the ability of the purchaser to pay the residue owing.
- b) Any failure by the purchaser to comply with the provisions of this clause shall be deemed a material breach of this contract and the vendor shall be entitled to rescind this contract.

MULTIPLE PURCHASERS

12. If there is more than one purchase then:-

- a) The Purchasers obligations in this will bind all those persons jointly and severally;
- b) It is the purchaser's responsibility to ensure the contract correctly records at the date of sale the proportions in which they are buying the property.
- c) If the proportions recorded in the transfer differ from those recorded in the contract, it is the purchasers responsibility to pay any additional duty which may be assessed as a result of the variation;
- d) The purchasers fully indemnify the vendor, the vendor's agent and representative against any claims or demands which may be made against any or all of them in relation to any additional duty payable as a result of the proportions in the transfer differing from those in the contract.
- e) This special condition will not merge on completion.

EARLY POSSESSION

13. In the event that the Vendor allows the Purchaser to take possession of the subject property prior to the settlement then the Purchaser shall execute a licence agreement as prepared by the Vendor's representative and shall prior to taking possession pay the costs associated with the said preparation.

SUBJECT TO LEASE (if applicable)

14. If the property is being sold subject to a lease or receipt of their rents and profits.

The purchaser acknowledges being satisfied with all aspects of the lease and will not make any claim or objection in respect of the lease or any variation to it.

The rent and all outgoings payable by the tenant under the lease (the lease money) will be apportioned on the settlement date between the vendor and the purchaser as follows:

- a) The vendor will be entitled to all lease money payable in respect of the full period up to and including the settlement date and the purchaser will be entitled to all lease money payable from the date after that date.
- b) Where lease money has been paid to the vendor for a period expiring after the settlement date the vendor allow the purchaser a proportion that the number of days remaining in the period after settlement date bears to the total number of days in the period.
- c) If any lease moneys are in arrears the purchaser will allow those arrears to the vendor.

The purchaser agrees that after the settlement date the vendor will be entitled to commence proceedings in the name of the purchaser against the tenants under the lease to recover any rent which may be unpaid on the settlement date or to enforce the tenant's obligation to pay rates or other outgoings.

The purchaser must pay to the vendor any lease money received by the purchaser for any period up to the settlement date.

This condition will not merge on settlement but remain in operation for as long as is necessary to give effect to it.

PLAN OF SUBDIVISION (if applicable)

15. The Purchaser acknowledges that as at the Day of Sale the plan of Subdivision has not been registered by the Registrar of Titles pursuant to Part 4 of the Subdivision Act or Section 97 of the Transfer of Land Act (as the case may be).
- a) The vendor shall at his/her own cost and expense procure registration of the Plan of Subdivision.
 - b) If the Plan is not registered within (18) months after the Day of Sale, either the Purchaser or the Vendor may after the expiration of that (18) months but before the Plan of Subdivision is so registered rescind this Contract of Sale by notice in writing to the other party and the Deposit Money shall then be repaid to the Purchaser in full.
 - c) The Vendor reserves the right to make alternation to the Plan of Subdivision necessary to secure its approval by the Registrar of Titles and (subject to the provisions of Section 9AC of the Sale of Land) the purchaser shall make no objection or requisition or claim any compensation in respect of any excess or deficiency whether in areas, boundaries, measurements, occupation and otherwise on the ground that the Plan of Subdivision as registered by the Registrar of Titles does not agree in measurement or otherwise with the Plan of Subdivision or the property as inspected by the Purchaser.
 - d) Plans of Works intended to affect the natural surface levels of the land comprised in the Plan and the abutting land are annexed to the Section 32 Statement (if applicable). The Vendor reserves the right to alter the natural surface levels of the property any time after the Day of Sale. The Vendor Shall notify the Purchaser as soon as practicable of any changes to the works already disclosed in the Vendor's Section 32 Statement (if applicable).
 - e) Until such time as the Plan of Subdivision has been registered by the Registrar of Titles the Purchaser shall not lodge or cause permit to be lodged on the Purchaser's behalf any Caveat in respect of the Purchaser's interest in the property and the purchaser shall indemnify and keep indemnified the Vendor against any loss or damage which the Vendor may incur or suffer as a consequence of any breach by the Purchaser of this provision.

OWNER BUILDER (if applicable)

16. The Purchaser acknowledges that prior to signing the contract, the purchaser has received a copy of the inspection report as prescribed in Section 137B of the Building Act 1993, and a copy of a certificate evidencing the existence of the required insurance.

The Vendor warrants that they have effected a Policy Insurance which indemnifies the purchaser (and any subject purchasers) against all losses and damage during the period of insurance which result from:

- a) Any breach of the Statutory Warranties under Section 137C of the Act; and
- b) Alternative accommodation, removal and/or storage costs reasonably and necessarily incurred as a result of any event under (a) above.

The Vendor warrants that all domestic building work carried out in relation to the construction by or on behalf of the Vendor of the home was carried out in a proper and workmanlike manner.

The Vendor warrants that all materials used in that domestic building work were good and suitable for the purpose for which they were used and that, unless otherwise stated in the contract, those materials were new.

The Vendor warrants that domestic building work has carried out in accordance with all laws and legal requirements, including, without limiting the generality of this warranty, the Act and the regulations.

RATE CERTIFICATES

17. The Purchaser agrees to provide copies of all certificates issued within 60 days prior to settlement obtained by them to complete any adjustments to the Vendor's Representative if requested. The certificates must be in PDF format, not redacted in any way and must not be password protected. The Vendor will not be obliged to provide cheque details until this condition has been complied with.

STATEMENT OF ADJUSTMENTS

18. Further to General Condition 23, Adjustments must be prepared on behalf of the Purchaser and provided to Perfect Choice Conveyancing Services not less than 5 business days prior to the due date of settlement and any failure to do so, will cause the Purchaser to pay an administration fee to Perfect Choice Conveyancing of \$330.00 for the delay in receiving the Statement of Adjustments.
19. The provisions of this Contract shall apply and prevail over any statutory or implied conditions but only to the extent of any inconsistency and to the extent permissible at law.

AUCTION CONDITIONS (if applicable)

20. The property is offered for sale by public auction, subject to the vendor's reserve price. The Rules for the conduct of the auction shall be as set in the Sale of Land (Public Auctions) Regulations 2014 or any rules prescribed by regulation which modify or replace those Rules.

DEPOSIT RELEASE

21. The purchaser agrees to release the deposit monies to the vendor via signed Section 27 Statement along with a copy of the Section 27 letter from the mortgagee (if applicable). The purchaser will not object to the release of deposit monies.

SUBJECT TO FINANCE

22. In the event that the contract of sale is subject to finance and the Purchaser's finance has not been approved by the due date, the Purchaser must:
 - (a) provide a declined letter from the lender (not the mortgage broker) stipulated on the Contract of Sale to confirm that the finance has been declined; and
 - (b) provide sufficient evidence and the circumstances as to why the finance was declined.

Should the declined letter and sufficient information not be provided in writing to our office, the Vendor will not instruct the selling agent or stakeholder to refund any deposit monies to the Purchaser until this is satisfied by the Vendor.

SETTLEMENT AGENT APPOINTMENT

23. The purchaser acknowledges that the Vendor has appointed Perfect Choice Conveyancing Services as its agent for the purpose of completing this transaction and for directing the payment of all moneys payable pursuant to the Contract. The purchaser and their representative acknowledge that they will not be entitled to request any further proof of this authority.

General Conditions

Contract Signing

1. ELECTRONIC SIGNATURE

- 1.1 In this general condition "electronic signature" means a digital signature or a visual representation of a person's handwritten signature or mark which is placed on a physical or electronic copy of this contract by electronic or mechanical means, and "electronically signed" has a corresponding meaning.
- 1.2 The parties' consent to this contract being signed by or on behalf of a party by an electronic signature.
- 1.3 Where this contract is electronically signed by or on behalf of a party, the party warrants and agrees that the electronic signature has been used to identify the person signing and to indicate that the party intends to be bound by the electronic signature.
- 1.4 This contract may be electronically signed in any number of counterparts which together will constitute the one document.
- 1.5 Each party consents to the exchange of counterparts of this contract by delivery by email or such other electronic means as may be agreed in writing.
- 1.6 Each party must upon request promptly deliver a physical counterpart of this contract with the handwritten signature or signatures of the party and all written evidence of the authority of a person signing on their behalf, but a failure to comply with the request does not affect the validity of this contract.

2. LIABILITY OF SIGNATORY

Any signatory for a proprietary limited company purchaser is personally liable for the due performance of the purchaser's obligations as if the signatory were the purchaser in the case of a default by a proprietary limited company purchaser.

3. GUARANTEE

The vendor may require one or more directors of the purchaser to guarantee the purchaser's performance of this contract if the purchaser is a proprietary limited company.

4. NOMINEE

The purchaser may no later than 14 days before the due date for settlement nominate a substitute or additional person to take a transfer of the land, but the named purchaser remains personally liable for the due performance of all the purchaser's obligations under this contract.

Title

5. ENCUMBRANCES

- 5.1 The purchaser buys the property subject to:
 - (a) any encumbrance shown in the section 32 statement other than mortgages or caveats; and
 - (b) any reservations, exceptions and conditions in the crown grant; and
 - (c) any lease or tenancy referred to in the particulars of sale.
- 5.2 The purchaser indemnifies the vendor against all obligations under any lease or tenancy that are to be performed by the landlord after settlement.

6. VENDOR WARRANTIES

- 6.1 The vendor warrants that these general conditions 1 to 35 are identical to the general conditions 1 to 35 in the form of contract of sale of land published by the Law Institute of Victoria Limited and the Real Estate Institute of Victoria Ltd in the month and year set out at the foot of this page.
- 6.2 The warranties in general conditions 6.3 and 6.4 replace the purchaser's right to make requisitions and inquiries.
- 6.3 The vendor warrants that the vendor:
 - (a) has, or by the due date for settlement will have, the right to sell the land; and
 - (b) is under no legal disability; and
 - (c) is in possession of the land, either personally or through a tenant; and
 - (d) has not previously sold or granted any option to purchase, agreed to a lease or granted a pre-emptive right which is current over the land and which gives another party rights which have priority over the interest of the purchaser; and
 - (e) will at settlement be the holder of an unencumbered estate in fee simple in the land; and
 - (f) will at settlement be the unencumbered owner of any improvements, fixtures, fittings and goods sold with the land.
- 6.4 The vendor further warrants that the vendor has no knowledge of any of the following:
 - (a) public rights of way over the land;
 - (b) easements over the land;
 - (c) lease or other possessory agreement affecting the land;
 - (d) notice or order directly and currently affecting the land which will not be dealt with at settlement, other than the usual rate notices and any land tax notices;
 - (e) legal proceedings which would render the sale of the land void or voidable or capable of being set aside.

- 6.5 The warranties in general conditions 6.3 to 6.4 are subject to any contrary provisions in this contract and disclosures in the section 32 statement.
- 6.6 If sections 137B and 137C of the *Building Act 1993* apply to this contract, the vendor warrants that:
- (a) all domestic building work carried out in relation to the construction by or on behalf of the vendor of the home was carried out in a proper and workmanlike manner; and
 - (b) all materials used in that domestic building work were good and suitable for the purpose for which they were used and that, unless otherwise stated in the contract, those materials were new; and
 - (c) domestic building work was carried out in accordance with all laws and legal requirements, including, without limiting the generality of this warranty, the *Building Act 1993* and regulations made under the *Building Act 1993*.
- 6.7 Words and phrases used in general condition 6.6 which are defined in the *Building Act 1993* have the same meaning in general condition 6.6.

7. IDENTITY OF THE LAND

- 7.1 An omission or mistake in the description of the property or any deficiency in the area, description or measurements of the land does not invalidate the sale.
- 7.2 The purchaser may not:
- (a) make any objection or claim for compensation for any alleged misdescription of the property or any deficiency in its area or measurements; or
 - (b) require the vendor to amend title or pay any cost of amending title.

8. SERVICES

- 8.1 The vendor does not represent that the services are adequate for the purchaser's proposed use of the property and the vendor advises the purchaser to make appropriate inquiries. The condition of the services may change between the day of sale and settlement and the vendor does not promise that the services will be in the same condition at settlement as they were on the day of sale.
- 8.2 The purchaser is responsible for the connection of all services to the property after settlement and the payment of any associated cost.

9. CONSENTS

The vendor must obtain any necessary consent or licence required for the vendor to sell the property. The contract will be at an end and all money paid must be refunded if any necessary consent or licence is not obtained by settlement.

10. TRANSFER & DUTY

- 10.1 The purchaser must prepare and deliver to the vendor at least 7 days before the due date for settlement any paper transfer of land document which is necessary for this transaction. The delivery of the transfer of land document is not acceptance of title.
- 10.2 The vendor must promptly initiate the Duties Online or other form required by the State Revenue Office in respect of this transaction, and both parties must co-operate to complete it as soon as practicable.

11. RELEASE OF SECURITY INTEREST

- 11.1 This general condition applies if any part of the property is subject to a security interest to which the *Personal Property Securities Act 2009* (Cth) applies.
- 11.2 For the purposes of enabling the purchaser to search the Personal Property Securities Register for any security interests affecting any personal property for which the purchaser may be entitled to a release, statement, approval or correction in accordance with general condition 11.4, the purchaser may request the vendor to provide the vendor's date of birth to the purchaser. The vendor must comply with a request made by the purchaser under this condition if the purchaser makes the request at least 21 days before the due date for settlement.
- 11.3 If the purchaser is given the details of the vendor's date of birth under general condition 11.2, the purchaser must:
- (a) only use the vendor's date of birth for the purposes specified in general condition 11.2; and
 - (b) keep the date of birth of the vendor secure and confidential
- 11.4 The vendor must ensure that at or before settlement, the purchaser receives –
- (a) a release from the secured party releasing the property from the security interest; or
 - (b) a statement in writing in accordance with section 275(1)(b) of the *Personal Property Securities Act 2009* (Cth) setting out that the amount or obligation that is secured is nil at settlement; or
 - (c) a written approval or correction in accordance with section 275(1)(c) of the *Personal Property Securities Act 2009* (Cth) indicating that, on settlement, the personal property included in the contract is not or will not be property in which the security interest is granted.
- 11.5 Subject to general condition 11.6, the vendor is not obliged to ensure that the purchaser receives a release, statement, approval or correct in respect of personal property –
- (a) that –
 - (i) the purchaser intends to use predominantly for personal, domestic or household purposes; and

- (ii) has a market value of not more than \$5000 or, if a greater amount has been prescribed for the purposes of section 47(1) of the *Personal Property Securities Act 2009* (Cth), not more than that prescribed amount; or
 - (b) that is sold in the ordinary course of the vendor's business of selling personal property of that kind.
- 11.6 The vendor is obliged to ensure that the purchaser receives a release, statement, approval or correction in respect of personal property described in general condition 11.5 if –
 - (a) the personal property is of a kind that may or must be described by serial number in the Personal Property Securities Register; or
 - (b) the purchaser has actual or constructive knowledge that the sale constitutes a breach of the security agreement that provides for the security interest.
- 11.7 A release for the purposes of general condition 11.4(a) must be in writing.
- 11.8 A release for the purposes of general condition 11.4(a) must be effective in releasing the goods from the security interest and be in a form which allows the purchaser to take title to the goods free of that security interest.
- 11.9 If the purchaser receives a release under general condition 11.4(a) the purchaser must provide the vendor with a copy of the release at or as soon as practicable after settlement.
- 11.10 In addition to ensuring that a release is received under general condition 11.4(a), the vendor must ensure that at or before settlement the purchaser receives a written undertaking from a secured party to register a financing change statement to reflect that release if the property being released includes goods of a kind that are described by serial number in the Personal Property Securities Register.
- 11.11 The purchaser must advise the vendor of any security interest that is registered on or before the day of sale on the Personal Property Securities Register, which the purchaser reasonably requires to be released, at least 21 days before the due date for settlement.
- 11.12 The vendor may delay settlement until 21 days after the purchaser advises the vendor of the security interests that the purchaser reasonably requires to be released if the purchaser does not provide an advice under general condition 11.11.
- 11.13 If settlement is delayed under general condition 11.12 the purchaser must pay the vendor –
 - (a) interest from the due date for settlement until the date on which settlement occurs or 21 days after the vendor receives the advice, whichever is the earlier; and
 - (b) any reasonable costs incurred by the vendor as a result of the delay –
as though the purchaser was in default.
- 11.14 The vendor is not required to ensure that the purchaser receives a release in respect of the land. This general condition 11.14 applies despite general condition 11.1
- 11.15 Words and phrases which are defined in the *Personal Property Securities Act 2009* (Cth) have the same meaning in general condition 11 unless the context requires otherwise.

12. BUILDER WARRANTY INSURANCE

The vendor warrants that the vendor will provide at settlement details of any current builder warranty insurance in the vendor's possession relating to the property if requested in writing to do so at least 21 days before settlement.

13. GENERAL LAW LAND

- 13.1 The vendor must complete a conversion of title in accordance with section 14 of the *Transfer of Land Act 1958* before settlement if the land is the subject of a provision folio under section 23 of the Act.
- 13.2 The remaining provisions of this general condition 13 only apply if any part of the land is not under the operation of the *Transfer of Land Act 1958*.
- 13.3 The vendor is taken to be the holder of an unencumbered estate in fee simple in the land if there is an unbroken chain of title starting at least 30 years before the day of sale proving on the face of the documents the ownership of the entire legal and equitable estate without the aid of other evidence.
- 13.4 The purchaser is entitled to inspect the vendor's chain of title on request at such place in Victoria as the vendor nominates.
- 13.5 The purchaser is taken to have accepted the vendor's title if :
 - (a) 21 days have elapsed since the day of sale; and
 - (b) the purchaser has not reasonably objected to the title or reasonably required the vendor to remedy a defect in the title.
- 13.6 The contract will be at an end if:
 - (a) the vendor gives the purchaser a notice that the vendor is unable or unwilling to satisfy the purchaser's objection or requirement and that the contract will end if the objection or requirement is not withdrawn within 14 days of the giving of the notice; and
 - (b) the objection or requirement is not withdrawn in that time.
- 13.7 If the contract ends in accordance with general condition 13.6, the deposit must be returned to the purchaser and neither party has a claim against the other in damages.
- 13.8 General condition 17.1 [settlement] should be read as if the reference to 'registered proprietor' is a refer to 'owner' in respect of that part of the land which is not under the operation of the *Transfer of Land Act 1958*.

Money

14. DEPOSIT

14.1 The purchaser must pay the deposit:

- (a) to the vendor's licensed estate agent; or
- (b) if there is no estate agent, to the vendor's legal practitioner or conveyancer; or
- (c) if the vendor directs, into a special purpose account in an authorised deposit-taking institution in Victoria specified by the vendor in the joint names of the purchaser and the vendor.

14.2 If the land sold is a lot on an unregistered plan of subdivision, the deposit:

- (a) must not exceed 10% of the price; and
- (b) must be paid to the vendor's estate agent, legal practitioner or conveyancer and held by the estate agent, legal practitioner or conveyancer on trust for the purchaser until the registration of the plan of subdivision.

14.3 The deposit must be released to the vendor if:

- (a) the vendor provides particulars, to the satisfaction of the purchaser, that either –
 - (i) there are no debts secured against the property; or
 - (ii) if there are any debts, the total amount of those debts together with any amounts to be withheld in accordance with general conditions 24 and 25 does not exceed 80% of the sale price; and
- (b) at least 28 days have elapsed since the particulars were given to the purchaser under paragraph (a); and
- (c) all conditions of section 27 of the *Sale of Land Act 1962* have been satisfied.

14.4 The stakeholder must pay the deposit and any interest to the party entitled when the deposit is released, the contract is settled, or the contract is ended.

14.5 The stakeholder may pay the deposit and any interest into court if it is reasonable to do so.

14.6 Where the purchaser is deemed by section 27(7) of the *Sale of Land Act 1962* to have given the deposit release authorisation referred to in section 27(1), the purchaser is also deemed to have accepted title in the absence of any prior express objection to the title.

14.7 Payment of the deposit may be made or tendered:

- (a) in cash up to \$1,000 or 0.2% of the price, whichever is greater; or
- (b) by cheque drawn on an authorised deposit-taking institution; or
- (c) by electronic funds transfer to a recipient having the appropriate facilities for receipt.

However, unless otherwise agreed:

- (d) payment may not be made by credit card, debit card or any other financial transfer system that allows for any chargeback or funds reversal other than for fraud or mistaken payment, and
- (e) any financial transfer or similar fees or deductions from the funds transferred, other than any fees charged by the recipient's authorised deposit-taking institution, must be paid by the remitter.

14.8 Payment by electronic funds transfer is made when cleared funds are received in the recipient's bank account.

14.9 Before the funds are electronically transferred the intended recipient must be notified in writing and given sufficient particulars to readily identify the relevant transaction.

14.10 As soon as the funds have been electronically transferred the intended recipient must be provided with the relevant transaction number or reference details.

14.11 For the purpose of this general condition 'authorised deposit-taking institution' means a body corporate for which an authority under section 9(3) of the *Banking Act 1959* (Cth) is in force.

15. DEPOSIT BOND

15.1 This general condition only applies if the applicable box in the particulars of sale is checked.

15.2 In this general condition "deposit bond" means an irrevocable undertaking to pay on demand an amount equal to the deposit or any unpaid part of the deposit. The issuer and the form of the deposit bond must be satisfactory to the vendor. The deposit bond must have an expiry date at least 45 days after the due date for settlement.

15.3 The purchaser may deliver a deposit bond to the vendor's estate agent, legal practitioner or conveyancer within 7 days after the day of sale.

15.4 The purchaser may at least 45 days before a current deposit bond expires deliver a replacement deposit bond on the same terms and conditions.

15.5 Where deposit bond is delivered, the purchaser must pay the deposit to the vendor's legal practitioner or conveyancer on the first to occur of:

- (a) settlement;
- (b) the date that is 45 days before the deposit bond or any replacement deposit bond expires;
- (c) the date on which this contract ends in accordance with general condition 35.2 [default not remedied] following breach by the purchaser; and

- (d) the date on which the vendor ends this contract by accepting repudiation of it by the purchaser.
- 15.6 The vendor may claim on the deposit bond without prior notice if the purchaser defaults under this contract or repudiates this contract and the contract is ended. The amount paid by the issuer satisfies the obligations of the purchaser under general condition 15.5 to the extent of the payment.
- 15.7 Nothing in this general condition limits the rights of the vendor if the purchaser defaults under this contract or repudiates this contract, except as provided in general condition 15.6
- 15.8 This general condition is subject to general condition 14.2 [deposit].

16. BANK GUARANTEE

- 16.1 This general condition only applies if the applicable box in the particulars of sale is checked.
- 16.2 In this general condition:
 - (a) "bank guarantee" means an unconditional and irrevocable guarantee or undertaking by a bank in a form satisfactory to the vendor to pay on demand any amount under this contract agreed in writing, and
 - (b) "bank" means an authorised deposit-taking institution under the *Banking Act 1959* (Cth).
- 16.3 The purchaser may deliver a bank guarantee to the vendor's legal practitioner or conveyancer.
- 16.4 The purchaser must pay the amount secured by the bank guarantee to the vendor's legal practitioner or conveyancer on the first to occur of:
 - (a) settlement;
 - (b) the date that is 45 days before the bank guarantee expires;
 - (c) the date on which this contract ends in accordance with general condition 35.2 [default not remedied] following breach by the purchaser; and
 - (d) the date on which the vendor ends this contract by accepting repudiation of it by the purchaser.
- 16.5 The vendor must return the bank guarantee document to the purchaser when the purchaser pays the amount secured by the bank guarantee in accordance with general condition 16.4.
- 16.6 The vendor may claim on the bank guarantee without prior notice if the purchaser defaults under this contract or repudiates this contract and the contract is ended. The amount paid by the bank satisfies the obligations of the purchaser under general condition 16.4 to the extent of the payment.
- 16.7 Nothing in this general condition limits the rights of the vendor if the purchaser defaults under this contract or repudiates this contract except as provided in general condition 16.6.
- 16.8 This general condition is subject to general condition 14.2 [deposit].

17. SETTLEMENT

- 17.1 At settlement:
 - (a) the purchaser must pay the balance; and
 - (b) the vendor must:
 - (i) do all things necessary to enable the purchaser to become the registered proprietor of the land; and
 - (ii) give either vacant possession or receipt of rents and profits in accordance with the particulars of sale.
- 17.2 Settlement must be conducted between the hours of 10.00am and 4.00pm unless the parties agree otherwise.
- 17.3 The purchaser must pay all money other than the deposit in accordance with a written direction of the vendor or the vendor's legal practitioner or conveyancer.

18. ELECTRONIC SETTLEMENT

- 18.1 Settlement and lodgement of the instruments necessary to record the purchaser as registered proprietor of the land will be conducted electronically in accordance with the Electronic Conveyancing National Law. This general condition 18 has priority over any other provision of this contract to the extent of any inconsistency.
- 18.2 A party must immediately give written notice if that party reasonably believes that settlement and lodgement can no longer be conducted electronically. General condition 18 ceases to apply from when such a notice is given.
- 18.3 Each party must:
 - (a) be, or engage a representative who is, a subscriber for the purposes of the Electronic Conveyancing National Law,
 - (b) ensure that all other persons for whom that party is responsible and who are associated with this transaction are, or engage, a subscriber for the purposes of the Electronic Conveyancing National Law, and
 - (c) conduct the transaction in accordance with the Electronic Conveyancing National Law.
- 18.4 The vendor must open the electronic workspace ("workspace") as soon as reasonably practicable and nominate a date and time for settlement. The inclusion of a specific date and time for settlement in a workspace is not of itself a promise to settle on that date or at that time. The workspace is an electronic address for the service of notices and for written communications for the purposes of any electronic transactions legislation.
- 18.5 This general condition 18.5 applies if there is more than one electronic lodgement network operator in respect of the transaction. In this general condition 18.5 "the transaction" means this sale and purchase and any associated transaction involving any of the same subscribers.

To the extent that any interoperability rules governing the relationship between electronic lodgement network operators do not provide otherwise:

- (a) the electronic lodgement network operator to conduct all the financial and lodgement aspects of the transaction after the workspace locks must be one which is willing and able to conduct such aspects of the transaction in accordance with the instructions of all the subscribers in the workspaces of all the electronic lodgement network operators after the workspace locks.
- (b) if two or more electronic lodgement network operators meet that description, one may be selected by purchaser's incoming mortgagee having the highest priority but if there is no mortgagee of the purchaser, the vendor must make the selection.

18.6 Settlement occurs when the workspace records that:

- (a) there has been an exchange of funds or value between the exchange settlement account or accounts in the Reserve Bank of Australia of the relevant financial institutions or their financial settlement agents in accordance with the instructions of the parties; or
- (b) if there is no exchange of funds or value, the documents necessary to enable the purchaser to become registered proprietor of the land have been accepted for electronic lodgement.

18.7 The parties must do everything reasonably necessary to effect settlement:

- (a) electronically on the next business day, or
- (b) at the option of either party, otherwise than electronically as soon as possible –

if, after the locking of the workspace at the nominated settlement time, settlement in accordance with general condition 18.6 has not occurred by 4.00pm, or 6.00pm if the nominated time for settlement is after 4.00pm.

18.8 Each party must do everything reasonably necessary to assist the other party to trace and identify the recipient of any missing or mistaken payment and to recover the missing or mistaken payment.

18.9 The vendor must before settlement:

- (a) deliver any keys, security devices and codes ("keys") to the estate agent named in the contract,
- (b) direct the estate agent to give keys to the purchaser or the purchaser's nominee on notification of settlement by the vendor, the vendor's subscriber or the electronic lodgement network operator;
- (c) deliver all other physical documents and items (other than the goods sold by the contract) to which the purchaser is entitled at settlement, and any keys if not delivered to the estate agent, to the vendor's subscriber or, if there is no vendor's subscriber, confirm in writing to the purchaser that the vendor holds those documents, items and keys at the vendor's address set out in the contract, and

give, or direct its subscriber to give, all those documents and items and any such keys to the purchaser or the purchaser's nominee on notification by the electronic lodgement network operator of settlement.

19. GST

19.1 The purchaser does not have to pay the vendor any amount in respect of GST in addition to the price if the particulars of sale specify that the price includes GST (if any).

19.2 The purchaser must pay to the vendor any GST payable by the vendor in respect of a taxable supply made under this contract in addition to the price if :

- (a) the particulars of sale specify that GST (if any) must be paid in addition to the price; or
- (b) GST is payable solely as a result of any action taken or intended to be taken by the purchaser after the day of sale, including a change of use; or
- (c) the particulars of sale specify that the supply made under this contract is of land on which a 'farming business' is carried on and the supply (or part of it) does not satisfy the requirements of section 38-480 of the GST Act; or
- (d) the particulars of sale specify that the supply made under this contract is of a going concern and the supply (or a part of it) does not satisfy the requirements of section 38-325 of the GST Act.

19.3 The purchaser is not obliged to pay any GST under this contract until a tax invoice has been given to the purchaser, unless the margin scheme applies.

19.4 If the particulars of sale specify that the supply made under this contract is of land on which a 'farming business' is carried on:

- (a) the vendor warrants that the property is land on which a farming business has been carried on for the period of 5 years preceding the date of supply; and
- (b) the purchaser warrants that the purchaser intends that a farming business will be carried on after settlement on the property.

19.5 If the particulars of sale specify that the supply made under this contract is a 'going concern':

- (a) the parties agree that this contract is for the supply of a going concern; and
- (b) the purchaser warrants that the purchaser is, or prior to settlement will be, registered for GST; and
- (c) the vendor warrants that the vendor will carry on the going concern until the date of supply.

19.6 If the particulars of sale specify that the supply made under this contract is a 'margin scheme' supply, the parties agree that the margin scheme applies to this contract.

19.7 In this general condition:

- (a) 'GST Act' means *A New Tax System (Goods and Services Tax) Act 1999* (Cth); and
- (b) 'GST' includes penalties and interest.

20. LOAN

20.1 If the particulars of sale specify that this contract is subject to a loan being approved, this contract is subject to the lender approving the loan on the security of the property by the approval date or any later date allowed by the vendor.

20.2 The purchaser may end the contract if the loan is not approved by the approval date, but only if the purchaser:

- (a) immediately applied for the loan; and
- (b) did everything reasonably required to obtain approval of the loan; and
- (c) serves written notice ending the contract, together with written evidence of rejection or non-approval of the loan, on the vendor within 2 clear business days after the approval date or any later date allowed by the vendor; and
- (d) is not in default under any other condition of this contract when the notice is given.

20.3 All money must be immediately refunded to the purchaser if the contract is ended.

21. BUILDING REPORT

21.1 This general condition only applies if the applicable box in the particulars of sale is checked.

21.2 The purchaser may end this contract within 14 days from the day of sale if the purchaser:

- (a) obtains a written report from a registered building practitioner or architect which discloses a current defect in a Structure on the land and designates it as a major building defect;
- (b) gives the vendor a copy of the report and a written notice ending this contract; and
- (c) is not then in default.

21.3 All money paid must be immediately refunded to the purchaser if the contract ends in accordance with this general condition.

21.4 A notice under this general condition may be served on the vendor's legal practitioner, conveyancer or estate agent even if the estate agent's authority has formally expired at the time of service.

21.5 The registered building practitioner may inspect the property at any reasonable time for the purpose of preparing the report.

22. PEST REPORT

22.1 This general condition only applies if the applicable box in the particulars of sale is checked.

22.2 The purchaser may end this contract within 14 days from the day of sale if the purchaser:

- (a) obtains a written report from a pest control operator licensed under Victorian law which discloses a current pest infestation on the land and designates it as a major infestation affecting the structure of a building on the land;
- (b) gives the vendor a copy of the report and a written notice ending this contract; and
- (c) is not then in default.

22.3 All money paid must be immediately refunded to the purchaser if the contract ends in accordance with this general condition.

22.4 A notice under this general condition may be served on the vendor's legal practitioner, conveyancer or estate agent even if the estate agent's authority has formally expired at the time of service.

22.5 The pest control operator may inspect the property at any reasonable time for the purpose of preparing the report.

23. ADJUSTMENTS

23.1 The periodic outgoings payable by the vendor, and any rent and other income received in respect of the property must be apportioned between the parties on the settlement date and any adjustments paid and received as appropriate.

23.2 The period outgoings and rent and other income must be apportioned on the following basis:

- (a) the vendor is liable for the periodic outgoings and entitled to the rent and other income up to and including the day of settlement; and
- (b) the land is treated as the only land of which the vendor is owner (as defined in the *Land Tax Act 2005*); and
- (c) the vendor is taken to own the land as a resident Australian beneficial owner; and
- (d) any personal statutory benefit available to each party is disregarded in calculating apportionment.

23.3 The purchaser must provide all copies of all certificates and other information used to calculate the adjustments under general condition 23, if requested by the vendor.

24. FOREIGN RESIDENT CAPITAL GAINS WITHHOLDING

24.1 Words defined or used in Subdivision 14-D of Schedule 1 to the *Taxation Administration Act 1953* (Cth) have the same meaning in this general condition unless the context requires otherwise.

24.2 Every vendor under this contract is a foreign resident for the purposes of this general condition unless the vendor gives the purchaser a clearance certificate issued by the Commissioner under section 14-220 (1) of Schedule 1 to the *Taxation Administration Act 1953* (Cth). The specified period in the clearance certificate must include the actual date of settlement.

24.3 The remaining provisions of this general condition 24 only apply if the purchaser is required to pay the Commissioner an amount

in accordance with section 14-200(3) or section 14-235 of Schedule 1 to the *Taxation Administration Act 1953* (Cth) ("the amount") because one or more of the vendors is a foreign resident, the property has or will have a market value not less than the amount set out in section 14-215 of the legislation just after the transaction, and the transaction is not excluded under section 14-215(1) of the legislation.

- 24.4 The amount is to be deducted from the vendor's entitlement to the contract consideration. The vendor must pay to the purchaser at settlement such part of the amount as is represented by non-monetary consideration.
- 24.5 The purchaser must:
- (a) engage a legal practitioner or conveyancer ("representative") to conduct all legal aspects of settlement, including the Performance of the purchaser's obligations under the legislation and this general condition; and
 - (b) ensure that the representative does so.
- 24.6 The terms of the representative's engagement are taken to include instructions to have regard to the vendor's interests and instructions that the representative must:
- (a) pay, or ensure payment of, the amount to the Commissioner in the manner required by the Commissioner and as soon as reasonably and practicably possible, from moneys under the control or direction of the representative in accordance with this general condition if the sale of the property settles;
 - (b) promptly provide the vendor with proof of payment; and
 - (c) otherwise comply, or ensure compliance, with this general condition;
- despite:
- (d) any contrary instructions, other than from both the purchaser and the vendor; and
 - (e) any other provision in this contract to the contrary.
- 24.7 The representative is taken to have complied with the requirements of general condition 24.6 if:
- (a) the settlement is conducted through an electronic lodgement network; and
 - (b) the amount is included in the settlement statement requiring payment to the Commissioner in respect of this transaction.
- 24.8 Any clearance certificate or document evidencing variation to the amount in accordance with section 14-235(2) of Schedule 1 to the *Taxation Administration Act 1953* (Cth) must be given to the purchaser at least 5 business days before the due date for settlement.
- 24.9 The vendor must provide the purchaser with such information as the purchaser requires to comply with the purchaser's obligation to pay the amount in accordance with section 14-200 of Schedule 1 to the *Taxation Administration Act 1953* (Cth). The information must be provided within 5 business days of request by the purchaser. The vendor warrants that the information the vendor provides is true and correct.
- 24.10 The purchaser is responsible for any penalties or interest payable to the Commissioner on account of late payment of the amount.

25. GST WITHHOLDING

- 25.1 Words and expressions defined or used in Subdivision 14-E of Schedule 1 to the *Taxation Administration Act 1953* (Cth) or in *A New Tax System (Goods and Services Tax) Act 1999* (Cth) have the same meaning in this general condition unless the context requires otherwise. Words and expressions first used in this general condition and shown in italics and marked with an asterisk are defined or described in at least one of those Acts.
- 25.2 The purchaser must notify the vendor in writing of the name of the recipient of the *supply for the purposes of section 14-255 of Schedule 1 to the *Taxation Administration Act 1953* (Cth) at least 21 days before the due date for settlement unless the recipient is the purchaser named in the contract.
- 25.3 The vendor must at least 14 days before the due date for settlement provide the purchaser and any person nominated by the purchaser under general condition 4 with a GST withholding notice in accordance with section 14-255 of Schedule 1 to the *Taxation Administration Act 1953* (Cth), and must provide all information required by the purchaser or any person so nominated to confirm the accuracy of the notice.
- 25.4 The remaining provisions of this general condition 25 apply if the purchaser is or may be required to pay the Commissioner an *amount in accordance with section 14-250 of Schedule 1 to the *Taxation Administration Act 1953* (Cth) because the property is *new residential premises or *potential residential land in either case falling within the parameters of that section, and also if the sale attracts the operation of section 14-255 of the legislation. Nothing in this general condition 25 is to be taken as relieving the vendor from compliance with section 14-255.
- 25.5 The amount is to be deducted from the vendor's entitlement to the contract *consideration and is then taken to be paid to the vendor, whether or not the vendor provides the purchaser with a GST withholding notice in accordance with section 14-255 of Schedule 1 to the *Taxation Administration Act 1953* (Cth). The vendor must pay to the purchaser at settlement such part of the amount as is represented by non-monetary consideration.
- 25.6 The purchaser must:
- (a) engage a legal practitioner or conveyancer ("representative") to conduct all the legal aspects of settlement, including the performance of the purchaser's obligations under the legislation and this general condition; and
 - (b) ensure that the representative does so.
- 25.7 The terms of the representative's engagement are taken to include instructions to have regard to the vendor's interests relating to the payment of the amount to the Commissioner and instructions that representative must:
- (a) pay, or ensure payment of, the amount to the Commissioner in the manner required by the Commissioner and as

soon as reasonably and practicably possible, from moneys under the control or direction of the representative in accordance with this general condition on settlement of the sale of the property;

- (b) promptly provide the vendor with evidence of payment, including any notification or other document provided by the purchaser to the Commissioner relating to payment; and
- (c) otherwise comply, or ensure compliance, with this general condition;

despite:

- (d) any contrary instructions, other than from both the purchaser and the vendor; and
- (e) any other provision in this contract to the contrary.

25.8 The representative is taken to have complied with the requirements of general condition 25.7 if:

- (a) settlement is conducted through an electronic lodgement network; and
- (b) the amount is included in the settlement adjustment requiring payment to the Commissioner in respect of this transaction.

25.9 The purchaser may at settlement give the vendor a bank cheque for the amount in accordance with section 16-30 (3) of Schedule 1 to the *Taxation Administration Act 1953* (Cth), but only if:

- (a) so agreed by the vendor in writing; and
- (b) the settlement is not conducted through an electronic lodgement network.

However, if the purchaser gives the bank cheque in accordance with this general condition 25.9, the vendor must:

- (c) immediately after settlement provide the bank cheque to the Commissioner to pay the amount in relation to the supply; and
- (d) give the purchaser a receipt for the bank cheque which identifies the transaction and includes particulars of the bank cheque, at the same time the purchaser gives the vendor the bank cheque.

25.10 A party must provide the other party with such information as the other party requires to:

- (a) decide if an amount is required to be paid or the quantum of it, or
- (b) comply with the purchaser's obligation to pay the amount,

in accordance with section 14-250 of Schedule 1 to the *Taxation Administration Act 1953* (Cth). The information must be provided within 5 business days of a written request. The party providing the information warrants that it is true and correct.

25.11 The vendor warrants that:

- (a) at settlement, the property is not new residential premises or potential residential land in either case falling within the parameters of section 14-250 of Schedule 1 to the *Taxation Administration Act 1953* (Cth) if the vendor gives the purchaser a written notice under section 14-255 to the effect that the purchaser will not be required to make a payment under section 14-250 in respect of the supply, or fails to give a written notice as required by and within the time specified in section 14-255; and
- (b) the amount described in a written notice given by the vendor to the purchaser under section 14-255 of Schedule 1 to the *Taxation Administration Act 1953* (Cth) is the correct amount required to be paid under section 14-250 of the legislation.

25.12 The purchaser is responsible for any penalties or interest payable to the Commissioner on account of non-payment or late payment of the amount, except to the extent that:

- (a) the penalties or interest arise from any failure on the part of the vendor, including breach of a warranty in general condition 25.11; or
- (b) the purchaser has a reasonable belief that the property is neither new residential nor potential residential land requiring the purchaser to pay an amount to the Commissioner in accordance with section 14-250 (1) of Schedule 1 to the *Taxation Administration Act 1953* (Cth).

The vendor is responsible for any penalties or interest payable to the Commissioner on account of non-payment or late payment of the amount if either exception applies.

Transactional

26. TIME & CO OPERATION

26.1 Time is of the essence of this contract.

26.2 Time is extended until the next business day if the time for performing any action falls on a day which is not a business day.

26.3 Each party must do all things reasonably necessary to enable this contract to proceed to settlement, and must act in a prompt and efficient manner.

26.4 Any unfulfilled obligation will not merge on settlement.

27. SERVICE

27.1 Any document required to be served by or on any party may be served by or on the legal practitioner or conveyancer for that party.

27.2 A cooling off notice under section 31 of the *Sale of Land Act 1962* or a notice under general condition 20 [loan approval], 21 [building report] or 22 [pest report] may be served on the vendor's legal practitioner, conveyancer or estate agent even if the estate agent's authority has formally expired at the time of service.

27.3 A document is sufficiently served:

- (a) personally, or
- (b) by pre-paid post, or
- (c) in any manner authorised by law or by the Supreme Court for service of documents, including any manner authorised for service on or by a legal practitioner, whether or not the person serving or receiving the document is a legal practitioner, or
- (d) by email.

27.4 Any document properly sent by:

- (a) express post is taken to have been served on the next business day after posting, unless proved otherwise;
- (b) priority post is taken to have been served on the fourth business day after posting, unless proved otherwise;
- (c) regular post is taken to have been served on the sixth business day after posting, unless provide otherwise;
- (d) email is taken to have been served at the time of receipt within the meaning of section 13A of the *Electronic Transactions (Victoria) Act 2000*.

27.5 In this contract 'document' includes 'demand' and 'notice', 'serve' includes 'give', and 'served' and 'service' have corresponding meanings.

28. NOTICES

28.1 The vendor is responsible for any notice, order, demand or levy imposing liability on the property that is issued or made before the day of sale, and does not relate to periodic outgoings.

28.2 The purchaser is responsible for any notice, order, demand or levy imposing liability on the property that is issued or made on or after the day of sale, and does not relate to periodic outgoings.

28.3 The purchaser may enter the property to comply with that responsibility where action is required before settlement.

29. INSPECTION

The purchaser and/or another person authorised by the purchaser may inspect the property at any reasonable time during the 7 days preceding and including the settlement day.

30. TERMS CONTRACT

30.1 If this is a 'terms contract' as defined in the *Sale of Land Act 1962*:

- (a) any mortgage affecting the land sold must be discharged as to that land before the purchaser becomes entitled to Possession or to the receipt of rents and profits unless the vendor satisfies section 29M of the *Sale of Land Act 1962*; and
- (b) the deposit and all other money payable under the contract (other than any money payable in excess of the amount required to so discharge the mortgage) must be paid to a legal practitioner or conveyancer or a licensed estate agent to be applied in or towards discharging the mortgage.

30.2 While any money remains owing each of the following applies:

- (a) the purchaser must maintain full damage and destruction insurance of the property and public risk insurance noting all parties having an insurable interest with an insurer approved in writing by the vendor;
- (b) the purchaser must deliver copies of the signed insurance application forms, the policies and insurance receipts to the vendor not less than 10 days before taking possession of the property or becoming entitled to receipt of the rents and profits;
- (c) the purchaser must deliver copies of any amendments to the policies and the insurance receipts on each amendment or renewal as evidence of the status of the policies from time to time;
- (d) the vendor may pay any renewal premiums or take out the insurance if the purchaser fails to meet these obligations;
- (e) insurance costs paid by the vendor under paragraph (d) must be refunded by the purchaser on demand without affecting the vendor's other rights under this contract;
- (f) the purchaser must maintain and operate the property in good repair (fair wear and tear excepted) and keep the property safe, lawful, structurally sound, weatherproof and free from contaminations and dangerous substances;
- (g) the property must not be altered in any way without the written consent of the vendor which must not be unreasonably refused or delayed;
- (h) the purchaser must observe all obligations that affect owners or occupiers of land;
- (i) the vendor and/or other person authorised by the vendor may enter the property at any reasonable time to inspect it on giving 7 days written notice, but not more than twice in a year.

31. LOSS OR DAMAGE BEFORE SETTLEMENT

31.1 The vendor carries the risk of loss or damage to the property until settlement.

31.2 The vendor must deliver the property to the purchaser at settlement in the same condition it was in on the day of sale, except fair wear and tear.

31.3 The purchaser must not delay settlement because one or more of the goods is not in the condition required by general condition 31.2, but may claim compensation from the vendor after settlement.

- 31.4 The purchaser may nominate an amount not exceeding \$5,000 to be held by the stakeholder to be appointed by the parties if the property is not in the condition required by general condition 31.2 at settlement.
- 31.5 The nominated amount may be deducted from the amount due to the vendor at settlement and paid to the stakeholder, but only if the purchaser also pays an amount equal to the nominated amount to the stakeholder.
- 31.6 The stakeholder must pay the amounts referred to in general condition 31.5 in accordance with the determination of the dispute, including any order for payment of the costs of the resolution of the dispute.

32. BREACH

A party who breaches this contract must pay to the other party on demand:

- (a) compensation for any reasonable foreseeable loss to the other party resulting from the breach; and
- (b) any interest due under this contract as a result of the breach.

Default

33. INTEREST

Interest at a rate of 2% per annum plus the rate for the time being fixed by section 2 of the *Penalty Interest Rates Act 1983* is payable at settlement on any money owing under the contract during the period of default, without affecting any other rights of the offended party.

34. DEFAULT NOTICE

- 34.1 A party is not entitled to exercise any rights arising from the other party's default, other than the right to receive interest and the right to sue for money owing, until the other party is given and fails to comply with a written default notice.
- 34.2 The default notice must:
- (a) specify the particulars of the default; and
 - (b) state that it is the offended party's intention to exercise the rights arising from the default unless, within 14 days of the notice being given –
 - (i) the default is remedied; and
 - (ii) the reasonable costs incurred as a result of the default and any interest payable are paid.

35. DEFAULT NOT REMEDIED

- 35.1 All unpaid money under the contract becomes immediately payable to the vendor if the default has been made by the purchaser and is not remedied and the costs and interest are not paid.
- 35.2 The contract immediately ends if:
- (a) the default notice also states that unless the default is remedied and the reasonable costs and interest are paid, the contract will be ended in accordance with this general condition; and
 - (b) the default is not remedied and the reasonable costs and interest are not paid by the end of the period of the default notice.
- 35.3 If the contract ends by a default notice given by the purchaser:
- (a) the purchaser must be repaid any money paid under the contract and be paid any interest and reasonable costs payable under the contract; and
 - (b) all those amounts are a charge on the land until payment; and
 - (c) the purchaser may also recover any loss otherwise recoverable.
- 35.4 If the contract ends by a default notice given by the vendor:
- (a) the deposit up to 10% of the price is forfeited to the vendor as the vendor's absolute property, whether the deposit has been paid or not; and
 - (b) the vendor is entitled to possession of the property; and
 - (c) in addition to any other remedy, the vendor may within one year of the contract ending either:
 - (i) retain the property and sue for damages for breach of contract; or
 - (ii) resell the property in any manner and recover any deficiency in the price on the resale and any resulting expenses by way of liquidated damages; and
 - (d) the vendor may retain any part of the price paid until the vendor's damages have been determined and may apply that money towards those damages, and
 - (e) any determination of the vendor's damages must take into account the amount forfeited to the vendor.
- 35.5 The ending of the contract does not affect the rights of the offended party as a consequence of the default.

GUARANTEE AND INDEMNITY

The following guarantee shall be executed by each person who executed this Contract for and on behalf of the Purchaser (if not the same person) and by each Director of the Purchaser (if the Purchaser is a Corporation):

I/We, _____ of _____
 and _____ of _____

(hereinafter called the "Guarantors") IN CONSIDERATION of the within-named Vendor(s) selling to the within-named Purchaser(s) at our request the land described in the within Contract for the price and upon the terms and conditions contained therein DO HEREBY for ourselves and our respective executors and administrators JOINTLY AND SEVERALLY COVENANT with the said Vendor(s) and their assigns that if at any time default shall be made in payment of the deposit or residue of purchase money or interest or any other moneys payable by the Purchaser(s) to the Vendor(s) under the within Contract or in the performance or observance of any term or condition of the within Contract to be performed or observed by the Purchaser(s) I/we will forthwith on demand by the Vendor(s) pay to the Vendor(s) the whole of the deposit money, residue of purchase money, interest or other moneys which shall then be due and payable to the Vendor(s) and hereby indemnify and agree to keep the Vendor(s) indemnified against all loss of deposit money, residue of purchase money, interest and other moneys payable under the within Contract and all losses, costs, charges and expenses whatsoever which the Vendor(s) may incur by reason of any default on the part of the Purchaser(s). This Guarantee shall be a continuing Guarantee and Indemnity and shall not be released by:-

- (a) any neglect or forbearance on the part of the Vendor(s) in enforcing payment of any of the moneys payable under the within Contract;
- (b) the performance or observance of any of the agreements, obligations or conditions under the within Contract;
- (c) by time given to the Purchaser(s) for any such payment performance or observance;
- (d) by reason of the Vendor(s) assigning his, her or their rights under the said Contract; and
- (e) by any other thing which under the law relating to sureties would but for this provision have the effect of releasing us, our executors or administrators.

IN WITNESS whereof the parties hereto have set their hands and seals the _____ day of _____ 20____

SIGNED SEALED AND DELIVERED by the said _____)
)
 in the presence of: _____)

.....witness

SIGNED SEALED AND DELIVERED by the said _____)
)
 in the presence of: _____)

.....witness

Sale of Land (Public Auctions) Regulations 2014

S.R. No. 73/2014

TABLE OF PROVISIONS

| <i>Regulation</i> | <i>Page</i> |
|--|-------------|
| 1 Objectives | 1 |
| 2 Authorising provision | 1 |
| 3 Commencement | 2 |
| 4 Revocation | 2 |
| 5 Standard rules for the conduct of public auctions for the sale of land | 2 |
| 6 Information made available at auctions | 2 |
| 7 Announcements by auctioneer before bidding starts | 5 |
| 8 Auctioneer must indicate bidders on request | 7 |
| <hr/> | |
| SCHEDULES | 8 |
| SCHEDULE 1—General Rules for the Conduct of Public Auctions of Land | 8 |
| SCHEDULE 2—Rules for the Conduct of Public Auctions of Land—One Vendor Intends to Bid to Purchase | 9 |
| SCHEDULE 3—Rules for the Conduct of Public Auctions of Land—Some Vendors Intend to Bid to Purchase | 10 |
| SCHEDULE 4—Rules for the Conduct of Public Auctions of Land—All Vendors Intend to Bid to Purchase | 11 |
| SCHEDULE 5—Information Concerning the Conduct of Public Auctions of Land | 12 |
| <hr/> | |
| ENDNOTES | 16 |

STATUTORY RULES 2014

S.R. No. 73/2014

Sale of Land Act 1962

Sale of Land (Public Auctions) Regulations 2014

The Lieutenant-Governor as the Governor's deputy with the advice of the Executive Council makes the following Regulations:

Dated: 24 June 2014

Responsible Minister:

HEIDI VICTORIA
Minister for Consumer Affairs

YVETTE CARISBROOKE
Clerk of the Executive Council

1 Objectives

The objectives of these Regulations are—

- (a) to prescribe standard rules for public auctions for the sale of land; and
- (b) to prescribe written information statements that must be made available for public auctions for the sale of land, and to prescribe how that information is to be made available; and
- (c) to prescribe the obligations of auctioneers at public auctions for the sale of land.

2 Authorising provision

These Regulations are made under section 48 of the **Sale of Land Act 1962**.

3 Commencement

These Regulations come into operation on 1 October 2014.

4 Revocation

The Sale of Land Regulations 2005¹ are **revoked**.

5 Standard rules for the conduct of public auctions for the sale of land

- (1) A public auction for the sale of land must be conducted in accordance with the rules set out in Schedule 1 unless subregulation (2), (3) or (4) applies to that auction.
- (2) A public auction for the sale of land must be conducted in accordance with the rules set out in Schedule 2 if there are 2 co-owners of the land and one of the co-owners intends to bid to purchase the interest of the other co-owner in the land.
- (3) A public auction for the sale of land must be conducted in accordance with the rules set out in Schedule 3 if there are more than 2 co-owners of the land and one or more (but not all) of the co-owners intend to bid to purchase the interest of the other co-owner or co-owners in the land.
- (4) A public auction for the sale of land must be conducted in accordance with the rules set out in Schedule 4 if there are 2 or more co-owners of the land and each of the co-owners intend to bid to purchase the interest of the other co-owner or co-owners in the land.

6 Information made available at auctions

- (1) The auctioneer of land at a public auction to which regulation 5(1) applies must ensure that—
 - (a) the rules set out in Schedule 1; and
 - (b) the information in Schedule 5; and
-

- (c) any other conditions applying to the auction—

are available for public inspection for a reasonable time before the auction starts and in any case not less than 30 minutes before the auction starts.

Penalty: 5 penalty units.

Note

This requirement is in addition to the requirements set out in section 43 of the **Sale of Land Act 1962**.

- (2) The auctioneer of land at a public auction to which the rules set out in Schedule 1 apply must ensure that it is clear which of the 2 alternatives to rule 1 applies to that auction.

Penalty: 5 penalty units.

- (3) The auctioneer of land at a public auction to which regulation 5(2) applies must ensure that—

- (a) the rules set out in Schedule 2; and
- (b) the information in Schedule 5; and
- (c) any other conditions applying to the auction—

are available for public inspection for a reasonable time before the auction starts and in any case not less than 30 minutes before the auction starts.

Penalty: 5 penalty units.

Note

This requirement is in addition to the requirements set out in section 43 of the **Sale of Land Act 1962**.

- (4) The auctioneer of land at a public auction to which regulation 5(3) applies must ensure that—

- (a) the rules set out in Schedule 3; and
- (b) the information in Schedule 5; and

- (c) any other conditions applying to the auction—

are available for public inspection for a reasonable time before the auction starts and in any case not less than 30 minutes before the auction starts.

Penalty: 5 penalty units.

Note

This requirement is in addition to the requirements set out in section 43 of the **Sale of Land Act 1962**.

- (5) The auctioneer of land at a public auction to which regulation 5(4) applies must ensure that—
- (a) the rules set out in Schedule 4; and
 - (b) the information in Schedule 5; and
 - (c) any other conditions applying to the auction—

are available for public inspection for a reasonable time before the auction starts and in any case not less than 30 minutes before the auction starts.

Penalty: 5 penalty units.

Note

This requirement is in addition to the requirements set out in section 43 of the **Sale of Land Act 1962**.

- (6) The auctioneer of land at a public auction must ensure that the rules set out in Schedule 1, 2, 3 or 4 that are made available at the auction are printed or typed—
- (a) in plain text in a font of at least 20 point; and
 - (b) in a form that is easily legible; and
 - (c) in a manner that provides a clear contrast between the typeface of the rules and the background on which the rules are printed or typed.

Penalty: 5 penalty units.

7 Announcements by auctioneer before bidding starts

- (1) Before accepting any bid at a public auction for the sale of land, the auctioneer of the land must audibly state—
- (a) that the auction will be conducted in accordance with the rules and any additional conditions that were made available for inspection before the start of the auction; and
 - (b) that the auction rules prohibit an auctioneer from accepting bids or offers for a property after the property has been knocked down to the successful bidder; and
 - (c) that the auctioneer must indicate bidders on request; and
 - (d) that the law—
 - (i) prohibits false bids; and
 - (ii) prohibits major disruptions by bidders; and
 - (iii) prohibits bidders attempting to prevent others from bidding; and
 - (iv) provides for fines for this conduct.

Penalty: 10 penalty units.

- (2) If the rules set out in Schedule 1 apply to a public auction of land and those rules permit the auctioneer to bid on behalf of the vendor, the auctioneer must, in addition to the requirements in subregulation (1), before accepting any bid audibly state—
- (a) the words the auctioneer will use to indicate during the auction that the auctioneer is making a bid on behalf of the vendor; and

(b) that by law only the auctioneer can make a vendor bid.

Penalty: 10 penalty units.

(3) If the rules set out in Schedule 1 apply to a public auction of land and those rules do not permit the auctioneer to bid on behalf of the vendor, the auctioneer of the land must, in addition to the requirements in subregulation (1), before accepting any bid at the auction audibly state that the rules for the conduct of the auction do not permit the making of a bid on behalf of the vendor.

Penalty: 10 penalty units.

(4) If the rules set out in Schedule 2 apply to a public auction of land, the auctioneer must, in addition to the requirements set out in subregulation (1), before accepting any bid audibly state—

(a) that one of the vendors (or their representative) intends to make a bid to purchase the land; and

(b) that only the auctioneer can make a vendor bid on behalf of the vendor who is not bidding to purchase the land; and

(c) the words the auctioneer will use to indicate during the auction that the auctioneer is making a bid on behalf of the vendor who is not bidding to purchase the land.

Penalty: 10 penalty units.

(5) If the rules set out in Schedule 3 apply to a public auction of land, the auctioneer must, in addition to the requirements set out in subregulation (1), before accepting any bid audibly state—

(a) that one or more but not all of the vendors (or their representatives) intends to make a bid to purchase the land; and

- (b) that only the auctioneer can make a vendor bid on behalf of a vendor who is not bidding to purchase the land; and
- (c) the words the auctioneer will use to indicate during the auction that the auctioneer is making a bid on behalf of the vendor who is not bidding to purchase the land.

Penalty: 10 penalty units.

- (6) If the rules set out in Schedule 4 apply to a public auction of land, the auctioneer must, in addition to the requirements set out in subregulation (1), before accepting any bid audibly state—
 - (a) that each of the vendors (or their representatives) intend to bid to purchase the land; and
 - (b) that no vendor bids will be made by the auctioneer.

Penalty: 10 penalty units.

8 Auctioneer must indicate bidders on request

If a person at a public auction for the sale of land asks the auctioneer to indicate the person who made a bid, the auctioneer must indicate the person who made the bid before taking another bid.

Penalty: 10 penalty units.

SCHEDULES

SCHEDULE 1

Regulations 5, 6 and 7

GENERAL RULES FOR THE CONDUCT OF PUBLIC AUCTIONS OF LAND

- *1. No bids may be made on behalf of the vendor of the land.
OR
 - *1. The auctioneer may make one or more bids on behalf of the vendor of the land at any time during the auction.
[*One of these alternatives must be deleted]
 - 2. The auctioneer may refuse any bid.
 - 3. The auctioneer may determine the amount by which the bidding is to be advanced.
 - 4. The auctioneer may withdraw the property from sale at any time.
 - 5. The auctioneer may refer a bid to the vendor at any time before the conclusion of the auction.
 - 6. In the event of a dispute concerning a bid, the auctioneer may re-submit the property for sale at the last undisputed bid or start the bidding again.
 - 7. The auctioneer must not accept any bid or offer for a property that is made after the property has been knocked down to the successful bidder, unless the vendor or successful bidder at the auction refuses to sign the contract of sale following the auction.
 - 8. If a reserve price has been set for the property and the property is passed in below that reserve price, the vendor will first negotiate with the highest bidder for the purchase of the property.
-

SCHEDULE 2

Regulations 5, 6 and 7

RULES FOR THE CONDUCT OF PUBLIC AUCTIONS OF LAND—ONE VENDOR INTENDS TO BID TO PURCHASE

1. The property at this auction is co-owned by two vendors.
One of the vendors intends to bid to purchase the property at this auction from their co-owner. That vendor may make bids personally, or through a representative, but not through the auctioneer.
Only the auctioneer can make a bid for the other vendor.
2. The auctioneer may refuse any bid.
3. The auctioneer may determine the amount by which the bidding is to be advanced.
4. The auctioneer may withdraw the property from sale at any time.
5. The auctioneer may refer a bid to the vendors at any time before the conclusion of the auction.
6. In the event of a dispute concerning a bid, the auctioneer may re-submit the property for sale at the last undisputed bid or start the bidding again.
7. The auctioneer must not accept any bid or offer for a property that is made after the property has been knocked down to the successful bidder, unless the vendor or successful bidder at the auction refuses to sign the contract of sale following the auction.
8. If a reserve price has been set for the property and the property is passed in below that reserve price, the vendor will first negotiate with the highest bidder for the purchase of the property.

SCHEDULE 3

Regulations 5, 6 and 7

RULES FOR THE CONDUCT OF PUBLIC AUCTIONS OF LAND—SOME VENDORS INTEND TO BID TO PURCHASE

1. The property at this auction is co-owned by more than two vendors.

One or more (but not all) of the vendors intend to bid to purchase the property at this auction. They may make bids themselves, or through a representative, but not through the auctioneer.

Only the auctioneer can make a bid for a vendor not bidding to purchase the property.

2. The auctioneer may refuse any bid.
 3. The auctioneer may determine the amount by which the bidding is to be advanced.
 4. The auctioneer may withdraw the property from sale at any time.
 5. The auctioneer may refer a bid to the vendors at any time before the conclusion of the auction.
 6. In the event of a dispute concerning a bid, the auctioneer may re-submit the property for sale at the last undisputed bid or start the bidding again.
 7. The auctioneer must not accept any bid or offer for a property that is made after the property has been knocked down to the successful bidder, unless the vendor or successful bidder at the auction refuses to sign the contract of sale following the auction.
 8. If a reserve price has been set for the property and the property is passed in below that reserve price, the vendor will first negotiate with the highest bidder for the purchase of the property.
-

SCHEDULE 4

Regulations 5, 6 and 7

RULES FOR THE CONDUCT OF PUBLIC AUCTIONS OF LAND—ALL VENDORS INTEND TO BID TO PURCHASE

1. The property at this auction is co-owned by two or more vendors.
Each of the vendors intends to bid to purchase the property at this auction. They may make bids themselves, or through a representative, but not through the auctioneer.
The auctioneer cannot make a bid at this auction.
2. The auctioneer may refuse any bid.
3. The auctioneer may determine the amount by which the bidding is to be advanced.
4. The auctioneer may withdraw the property from sale at any time.
5. The auctioneer may refer a bid to the vendors at any time before the conclusion of the auction.
6. In the event of a dispute concerning a bid, the auctioneer may re-submit the property for sale at the last undisputed bid or start the bidding again.
7. The auctioneer must not accept any bid or offer for a property that is made after the property has been knocked down to the successful bidder, unless the vendor or successful bidder at the auction refuses to sign the contract of sale following the auction.
8. If a reserve price has been set for the property and the property is passed in below that reserve price, the vendor will first negotiate with the highest bidder for the purchase of the property.

SCHEDULE 5

Regulation 6

INFORMATION CONCERNING THE CONDUCT OF PUBLIC AUCTIONS OF LAND

Meaning of vendor

The vendor is the person who is selling the property that is being auctioned. There may be more than one vendor. Where there are two or more vendors, they are selling the property as co-owners.

Bidding by co-owners

Where there are two or more vendors of the property, one or some or all of them may bid to purchase the property from their co-owners. The vendor or vendors intending to bid to purchase the property can make these bids themselves, or through a representative, but not through the auctioneer.

Vendor bids

The law of Victoria allows vendors to choose to have bids made for them by the auctioneer. If this is the case, it will be stated as the first rule applying to the auction. However, these bids cannot be made for a co-owner intending to bid to purchase the property from their co-owner or co-owners.

The auctioneer can only make a vendor bid if—

- the auctioneer declares before bidding starts that the auctioneer can make bids on behalf of a vendor, and states how these bids will be made; and
 - the auctioneer states when making the bid that it is a bid for the vendors. The usual way for an auctioneer to indicate that the auctioneer is making a vendor bid is to say "vendor bid" in making the bid.
-

What rules and conditions apply to the auction?

Different rules apply to an auction depending upon whether there are any co-owners intending to bid to purchase the property from their co-owners, and whether vendor bids can be made. The auctioneer must display the rules that apply at the auction.

It is possible that a vendor may choose to have additional conditions apply at the auction. This is only allowed if those additional conditions do not conflict with the rules that apply to the auction or any other legal requirement. The additional conditions are usually contained in the contract of sale.

Copies of the rules

The law requires that a copy of the rules and conditions that are to apply to a public auction of land be made available for public inspection a reasonable time before the auction starts and in any case not less than 30 minutes before the auction starts.

Questions

A person at a public auction of land may ask the auctioneer in good faith a reasonable number of questions about the property being sold, the contract of sale, the rules under which the auction is being conducted and the conduct of the auction.

Forbidden activities at auctions

The law forbids any of the following—

- any person bidding for a vendor other than—
 - the auctioneer (who can only make bids for a vendor who does not intend to purchase the property from their co-owner or co-owners); or
 - a representative of a vendor who is a co-owner of the property wishing to purchase the property from their co-owner or co-owners;

- the auctioneer taking any bid that the auctioneer knows was made on behalf of the vendor, unless it is made by a vendor (or their representative) who is a co-owner wishing to purchase the property;
- the auctioneer acknowledging a bid if no bid was made;
- any person asking another person to bid on behalf of the vendor, other than a vendor who is a co-owner engaging a representative to bid for them;
- any person falsely claiming or falsely acknowledging that they made a bid;
- an intending bidder (or a person acting on behalf of an intending bidder) harassing or interfering with other bidders at a public auction of land.

Substantial penalties apply to any person who does any of the things in this list.

Who made the bid?

At any time during a public auction of land, a person at the auction may ask the auctioneer to indicate who made a bid. Once such a request has been made, the auctioneer is obliged by law to comply with such a request before taking another bid.

It is an offence to disrupt an auction

The law forbids an intending bidder or a person acting on behalf of an intending bidder from doing any thing with the intention of preventing or causing a major disruption to, or causing the cancellation of, a public auction of land.

The cooling off period does not apply to public auctions of land

If you purchase a property that has been offered for sale by public auction either at the auction or within 3 clear business days before or after the auction, there is no cooling off period.

What law applies

The information in this document is only intended as a brief summary of the law that applies to public auctions of land in Victoria. Most of the laws referred to in this document can be found in the **Sale of Land Act 1962** or the Sale of Land (Public Auctions) Regulations 2014. Copies of those laws can be found at the following web site: www.legislation.vic.gov.au under the title "Victorian Law Today".

ENDNOTES

¹ Reg. 4: S.R. No. 28/2005 as amended by S.R. No. 47/2008.

INFORMATION ONLY

Vendor Statement

The vendor makes this statement in respect of the land in accordance with section 32 of the *Sale of Land Act 1962*.

This statement must be signed by the vendor and given to the purchaser before the purchaser signs the contract.
The vendor may sign by electronic signature.

The purchaser acknowledges being given this statement signed by the vendor with the attached documents before the purchaser signed any contract.

| | |
|-------------|--|
| Land | 13 Mulberry Parade, Heidelberg West VIC 3081 |
|-------------|--|

| | | |
|---------------------------|--|--------------------|
| Vendor's name | Joseph Allan Bowden and Sharon Gaye Bowden | Date / / |
| Vendor's signature | | |

| | | |
|------------------------------|--|--------------------|
| Purchaser's name | | Date / / |
| Purchaser's signature | | |

| | | |
|------------------------------|--|--------------------|
| Purchaser's name | | Date / / |
| Purchaser's signature | | |

1. FINANCIAL MATTERS

1.1 Particulars of any Rates, Taxes, Charges or Other Similar Outgoings (and any interest on them)

(a) Their total does not exceed:

\$6,000.00

1.2 Particulars of any Charge (whether registered or not) imposed by or under any Act to secure an amount due under that Act, including the amount owing under the charge:

- Unless contained in the attached certificate or statement, none to the Vendor's knowledge. The Vendor has no means of knowing all decisions of the Government and other Authorities unless such decisions have been communicated to the Vendor.

1.3 Terms Contract

This section 1.3 only applies if this vendor statement is in respect of a terms contract where the purchaser is obliged to make 2 or more payments (other than a deposit or final payment) to the vendor after the execution of the contract and before the purchaser is entitled to a conveyance or transfer of the land.

- Not Applicable.

1.4 Sale Subject to Mortgage

This section 1.4 only applies if this vendor statement is in respect of a contract which provides that any mortgage (whether registered or unregistered), is NOT to be discharged before the purchaser becomes entitled to possession or receipts of rents and profits.

- Not Applicable.

1.5 Commercial and Industrial Property Tax Reform Act 2024 (Vic) (CIPT Act)

| | |
|---|---|
| (a) The Australian Valuation Property Classification Code (within the meaning of the CIPT Act) most recently allocated to the land is set out in the attached Municipal rates notice or property clearance certificate or is as follows | AVPC No. . Please refer to the Property Clearance Certificate attached. |
| (b) Is the land tax reform scheme land within the meaning of the CIPT Act? | <input type="checkbox"/> YES <input checked="" type="checkbox"/> NO |
| (c) If the land is tax reform scheme land within the meaning of the CIPT Act, the entry date within the meaning of the CIPT Act is set out in the attached Municipal rates notice or property clearance certificate or is as follows | Date: OR <input checked="" type="checkbox"/> Not applicable |

2. INSURANCE

2.1 Damage and Destruction

This section 2.1 only applies if this vendor statement is in respect of a contract which does NOT provide for the land to remain at the risk of the vendor until the purchaser becomes entitled to possession or receipt of rents and profits.

- Not Applicable

2.2 Owner Builder

This section 2.2 only applies where there is a residence on the land that was constructed by an owner-builder within the preceding 6 years and section 137B of the Building Act 1993 applies to the residence.

- Not Applicable

3. LAND USE

3.1 Easements, Covenants or Other Similar Restrictions

(a) A description of any easement, covenant or other similar restriction affecting the land (whether registered or unregistered): -

- Is in the attached copies of title documents.

(b) Particulars of any existing failure to comply with that easement, covenant or other similar restriction are:-

To the best of the vendors knowledge there is no existing failure to comply with the terms of any easement, covenant or other similar restriction.

3.2 Road Access

There is NO access to the property by road if the square box is marked with an 'X'

3.3 Designated Bushfire Prone Area

The land is in a designated bushfire prone area within the meaning of regulations made under the *Building Act* 1993 if the square box is marked with an 'X'

3.4 Planning Scheme

Attached is a certificate with the required specified information.

4. NOTICES

4.1 Notice, Order, Declaration, Report or Recommendation

Particulars of any notice, order, declaration, report or recommendation of a public authority or government department or approved proposal directly and currently affecting the land, being a notice, order, declaration, report, recommendation or approved proposal of which the vendor might reasonably be expected to have knowledge:

- Not Applicable.

5. BUILDING PERMITS

Particulars of any building permit issued under the *Building Act* 1993 in the preceding 7 years (required only where there is a residence on the land):

- Not Applicable.

6. OWNERS CORPORATION

6.1 This section 6 only applies if the land is affected by an owners corporation within the meaning of the *Owners Corporations Act* 2006.

- Not Applicable.

7. GROWTH AREAS INFRASTRUCTURE CONTRIBUTION ("GAIC")

- Not Applicable.

8. SERVICES

The services which are marked with an 'X' in the accompanying square box are NOT connected to the land:

| | | | | |
|---|-------------------------------------|---------------------------------------|-----------------------------------|--|
| Electricity supply <input type="checkbox"/> | Gas supply <input type="checkbox"/> | Water supply <input type="checkbox"/> | Sewerage <input type="checkbox"/> | Telephone services <input checked="" type="checkbox"/> |
|---|-------------------------------------|---------------------------------------|-----------------------------------|--|

Connected indicates that the service is provided by an authority and operating on the day of sale. The Purchaser should be aware that the Vendor may terminate their account with the service provider prior to settlement and the Purchaser will have to have the services reconnected. It is the Purchaser's responsibility to check with the appropriate authorities as to the availability of and the costs of connecting or reconnecting to the property any of the services required. Unless the Purchaser contacts the supplier authority and takes over the existing service, final reading will be obtained and all services will be disconnected at settlement. It will be the Purchaser's responsibility to pay all costs of and incidental to connections or reconnections of the services required.

9. TITLE

Attached are copies of the following documents:

- 9.1 Registered Title
- 9.2 A Register Search Statement and the document, or part of a document, referred to as the 'diagram location' in that statement which identifies the land and its location.

10. SUBDIVISION

10.1 Unregistered Subdivision

This section 10.1 only applies if the land is subject to a subdivision which is not registered.

- Not Applicable.

10.2 Staged Subdivision

This section 10.2 only applies if the land is part of a staged subdivision within the meaning of section 37 of the *Subdivision Act 1988*.

- Not Applicable.

10.3 Further Plan of Subdivision

This section 10.3 only applies if the land is subject to a subdivision in respect of which a further plan within the meaning of the *Subdivision Act 1988* is proposed.

- Not Applicable.

11. DISCLOSURE OF ENERGY INFORMATION

(Disclosure of this information is not required under section 32 of the Sale of Land Act 1962 but may be included in this vendor statement for convenience.)

Details of any energy efficiency information required to be disclosed regarding a disclosure affected building or disclosure area affected area of a building as defined by the *Building Energy Efficiency Disclosure Act 2010* (Cth)

- (a) to be a building or part of a building used or capable of being used as an office for administrative, clerical, professional or similar based activities including any support facilities; and
- (b) which has a net lettable area of at least 2000m²; (but does not include a building under a strata title system or if an occupancy permit was issued less than 2 years before the relevant date):
 - Not Applicable.

12. DUE DILIGENCE CHECKLIST

(The Sale of Land Act 1962 provides that the vendor or the vendor's licensed estate agent must make a prescribed due diligence checklist available to purchasers before offering land for sale that is vacant residential land or land on which there is a residence. The due diligence checklist is NOT required to be provided with, or attached to, this vendor statement but the checklist may be attached as a matter of convenience.)

- See attached.

13. ATTACHMENTS

(Any certificates, documents and other attachments may be annexed to this section 13)

(Additional information may be added to this section 13 where there is insufficient space in any of the earlier sections)

(Attached is an "Additional Vendor Statement" if section 1.3 (Terms Contract) or section 1.4 (Sale Subject to Mortgage) applies)

| |
|--|
| |
|--|

**REGISTER SEARCH STATEMENT (Title Search) Transfer of
Land Act 1958**

Page 1 of 1

VOLUME 08541 FOLIO 028

Security no : 124129982430D
Produced 17/11/2025 07:47 PM

LAND DESCRIPTION

Lot 521 on Plan of Subdivision 033339.
PARENT TITLE Volume 08086 Folio 161
Created by instrument 4435769R 26/03/1965

REGISTERED PROPRIETOR

Estate Fee Simple
Joint Proprietors
JOSEPH ALLAN BOWDEN
SHARON GAYE BOWDEN both of 13 MULBERRY PD WEST HEIDELBERG 3081
T900064L 06/10/1995

ENCUMBRANCES, CAVEATS AND NOTICES

MORTGAGE AH723072K 12/01/2011
COMMONWEALTH BANK OF AUSTRALIA

Any encumbrances created by Section 98 Transfer of Land Act 1958 or Section 24 Subdivision Act 1988 and any other encumbrances shown or entered on the plan or imaged folio set out under DIAGRAM LOCATION below.

DIAGRAM LOCATION

SEE LP033339 FOR FURTHER DETAILS AND BOUNDARIES

ACTIVITY IN THE LAST 125 DAYS

NIL

-----END OF REGISTER SEARCH STATEMENT-----

Additional information: (not part of the Register Search Statement)

Street Address: 13 MULBERRY PARADE HEIDELBERG WEST VIC 3081

ADMINISTRATIVE NOTICES

NIL

eCT Control 15940N COMMONWEALTH BANK OF AUSTRALIA
Effective from 23/10/2016

DOCUMENT END

Imaged Document Cover Sheet

The document following this cover sheet is an imaged document supplied by LANDATA®, Secure Electronic Registries Victoria.

| | |
|---|-------------------------|
| Document Type | Plan |
| Document Identification | LP033339 |
| Number of Pages (excluding this cover sheet) | 4 |
| Document Assembled | 17/11/2025 19:47 |

Copyright and disclaimer notice:

© State of Victoria. This publication is copyright. No part may be reproduced by any process except in accordance with the provisions of the Copyright Act 1968 (Cth) and for the purposes of Section 32 of the Sale of Land Act 1962 or pursuant to a written agreement. The information is only valid at the time and in the form obtained from the LANDATA® System. None of the State of Victoria, LANDATA®, Secure Electronic Registries Victoria Pty Ltd (ABN 86 627 986 396) as trustee for the Secure Electronic Registries Victoria Trust (ABN 83 206 746 897) accept responsibility for any subsequent release, publication or reproduction of the information.

The document is invalid if this cover sheet is removed or altered.

PLAN OF SUBDIVISION OF PART OF
HEIDELBERG WEST ESTATE
HOUSING COMMISSION OF VICTORIA
PART OF CROWN PORTION THREE

LP 33339
EDITION 2
PLAN MAY BE LODGED
17-5-1956

PARISH OF KEELBUNDORA

3 SHEETS
SHEET 1

Measurements are in Feet & Inches
Conversion Factor
FEET x 0.3048 = METRES

COUNTY OF BOURKE

V 8086 F 161

SEE SHEET 2

GONA

75° 47'

STREET

PARADE

STREET

APPROPRIATIONS

THE LAND MARKED E-1 IS APPROPRIATED OR SET APART FOR EASEMENTS OF DRAINAGE, SEWERAGE AND GAS AND IS SIX FEET WIDE

ENCUMBRANCES

AS TO THE LAND MARKED E-2: THE PARTY WALL EASEMENT IN FAVOUR OF LOT 528 RESERVED IN D407126

AS TO THE LAND MARKED E-3: THE PARTY WALL EASEMENT IN FAVOUR OF LOT 529 CREATED BY D407126

341'26'

341'26'

SEE SHEET 3



LIBERTY

WAU

LAE 75° 00' STREET

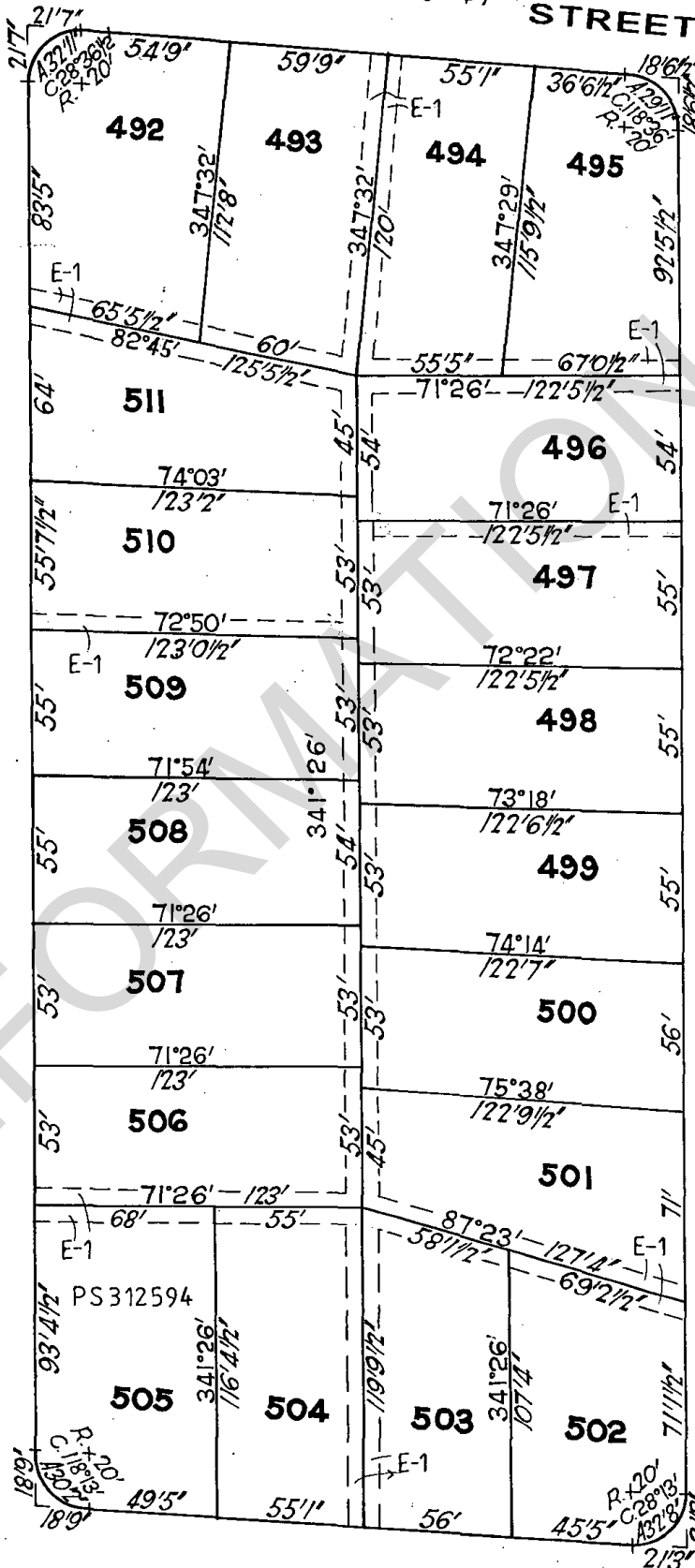

LP 333339

3 SHEETS
SHEET 2

LIBERTY 352°55' PARADE

CARBEENA PARADE

75°47'

75°47'

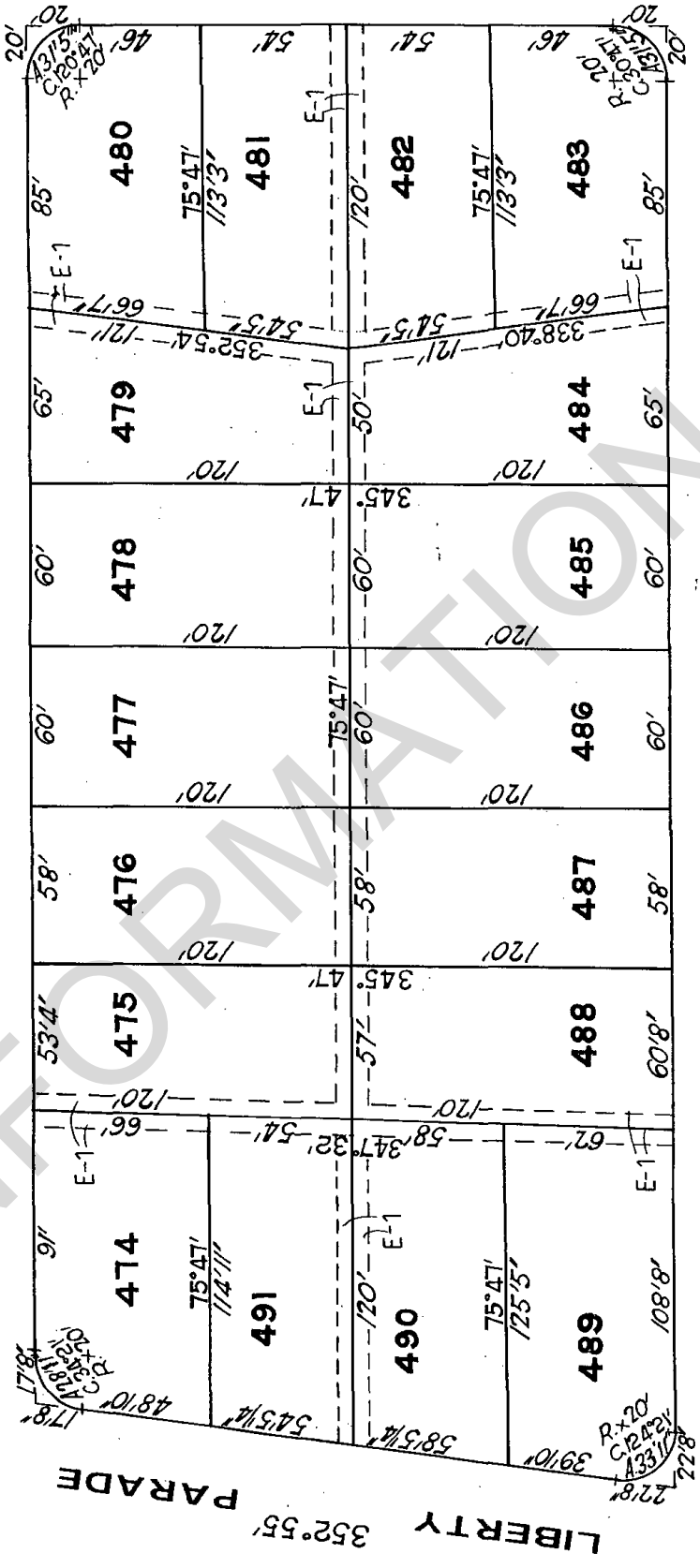

GONA STREET

75°47'

75°47'

75°47'

75°47'

MULBERRY

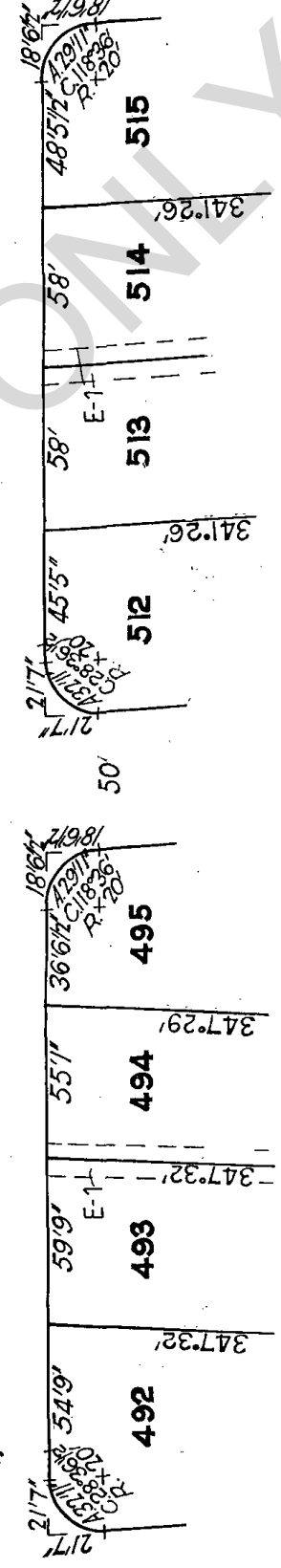

SEE SHEET 3

SEE SHEET 1

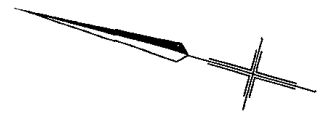

SEE SHEET 2

LP 33339

3 SHEETS
SHEET 3

SEE SHEET 1

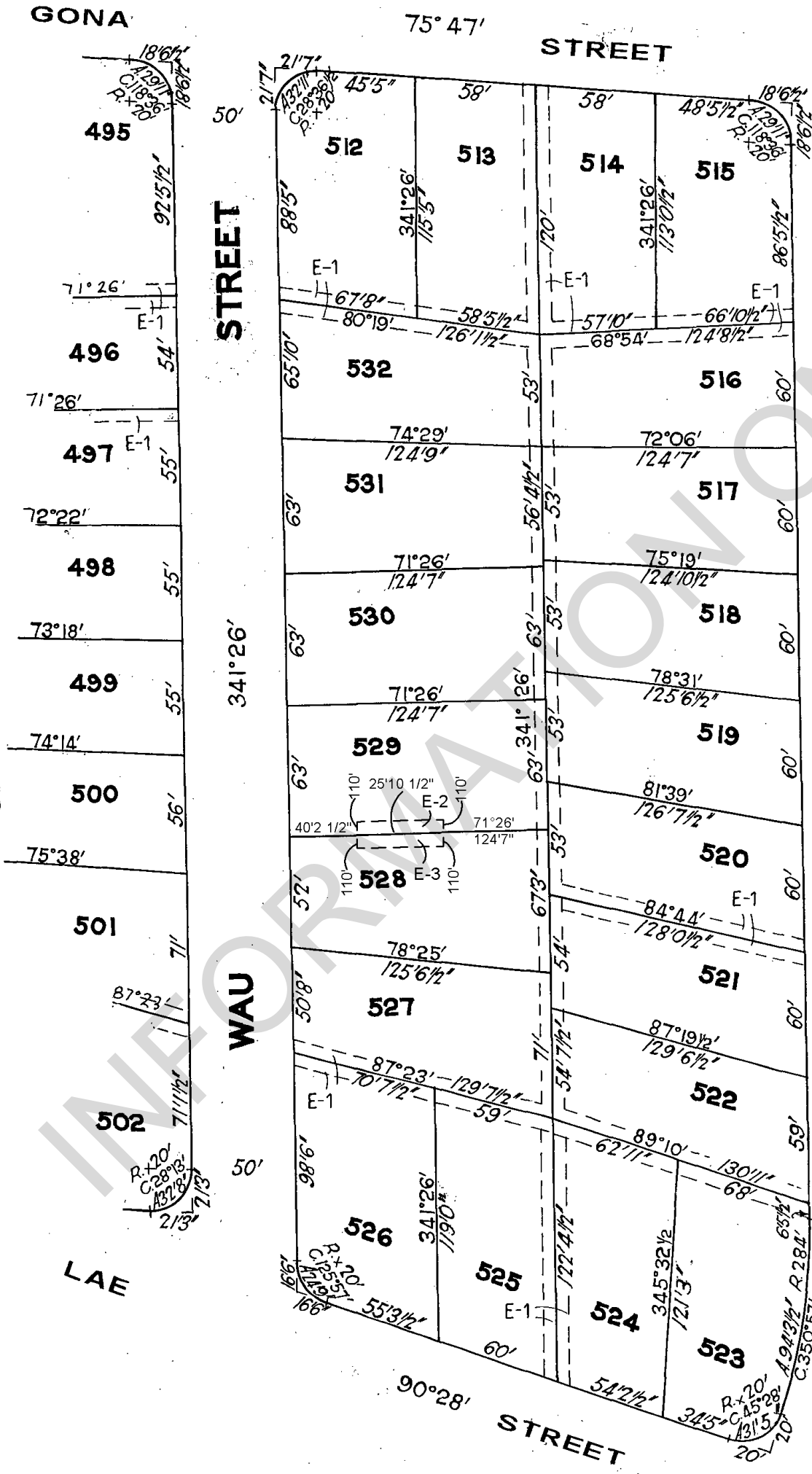

PARADE
341'26"
MULBERRY



PLANNING CERTIFICATE

Official certificate issued under Section 199 Planning & Environment Act 1987
and the Planning and Environment Regulations 2005

CERTIFICATE REFERENCE NUMBER

1200766

APPLICANT'S NAME & ADDRESS

PERFECT CHOICE CONVEYANCING SERVICES C/-
TRICONVEY2 (RESELLER) C/- LANDATA

DOCKLANDS

VENDOR

BOWDEN, JOSEPH ALLAN

PURCHASER

NOT KNOWN, NOT KNOWN

REFERENCE

638708

This certificate is issued for:

LOT 521 PLAN LP33339 ALSO KNOWN AS 13 MULBERRY PARADE HEIDELBERG WEST
BANYULE CITY

The land is covered by the:

BANYULE PLANNING SCHEME

The Minister for Planning is the responsible authority issuing the Certificate.

The land:

- is included in a GENERAL RESIDENTIAL ZONE - SCHEDULE 1
- is within a DEVELOPMENT CONTRIBUTIONS PLAN OVERLAY - SCHEDULE 1
- and a VEGETATION PROTECTION OVERLAY - SCHEDULE 5

A detailed definition of the applicable Planning Scheme is available at :
<http://planningschemes.dpcd.vic.gov.au/schemes/banyule>

Historic buildings and land protected under the Heritage Act 1995 are recorded in the Victorian
Heritage Register at:

<http://vhd.heritage.vic.gov.au/>

17 November 2025

Sonya Kilkenny
Minister for Planning

Additional site-specific controls may apply.
The Planning Scheme Ordinance should be
checked carefully.

The above information includes all
amendments to planning scheme maps
placed on public exhibition up to the date
of issue of this certificate and which are
still the subject of active consideration

Copies of Planning Schemes and
Amendments can be inspected at the
relevant municipal offices.

LANDATA@
T: (03) 9102 0402
E: landata.enquiries@servictoria.com.au

The attached certificate is issued by the Minister for Planning of the State of Victoria and is protected by statute.

The document has been issued based on the property information you provided. You should check the map below - it highlights the property identified from your information.

If this property is different to the one expected, you can phone (03) 9102 0402 or email landata.enquiries@servictoria.com.au

Please note: The map is for reference purposes only and does not form part of the certificate.

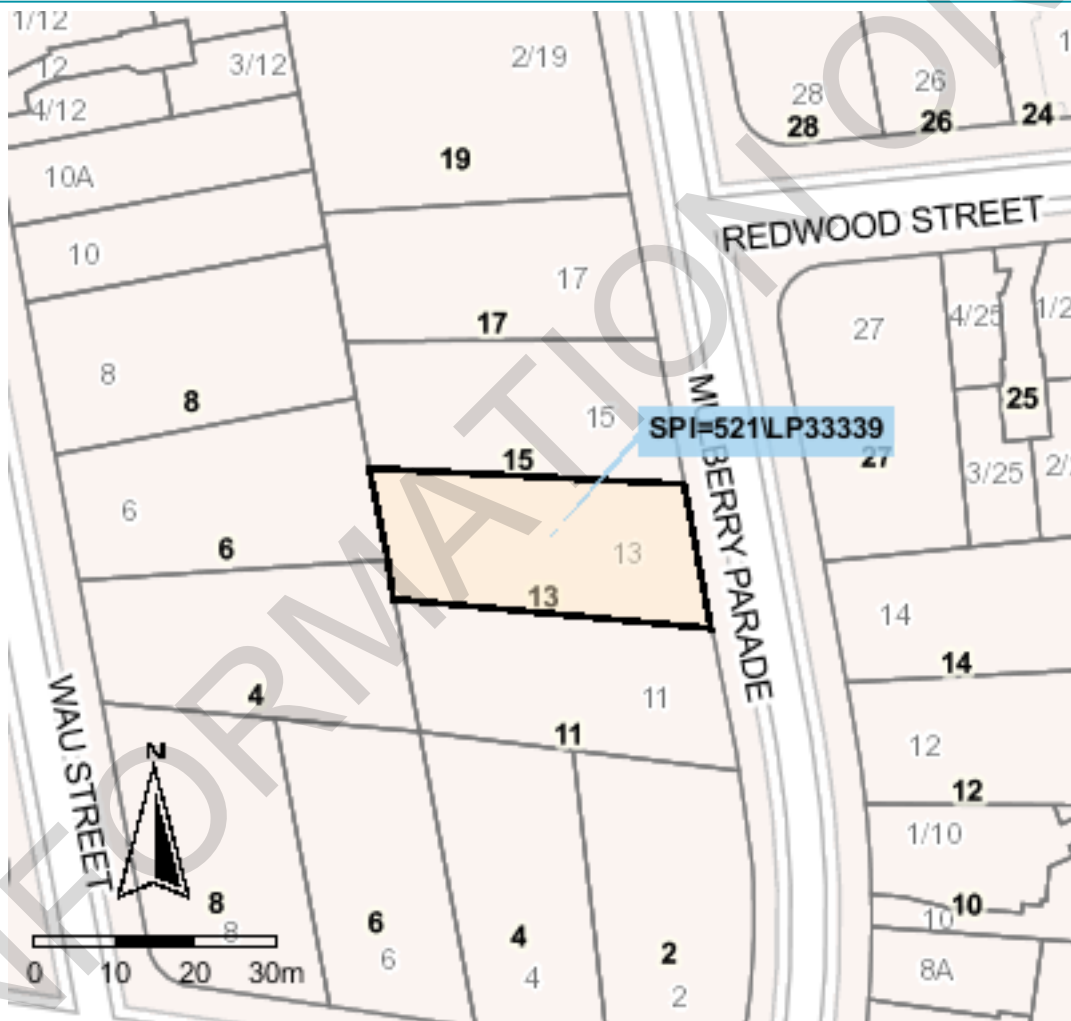

Copyright © State Government of Victoria. Service provided by maps.land.vic.gov.au

Choose the authoritative Planning Certificate

Why rely on anything less?

As part of your section 32 statement, the authoritative Planning Certificate provides you and / or your customer with the statutory protection of the State of Victoria.

Order online before 4pm to receive your authoritative Planning Certificate the same day, in most cases within the hour. Next business day delivery, if further information is required from you.

Privacy Statement

The information obtained from the applicant and used to produce this certificate was collected solely for the purpose of producing this certificate. The personal information on the certificate has been provided by the applicant and has not been verified by LANDATA®. The property information on the certificate has been verified by LANDATA®. The zoning information on the certificate is protected by statute. The information on the certificate will be retained by LANDATA® for auditing purposes and will not be released to any third party except as required by law.

From www.planning.vic.gov.au at 23 November 2025 11:35 PM

PROPERTY DETAILS

Address: **13 MULBERRY PARADE HEIDELBERG WEST 3081**
 Lot and Plan Number: **Lot 521 LP33339**
 Standard Parcel Identifier (SPI): **521\LP33339**
 Local Government Area (Council): **BANYULE**
 Council Property Number: **403337**
 Planning Scheme: **Banyule**
 Directory Reference: **Melway 31 E1**

www.banyule.vic.gov.au

[Planning Scheme - Banyule](#)

UTILITIES

Rural Water Corporation: **Southern Rural Water**
 Melbourne Water Retailer: **Yarra Valley Water**
 Melbourne Water: **Inside drainage boundary**
 Power Distributor: **JEMENA**

STATE ELECTORATES

Legislative Council: **NORTH-EASTERN METROPOLITAN**
 Legislative Assembly: **IVANHOE**
OTHER
 Registered Aboriginal Party: **Wurundjeri Woi Wurrung Cultural Heritage Aboriginal Corporation**
 Fire Authority: **Fire Rescue Victoria**

[View location in VicPlan](#)

Planning Zones

[GENERAL RESIDENTIAL ZONE \(GRZ\)](#)

[GENERAL RESIDENTIAL ZONE - SCHEDULE 1 \(GRZ1\)](#)

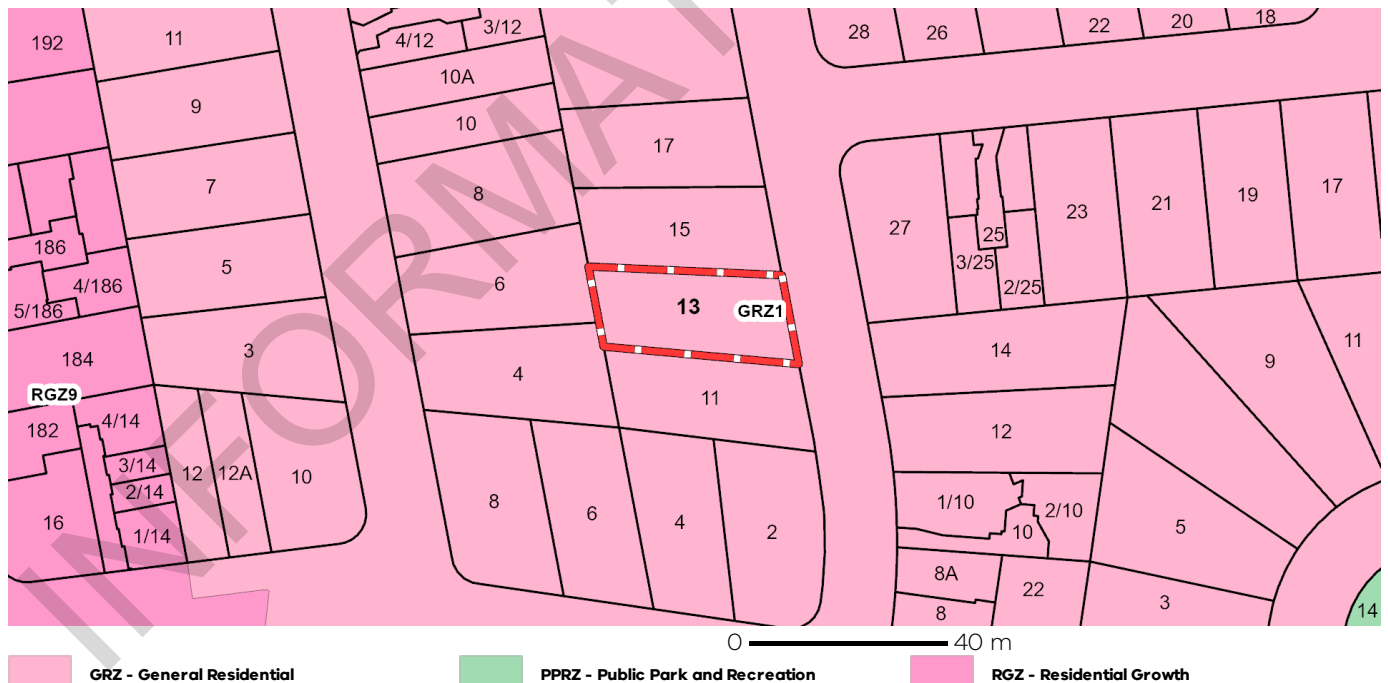

Note: labels for zones may appear outside the actual zone - please compare the labels with the legend.

Copyright © - State Government of Victoria

Disclaimer: This content is provided for information purposes only. No claim is made as to the accuracy or authenticity of the content. The Victorian Government does not accept any liability to any person for the information provided.

Read the full disclaimer at <https://www.vic.gov.au/disclaimer>

Notwithstanding this disclaimer, a vendor may rely on the information in this report for the purpose of a statement that land is in a bushfire prone area as required by section 32C (b) of the Sale of Land 1962 (Vic).

Planning Overlays

DEVELOPMENT CONTRIBUTIONS PLAN OVERLAY (DCPO)

DEVELOPMENT CONTRIBUTIONS PLAN OVERLAY - SCHEDULE 1 (DCPO1)

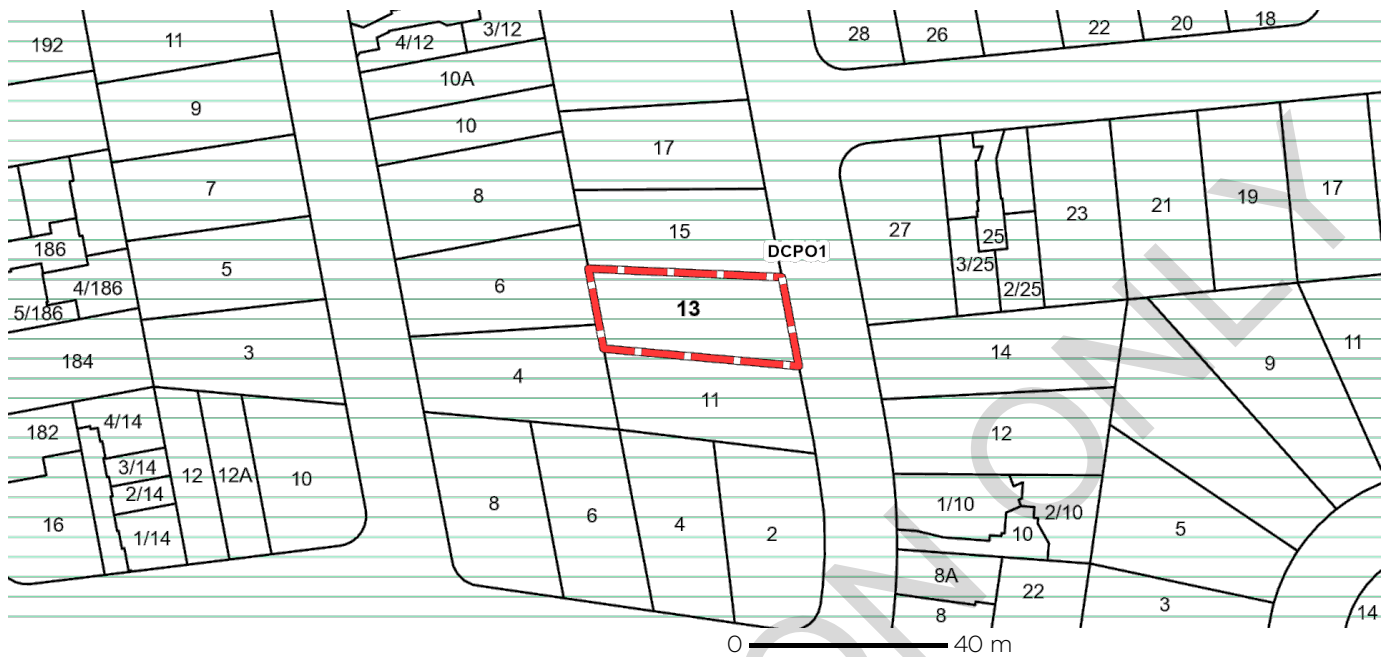

DCPO - Development Contributions Plan Overlay

Note: due to overlaps, some overlays may not be visible, and some colours may not match those in the legend

VEGETATION PROTECTION OVERLAY (VPO)

VEGETATION PROTECTION OVERLAY - SCHEDULE 5 (VPO5)

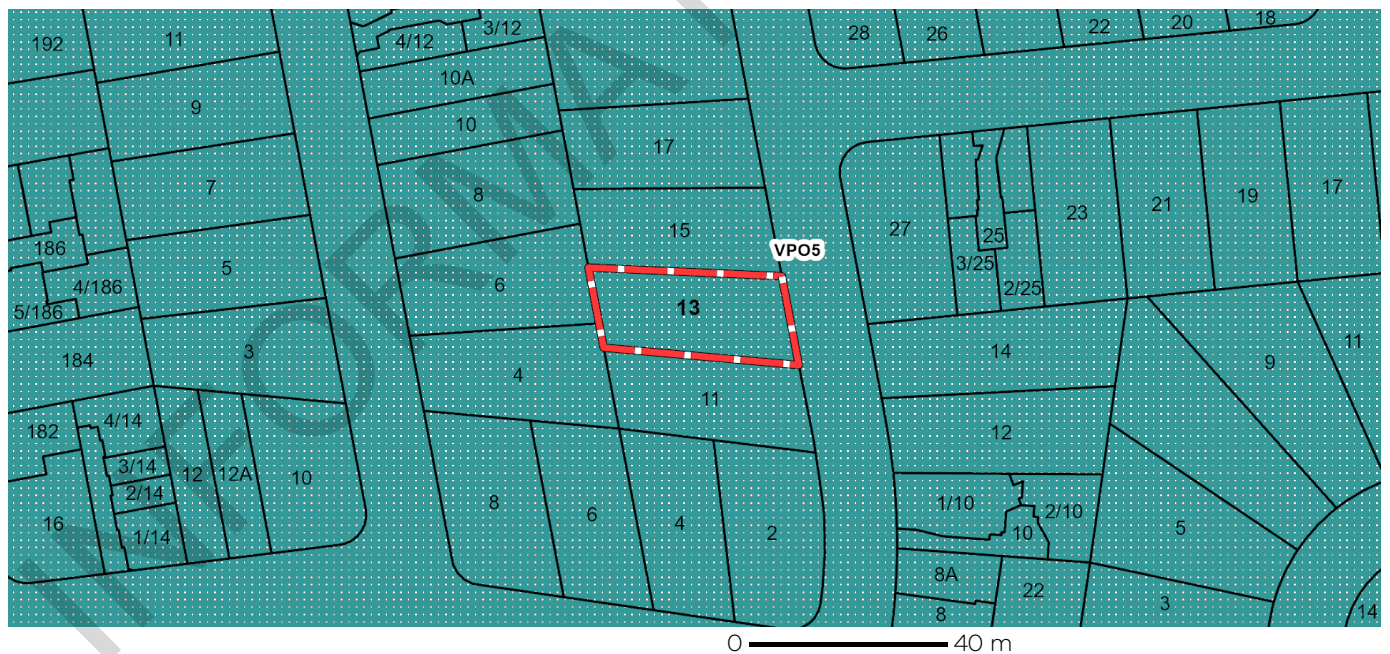

VPO - Vegetation Protection Overlay

Note: due to overlaps, some overlays may not be visible, and some colours may not match those in the legend

Planning Overlays

OTHER OVERLAYS

Other overlays in the vicinity not directly affecting this land

[DESIGN AND DEVELOPMENT OVERLAY \(DDO\)](#)

[ENVIRONMENTAL SIGNIFICANCE OVERLAY \(ESO\)](#)

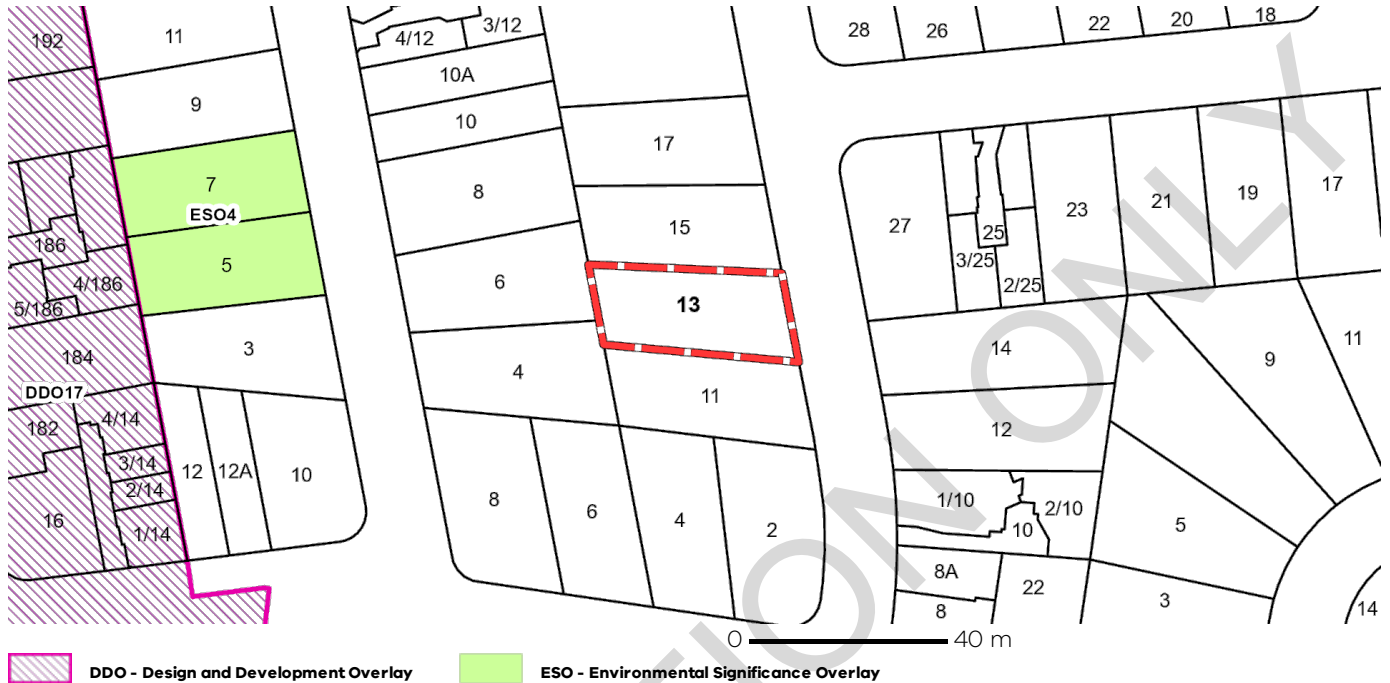

Note: due to overlaps, some overlays may not be visible, and some colours may not match those in the legend

Further Planning Information

Planning scheme data last updated on 14 November 2025.

A **planning scheme** sets out policies and requirements for the use, development and protection of land. This report provides information about the zone and overlay provisions that apply to the selected land. Information about the State and local policy, particular, general and operational provisions of the local planning scheme that may affect the use of this land can be obtained by contacting the local council or by visiting <https://www.planning.vic.gov.au>

This report is NOT a **Planning Certificate** issued pursuant to Section 199 of the **Planning and Environment Act 1987**. It does not include information about exhibited planning scheme amendments, or zonings that may affect the land. To obtain a Planning Certificate go to Titles and Property Certificates at Landata - <https://www.landata.vic.gov.au>

For details of surrounding properties, use this service to get the Reports for properties of interest.

To view planning zones, overlay and heritage information in an interactive format visit <https://mapshare.vic.gov.au/vicplan/>

For other information about planning in Victoria visit <https://www.planning.vic.gov.au>

Designated Bushfire Prone Areas

This property is not in a designated bushfire prone area.
No special bushfire construction requirements apply. Planning provisions may apply.

Where part of the property is mapped as BPA, if no part of the building envelope or footprint falls within the BPA area, the BPA construction requirements do not apply.

Note: the relevant building surveyor determines the need for compliance with the bushfire construction requirements.

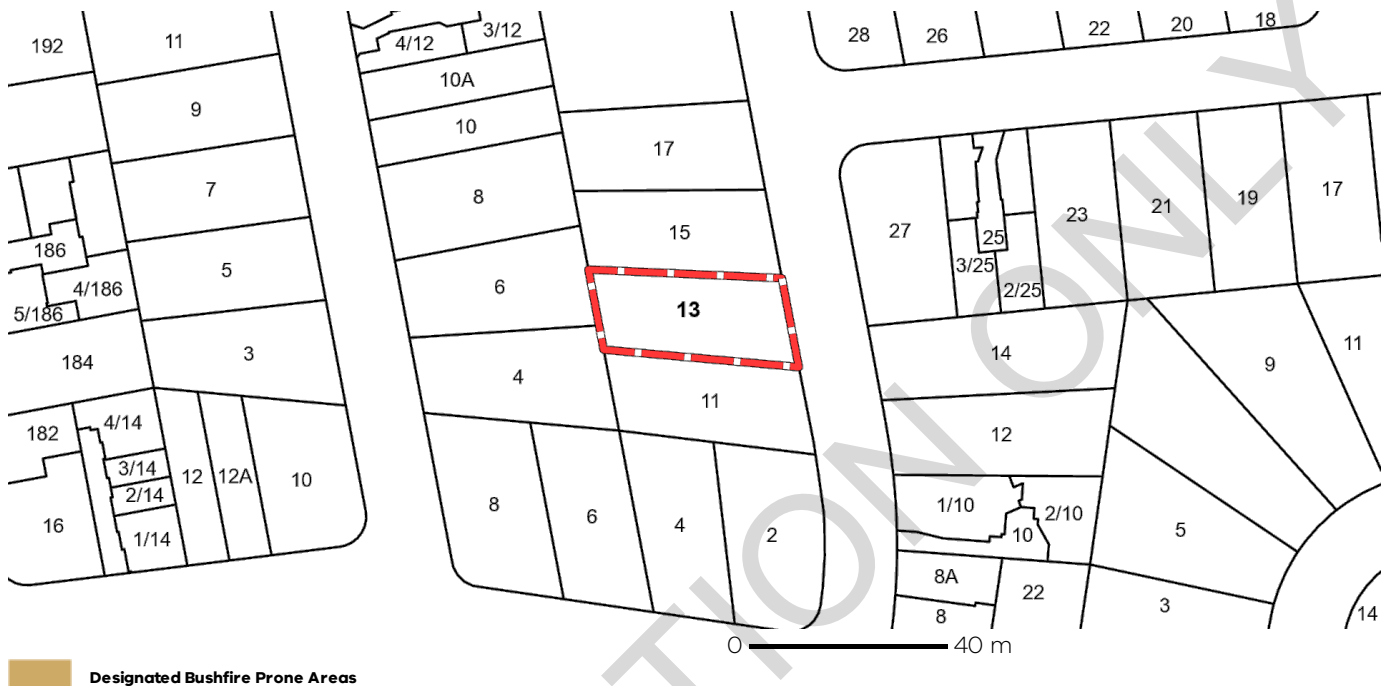

Designated BPA are determined by the Minister for Planning following a detailed review process. The Building Regulations 2018, through adoption of the Building Code of Australia, apply bushfire protection standards for building works in designated BPA.

Designated BPA maps can be viewed on VicPlan at <https://mapshare.vic.gov.au/vicplan/> or at the relevant local council.

Create a BPA definition plan in [VicPlan](#) to measure the BPA.

Information for lot owners building in the BPA is available at <https://www.planning.vic.gov.au>.

Further information about the building control system and building in bushfire prone areas can be found on the Victorian Building Authority website <https://www.vba.vic.gov.au>. Copies of the Building Act and Building Regulations are available from <http://www.legislation.vic.gov.au>. For Planning Scheme Provisions in bushfire areas visit <https://www.planning.vic.gov.au>.

Native Vegetation

Native plants that are indigenous to Victoria and important for biodiversity might be present on this property. This could include trees, shrubs, herbs, grasses or aquatic plants. There are a range of regulations that may apply including need to obtain a planning permit under Clause 52.17 of the local planning scheme. For more information see [Native Vegetation \(Clause 52.17\)](#) with local variations in [Native Vegetation \(Clause 52.17\) Schedule](#)

To help identify native vegetation on this property and the application of Clause 52.17 please visit the Native Vegetation Regulations Map (NVR Map) <https://mapshare.vic.gov.au/nvr/> and [Native vegetation \(environment.vic.gov.au\)](#) or please contact your relevant council.

You can find out more about the natural values on your property through NatureKit [NatureKit \(environment.vic.gov.au\)](#)

Created at 23 November 2025 03:26 PM

PROPERTY DETAILS

Address: **13 MULBERRY PARADE HEIDELBERG WEST 3081**
Lot and Plan Number: **Lot 521 LP33339**
Standard Parcel Identifier (SPI): **521\LP33339**
Local Government Area (Council): **BANYULE**
Council Property Number: **403337**
Directory Reference: **Melway 31 E1**

www.banyule.vic.gov.au

SITE DIMENSIONS

All dimensions and areas are approximate. They may not agree with those shown on a title or plan.

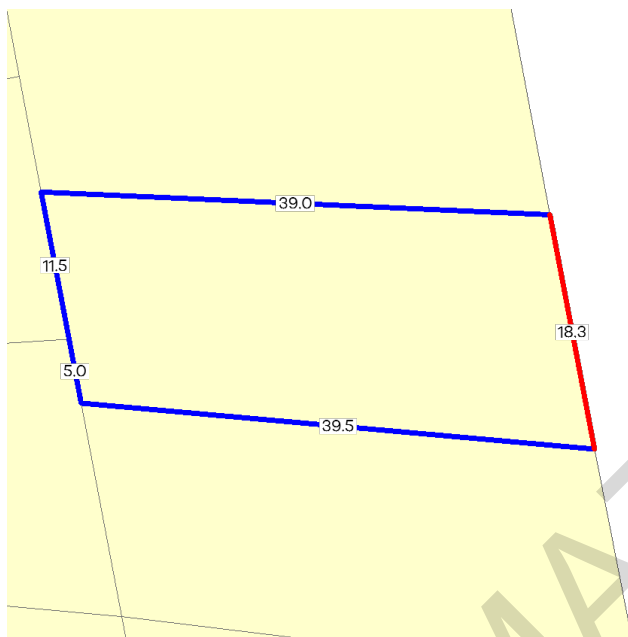

Area: 659 sq. m

Perimeter: 113 m

For this property:

— Site boundaries

— Road frontages

Dimensions for individual parcels require a separate search, but dimensions for individual units are generally not available.

Calculating the area from the dimensions shown may give a different value to the area shown above

For more accurate dimensions get copy of plan at

[Title and Property Certificates](#)

UTILITIES

Rural Water Corporation: **Southern Rural Water**
Melbourne Water Retailer: **Yarra Valley Water**
Melbourne Water: **Inside drainage boundary**
Power Distributor: **JEMENA**

STATE ELECTORATES

Legislative Council: **NORTH-EASTERN METROPOLITAN**
Legislative Assembly: **IVANHOE**

PLANNING INFORMATION

Property Planning details have been removed from the Property Reports to avoid duplication with the Planning Property Reports from the Department of Transport and Planning which are the authoritative source for all Property Planning information.

The Planning Property Report for this property can found here - [Planning Property Report](#)

Planning Property Reports can be found via these two links

Vicplan <https://mapshare.vic.gov.au/vicplan/>

Property and parcel search <https://www.land.vic.gov.au/property-and-parcel-search>

Area Map



 Selected Property

Details

LOT/PLAN NUMBER OR CROWN DESCRIPTION

Lot. 521 LP33339

LOCAL GOVERNMENT (COUNCIL)

Banyule

LEGAL DESCRIPTION

521\LP33339

COUNCIL PROPERTY NUMBER

403337

LAND SIZE

 Premium report only

ORIENTATION

 Premium report only

FRONTAGE

 Premium report only

ZONES

GRZ - General Residential Zone - Schedule 1

OVERLAYS

DCPO - Development Contributions Plan Overlay - Schedule 1

VPO - Vegetation Protection Overlay - Schedule 5

State Electorates

LEGISLATIVE COUNCIL

North-Eastern Metropolitan Region

LEGISLATIVE ASSEMBLY

Ivanhoe District

Burglary Statistics

POSTCODE AVERAGE

1 in 42 Homes

STATE AVERAGE

1 in 76 Homes

COUNCIL AVERAGE

1 in 74 Homes

Council Information - Banyule

PHONE

03 9457 9808 (Banyule)

EMAIL

enquiries@banyule.vic.gov.au

WEBSITE

<http://www.banyule.vic.gov.au/>

PREMIUM REPORT \$24.90 - Includes:

Visit landchecker.com.au to view plans



Planning Permits
Approved and Pending



Planning Scheme Amendments
90 days Proposed and Approved



Site Dimensions
Approximate Site Dimensions

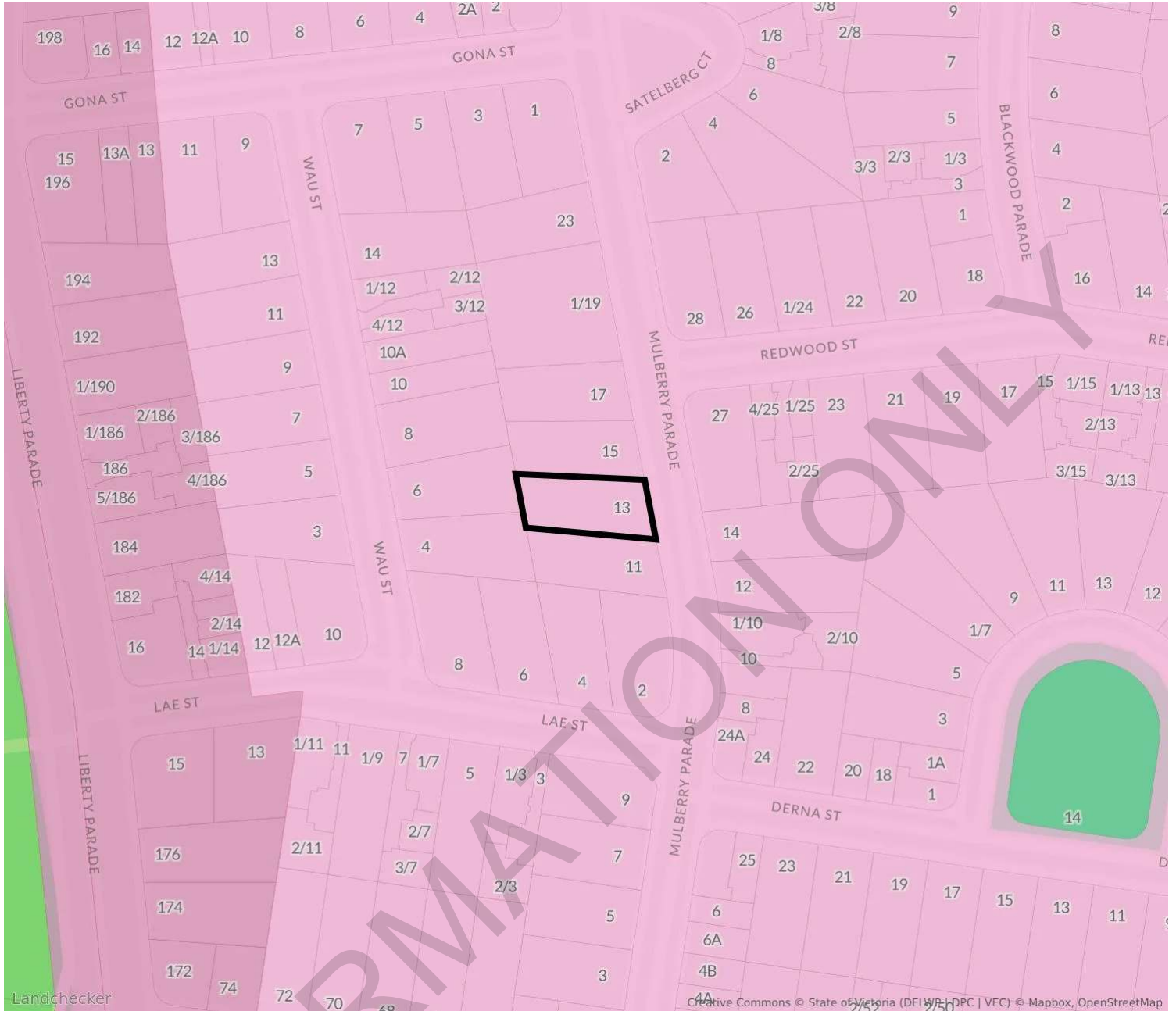

GRZ1 - General Residential Zone - Schedule 1

To implement the Municipal Planning Strategy and the Planning Policy Framework.

To encourage development that is responsive to the neighbourhood character of the area.

To encourage a diversity of housing types and housing growth particularly in locations offering good access to services and transport.

To allow educational, recreational, religious, community and a limited range of other non-residential uses to serve local community needs in appropriate locations.

VPP 32.08 General Residential Zone

None specified.

LPP 32.08 Schedule 1 To Clause 32.08 General Residential Zone

For confirmation and detailed advice about this planning zone, please contact BANYULE council on 03 9457 9808.

Other nearby planning zones

- PCRZ - Public Conservation And Resource Zone
- PPRZ - Public Park And Recreation Zone
- RGZ - Residential Growth Zone

PREMIUM REPORT \$24.90 - Includes:

Visit landchecker.com.au to view plans

 Planning Permits
Approved and Pending

 Planning Scheme Amendments
90 days Proposed and Approved

 Site Dimensions
Approximate Site Dimensions

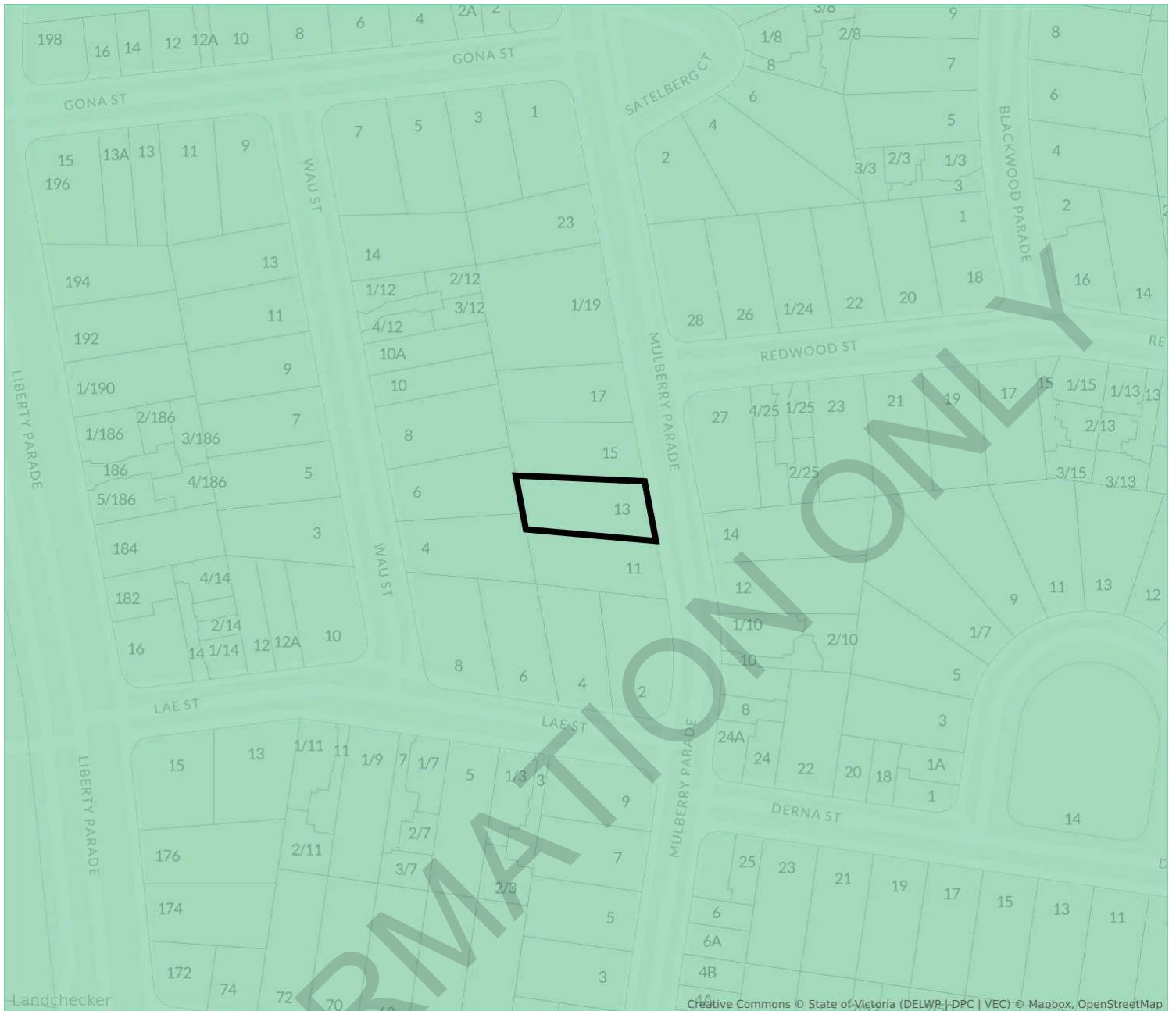

DCPO1 - Development Contributions Plan Overlay - Schedule 1

To implement the Municipal Planning Strategy and the Planning Policy Framework.

To identify areas which require the preparation of a development contributions plan for the purpose of levying contributions for the provision of works, services and facilities before development can commence.

VPP 45.06 Development Contributions Plan Overlay

This Development Contributions Plan (DCP) applies to all new development within the 24 Charge Areas shown on Map 1 to Schedule 1 to Clause 45.06

LPP 45.06 Schedule 1 To Clause 45.06 Development Contributions Plan Overlay

For confirmation and detailed advice about this planning overlay, please contact BANYULE council on 03 9457 9808.

PREMIUM REPORT \$24.90 - Includes:

Visit landchecker.com.au to view plans

 Planning Permits
Approved and Pending

 Planning Scheme Amendments
90 days Proposed and Approved

 Site Dimensions
Approximate Site Dimensions



VPO5 - Vegetation Protection Overlay - Schedule 5

To implement the Municipal Planning Strategy and the Planning Policy Framework.

To protect areas of significant vegetation.

To ensure that development minimises loss of vegetation.

To preserve existing trees and other vegetation.

To recognise vegetation protection areas as locations of special significance, natural beauty, interest and importance.

To maintain and enhance habitat and habitat corridors for indigenous fauna.

To encourage the regeneration of native vegetation.

VPP 42.02 Vegetation Protection Overlay

Banyule’s vegetation and treed streetscapes are one of the most valued characteristics that contribute to the City’s neighbourhood character. Whilst the vegetation cover in much of Banyule’s Garden Suburban and Garden

Court neighbourhoods is noticeably less than other areas of the City, these neighbourhoods do include a significant number of large indigenous, native and exotic trees (Substantial Trees) that are prominent above and around existing dwellings. These Substantial Trees beautify and add natural interest to these residential areas. Banyule’s Garden Court and Garden Suburban neighbourhoods are located between important waterway corridors, natural features and sites of botanical significance. Indigenous, native and exotic Substantial Trees in these neighbourhoods therefore assist in wildlife movement across the City, provide important faunal habitat and assist in the protection of waterways. Substantial Trees feature in the remnant overstorey of Garden Court and Garden Suburban neighbourhoods. These areas contain one or a number of indigenous species, remnant exotic trees, and areas of dense remnant overstorey all with a high degree of naturalness. This

PREMIUM REPORT \$24.90 - Includes:

Visit landchecker.com.au to view plans

 Planning Permits
Approved and Pending

 Planning Scheme Amendments
90 days Proposed and Approved

 Site Dimensions
Approximate Site Dimensions

overstorey is tall vegetation that represents Banyule's natural heritage, and includes species that are rare, threatened or of local, regional or State significance. The generally wider canopy spread and larger structure of Substantial Trees in Garden Court and Garden Suburban neighbourhoods help to build local identity and make a visual contribution to the urban character of a street, surrounding neighbourhood, and landscape including contributing to Banyule's ridgelines which are visible in backdrops and vistas. They also assist in stabilising the local environment through processes including; reducing the severity of temperature increases associated with the 'urban heat island' effect, sequestering harmful pollutants and managing storm water. The significance of Substantial Trees and their incremental removal affects the City in a number of ways. Tree protection and management, together with new and replacement tree planting on properties in Garden Court and Garden Suburban neighbourhoods, can help to safeguard and offset any incremental loss and improve the range of benefits Substantial Trees provide.

[LPP 42.02 Schedule 5 To Clause 42.02 Vegetation Protection Overlay](#)

For confirmation and detailed advice about this planning overlay, please contact BANYULE council on 03 9457 9808.

INFORMATION ONLY

PREMIUM REPORT \$24.90 - Includes:

Visit landchecker.com.au to view plans



Planning Permits
Approved and Pending



Planning Scheme Amendments
90 days Proposed and Approved



Site Dimensions
Approximate Site Dimensions

NEARBY OVERLAYS

13 Mulberry Parade, Heidelberg West Vic 3081

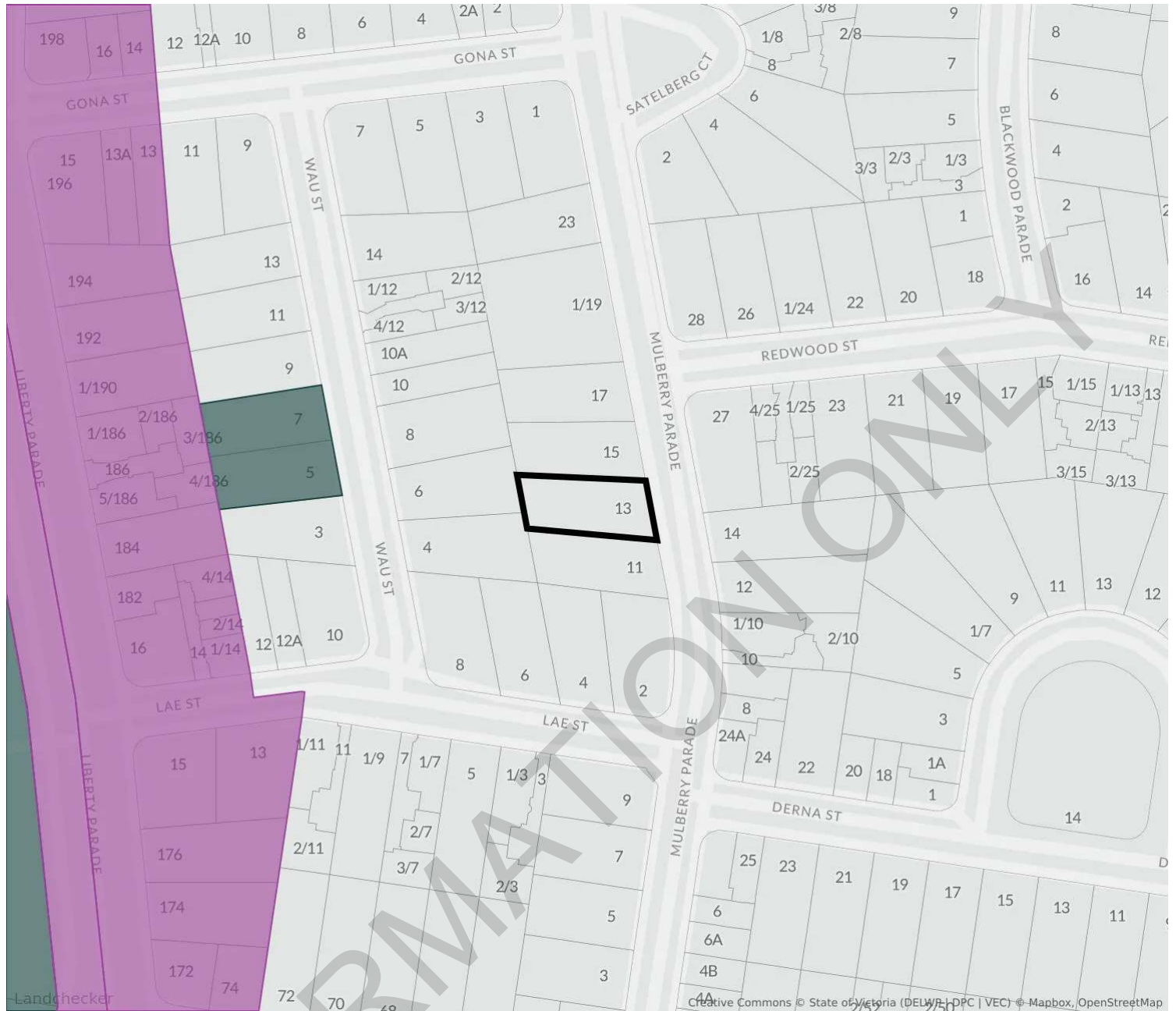

- DDO - Design And Development Overlay**
- ESO - Environmental Significance Overlay**

For confirmation and detailed advice about this planning overlay, please contact BANYULE council on 03 9457 9808.

PREMIUM REPORT \$24.90 - Includes:

Visit landchecker.com.au to view plans

Planning Permits
Approved and Pending

Planning Scheme Amendments
90 days Proposed and Approved

Site Dimensions
Approximate Site Dimensions

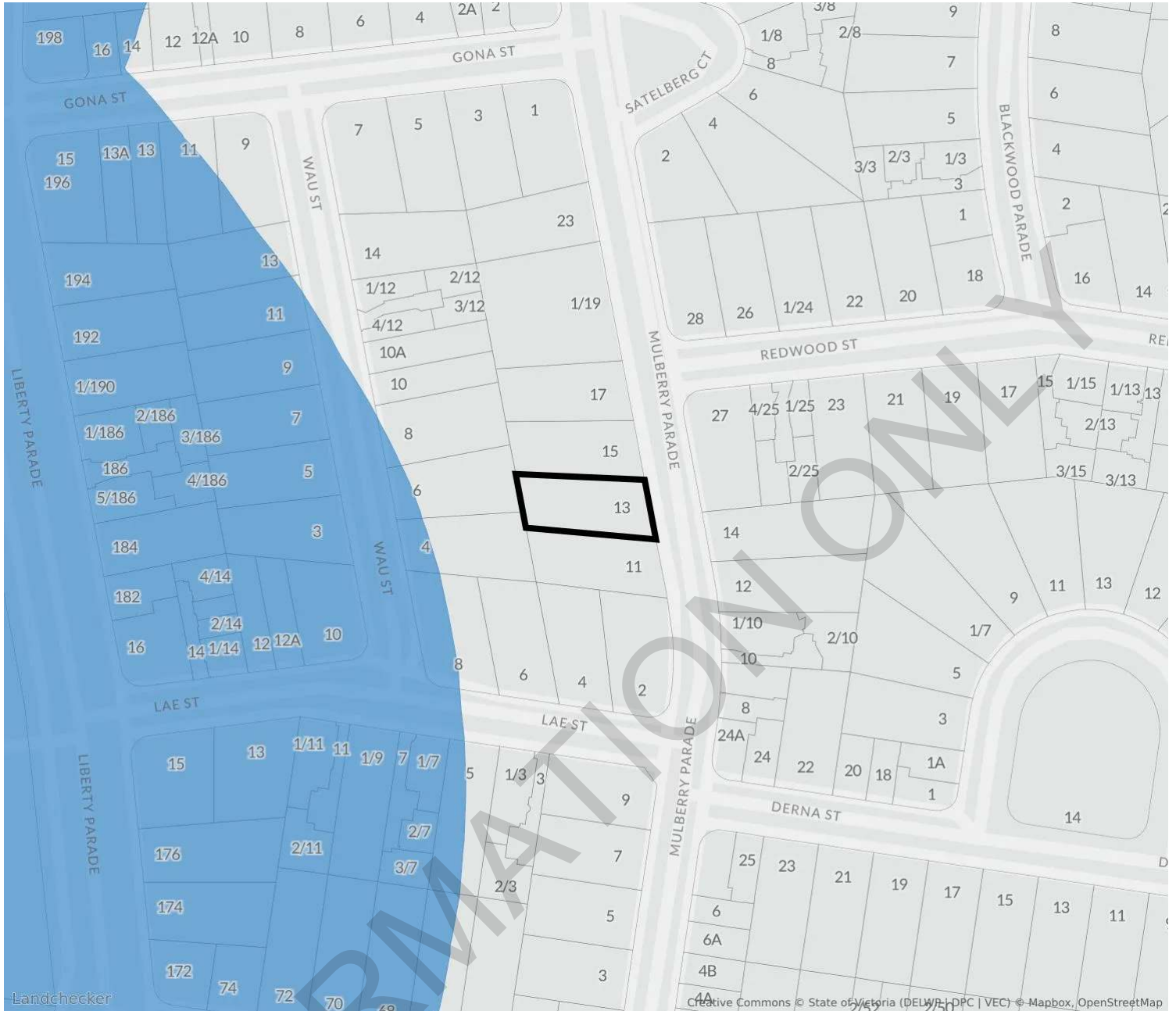

Aboriginal Cultural Heritage Sensitivity

This property is within, or in the vicinity of, one or more areas of cultural heritage sensitivity.

For confirmation and detailed advice about the cultural sensitivity of this property, please contact BANYULE council on 03 9457 9808.

PREMIUM REPORT \$24.90 - Includes:

Visit landchecker.com.au to view plans

 Planning Permits
Approved and Pending

 Planning Scheme Amendments
90 days Proposed and Approved

 Site Dimensions
Approximate Site Dimensions

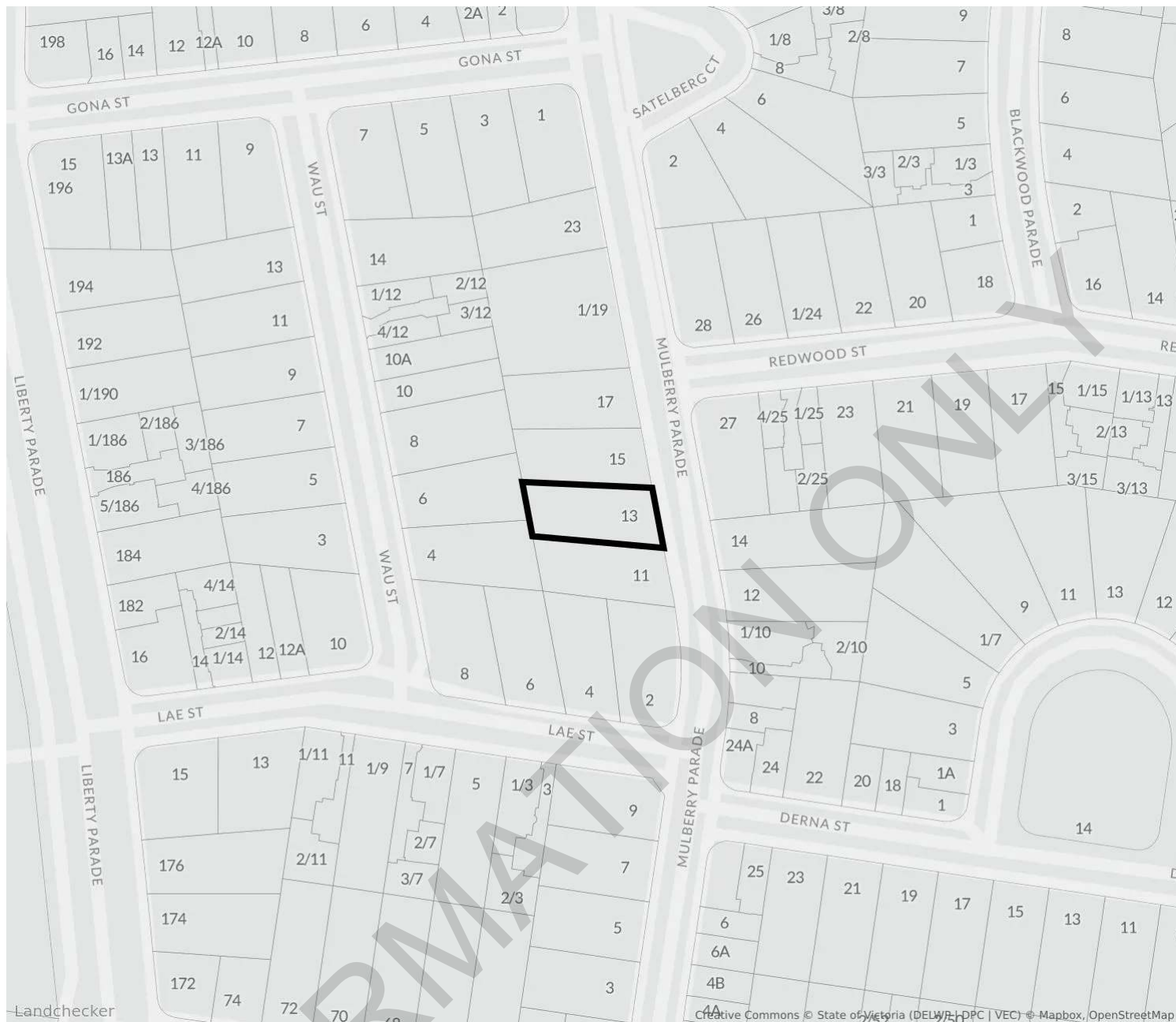

Flood

This property has not been specified as a flood area as per [Landchecker flood sources](#). For further confirmation please reach out to BANYULE to obtain a Flood Certificate for your property.

For confirmation and detailed advice about this flood area, please contact the relevant source authority.

PREMIUM REPORT \$24.90 - Includes:

Visit landchecker.com.au to view plans

 Planning Permits
Approved and Pending

 Planning Scheme Amendments
90 days Proposed and Approved

 Site Dimensions
Approximate Site Dimensions

INFORMATION ONLY

PREMIUM REPORT \$24.90 - Includes:

Visit landchecker.com.au to view plans



Planning Permits
Approved and Pending



Planning Scheme Amendments
90 days Proposed and Approved



Site Dimensions
Approximate Site Dimensions

BUSHFIRE PRONE AREA

13 Mulberry Parade, Heidelberg West Vic 3081

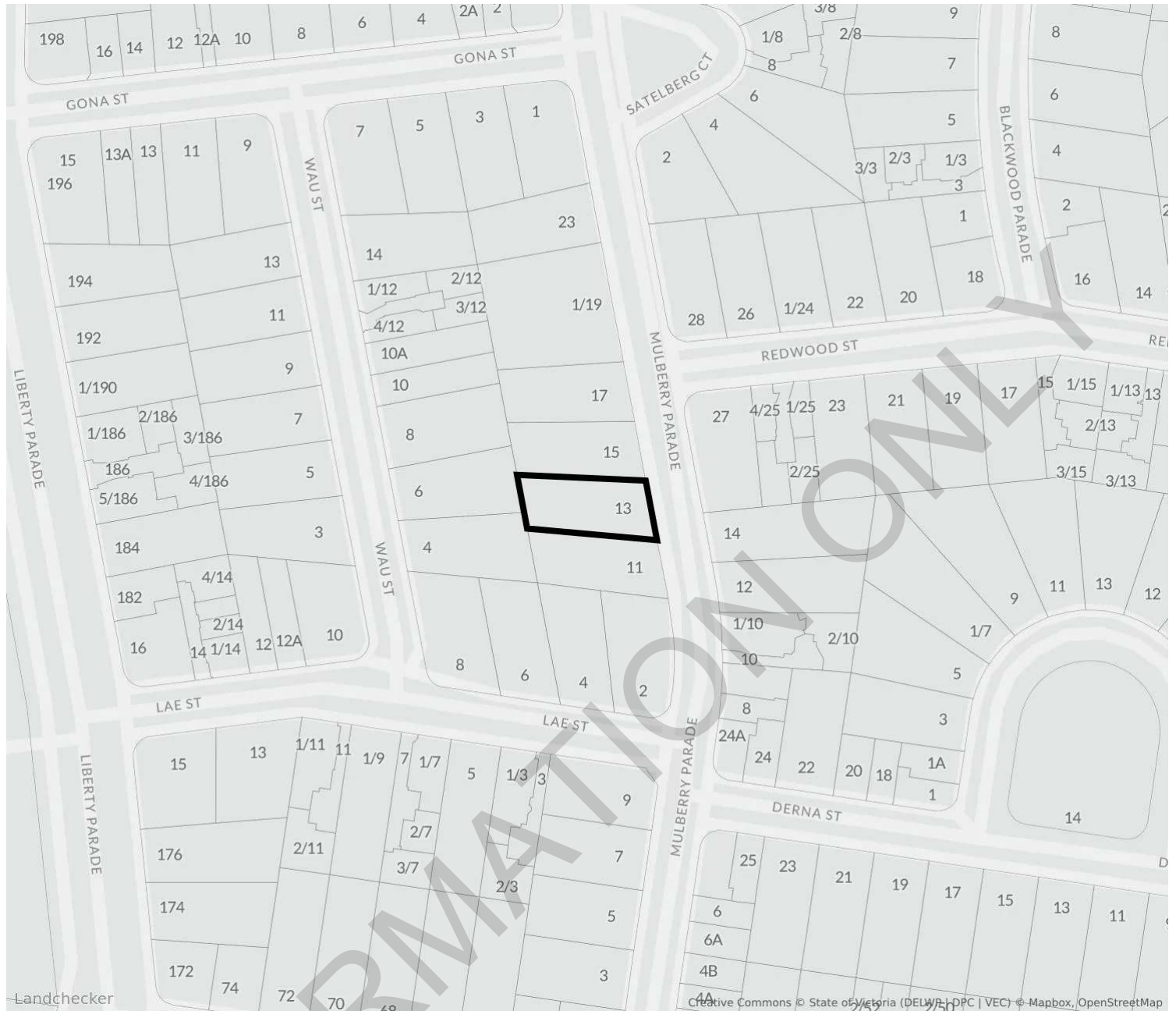

Bushfire Prone Area

This property is not within a zone classified as a bushfire prone area.

For confirmation and detailed advice about this bushfire prone area, please contact the relevant source authority.

PREMIUM REPORT \$24.90 - Includes:

Visit landchecker.com.au to view plans

 Planning Permits
Approved and Pending

 Planning Scheme Amendments
90 days Proposed and Approved

 Site Dimensions
Approximate Site Dimensions

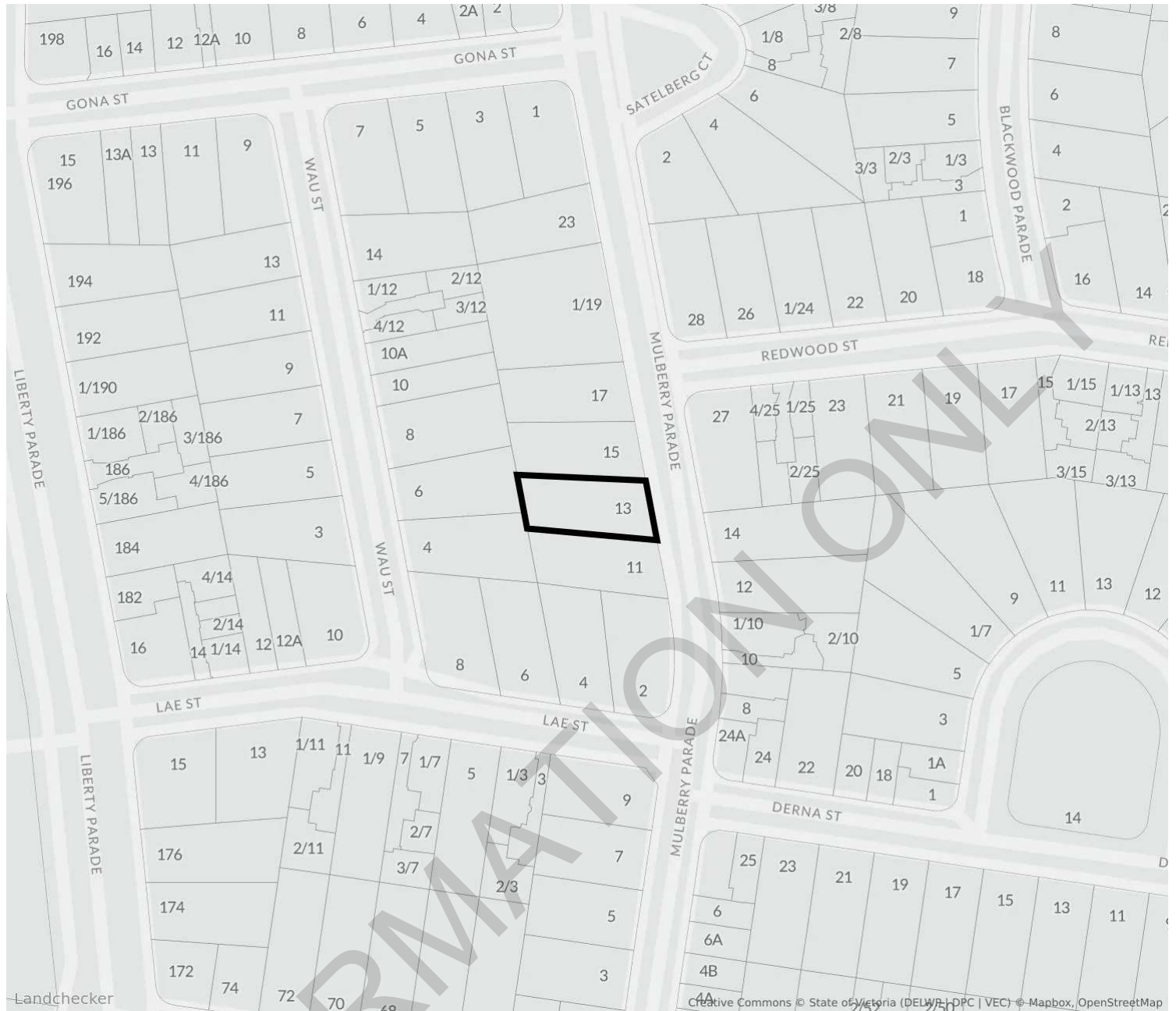

Landslide Prone Area

This property is not within a zone classified as a landslide prone area.

For confirmation and detailed advice about this landslide prone area, please contact the relevant source authority.

PREMIUM REPORT \$24.90 - Includes:

Visit landchecker.com.au to view plans

 Planning Permits
Approved and Pending

 Planning Scheme Amendments
90 days Proposed and Approved

 Site Dimensions
Approximate Site Dimensions

1. Property Report

This Property Report:

- a. is issued subject to the terms and conditions in respect of which Property Reports are issued by Landchecker; and
- b. contains data owned or licensed by our service providers that Landchecker Pty Ltd licences under the terms and conditions in the following links:
 - i. <https://creativecommons.org/licenses/by/4.0/legalcode> in respect of data supplied by the State of Victoria;
 - ii. <https://creativecommons.org/licenses/by/4.0/> respect of census data supplied by the Commonwealth of Australia;
 - iii. <https://www.mapbox.com/tos>, in respect of data supplied by Mapbox Inc.; and
 - iv. <https://www.openstreetmap.org/copyright>, in respect of data supplied by Open Street Maps;
 - v. The information is supplied by Landchecker (ABN 31 607 394 696) on behalf of PropTrack Pty Ltd (ABN 43 127 386 298) [Copyright and Legal Disclaimers about Property Data \(PropTrack\)](#); and
 - vi. <https://creativecommons.org/licenses/by/4.0/> in respect of data supplied by the Australian Curriculum, Assessment and Reporting Authority (ACARA).

2. Use of Property Report

This Property Report is made available for information purposes only. Recipients of this Property Report acknowledge and agree that they may not rely upon the content of this Property Report for any other purposes other than the express purpose for which it is issued and that recipients:

- a. must not use in any manner which is unlawful, offensive, threatening, defamatory, fraudulent, misleading, deceptive or otherwise inappropriate;
- b. must seek their own independent professional advice and seek their own professional advice in respect of the subject matter of this Property Report before acting on or referring to any of the information contained in this Property Report;

- c. acknowledge that this Property Report is provided entirely at recipients' own risk and neither Landchecker nor its service providers take any responsibility or liability for any loss or damage suffered by recipients in reliance on this Property Report; and
- d. acknowledge that this Property Report will not be accurate, complete or reliable.

3. Attributions

State Government Copyright Notice and Disclaimer

The State of Victoria owns the copyright in the Property Sales Data and reproduction of that data in any way without the consent of the State and Victoria will constitute a breach of the Copyright Act 1968 (Cth). The State of Victoria does not warrant the accuracy or completeness of the Property Sales Data and any person using or relying upon such information does so on the basis that the State of Victoria accepts no responsibility or liability whatsoever for any errors, faults, defects or omissions in the information supplied.

Neither Landchecker nor this Property Report are affiliated with, endorsed or authorised by the State of Victoria.

The data in this Property Report may contain property data in respect of an adjacent State. The attribution in respect of the Property Data is only in respect of the property for which the Property Report was obtained. Additional attribution statements for adjoining properties are available in Landchecker's terms of use.

Australian Curriculum Assessment and Reporting Authority

This Property Report contains data that was downloaded from the ACARA website (www.acara.edu.au) (accessed 1 April 2019) and was not modified that is © copyright 2009 to present. ACARA does not:

- a. endorse any product, such as this Property Report, that uses ACARA material; or
- b. make any representations as to the quality of such products.

PREMIUM REPORT \$24.90 - Includes:

Visit landchecker.com.au to view plans



Planning Permits
Approved and Pending



Planning Scheme Amendments
90 days Proposed and Approved



Site Dimensions
Approximate Site Dimensions

18th November 2025

Perfect Choice Conveyancing Services C/- Triconvey
LANDATA

Dear Perfect Choice Conveyancing Services C/- Triconvey,

RE: Application for Water Information Statement

| | |
|------------------------------------|---|
| Property Address: | 13 MULBERRY PARADE HEIDELBERG WEST 3081 |
| Applicant | Perfect Choice Conveyancing Services C/- Triconvey LANDATA |
| Information Statement | 30991418 |
| Conveyancing Account Number | 7959580000 |
| Your Reference | 638708 |

Thank you for your recent application for a Water Information Statement (WIS). We are pleased to provide you the WIS for the above property address. This statement includes:

- Yarra Valley Water Property Information Statement
- Melbourne Water Property Information Statement
- Asset Plan
- Rates Certificate

If you have any questions about Yarra Valley Water information provided, please phone us on **1300 304 688** or email us at the address propertyflow@yvw.com.au. For further information you can also refer to the Yarra Valley Water website at www.yvw.com.au.

Yours sincerely,



Lisa Anelli
GENERAL MANAGER
RETAIL SERVICES

Yarra Valley Water Property Information Statement

| | |
|------------------|---|
| Property Address | 13 MULBERRY PARADE HEIDELBERG WEST 3081 |
|------------------|---|

STATEMENT UNDER SECTION 158 WATER ACT 1989

THE FOLLOWING INFORMATION RELATES TO SECTION 158(3)

Existing sewer mains will be shown on the Asset Plan.

Please note: Unless prior consent has been obtained, the Water Act prohibits:

1. The erection and/or placement of any building, wall, bridge, fence, embankment, filling, material, machinery or other structure over or under any sewer or drain.
2. The connection of any drain or sewer to, or interference with, any sewer, drain or watercourse.

Melbourne Water Property Information Statement

| | |
|------------------|---|
| Property Address | 13 MULBERRY PARADE HEIDELBERG WEST 3081 |
|------------------|---|

STATEMENT UNDER SECTION 158 WATER ACT 1989

THE FOLLOWING INFORMATION RELATES TO SECTION 158(4)

Information available at Melbourne Water indicates that this property is not subject to flooding from Melbourne Water's drainage system, based on a flood level that has a probability of occurrence of 1% in any one year.

Please note: Unless prior consent has been obtained, the Water Act prohibits:

1. The erection and/or placement of any building, wall, bridge, fence, embankment, filling, material, machinery or other structure over or under any sewer or drain.
2. The connection of any drain or sewer to, or interference with, any sewer, drain or watercourse.

If you have any questions regarding Melbourne Water encumbrances or advisory information, please contact Melbourne Water on 9679 7517.

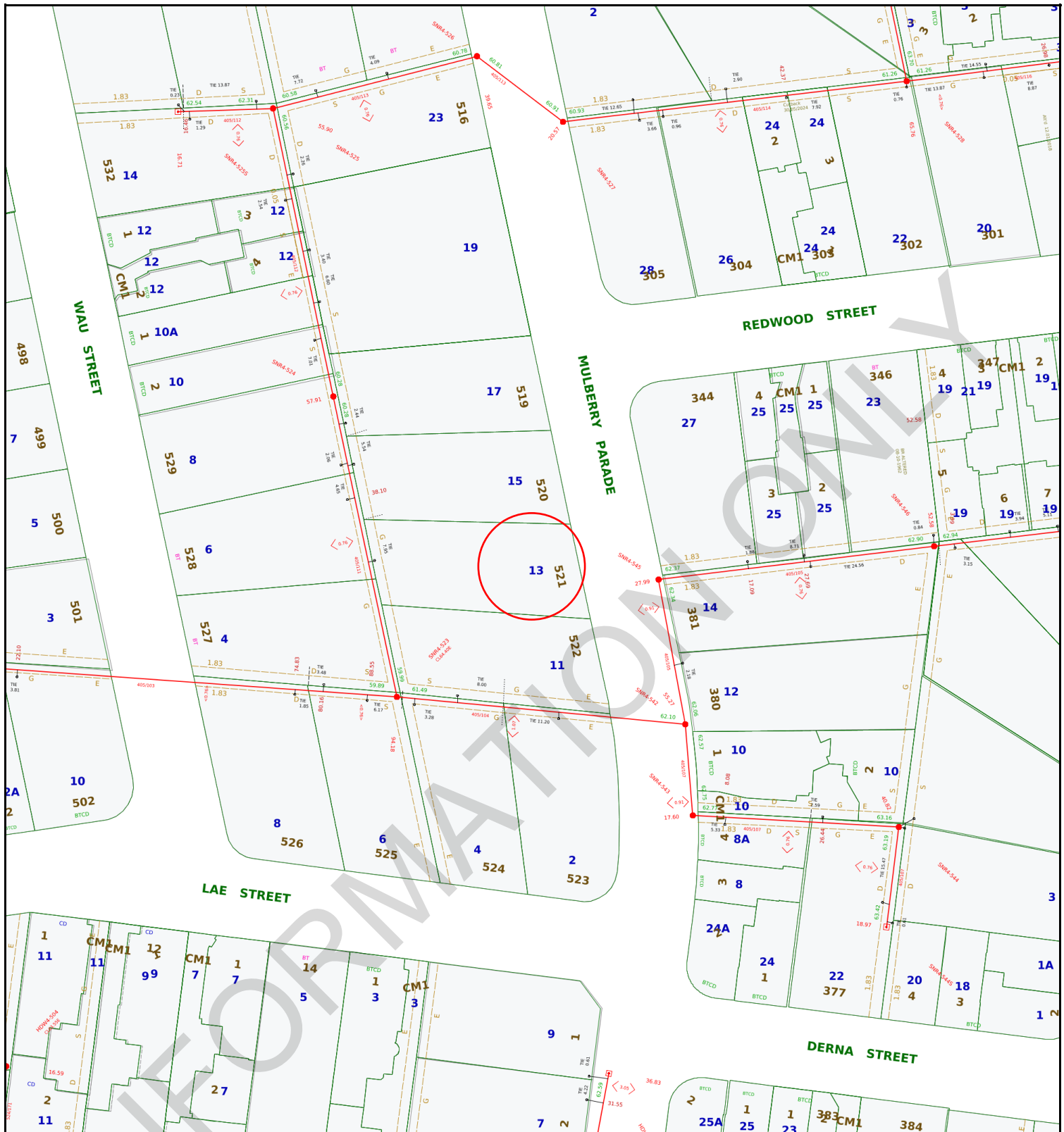















**Yarra Valley Water
Information Statement
Number: 30991418**

| | |
|----------------|---|
| Address | 13 MULBERRY PARADE HEIDELBERG WEST 3081 |
| Date | 18/11/2025 |
| Scale | 1:1000 |



Yarra Valley Water
ABN 93 066 902 501

| | | | |
|-----------------|---|--|--|
| Existing Title |  Access Point Number |  GLV2-42 MW Drainage Channel Centreline |  |
| Proposed Title |  Sewer Manhole |  MW Drainage Underground Centreline |  |
| Easement |  Sewer Pipe Flow |  MW Drainage Manhole |  |
| Existing Sewer |  Sewer Offset |  MW Drainage Natural Waterway |  |
| Abandoned Sewer |  Sewer Branch |  | |

Disclaimer: This information is supplied on the basis Yarra Valley Water Ltd:
 - Does not warrant the accuracy or completeness of the information supplied, including, without limitation, the location of Water and Sewer Assets;
 - Does not accept any liability for loss or damage of any nature, suffered or incurred by the recipient or any other persons relying on this information;
 - Recommends recipients and other persons using this information make their own site investigations and accommodate their works accordingly;

Perfect Choice Conveyancing Services C/- Triconvey
LANDATA
certificates@landata.vic.gov.au

RATES CERTIFICATE

Account No: 3720750000
Rate Certificate No: 30991418

Date of Issue: 18/11/2025
Your Ref: 638708

With reference to your request for details regarding:

| Property Address | Lot & Plan | Property Number | Property Type |
|--|-------------|-----------------|---------------|
| 13 MULBERRY PDE, HEIDELBERG WEST VIC 3081 | 521\LP33339 | 1160723 | Residential |

| Agreement Type | Period | Charges | Outstanding |
|---|--|----------|-------------|
| Residential Water Service Charge | 01-10-2025 to 31-12-2025 | \$21.26 | \$21.26 |
| Residential Water and Sewer Usage Charge <i>Step 1 – 37.840000kL x \$3.43420000 = \$51.38</i> <i>Step 1 – 0.000000kL x \$3.57240000 = \$81.74</i> <i>Step 2 – 6.160000kL x \$4.50590000 = \$10.97</i> <i>Step 2 – 0.000000kL x \$4.68710000 = \$17.46</i> Estimated Average Daily Usage \$1.88 | 27-05-2025 to 21-08-2025 | \$161.55 | \$0.00 |
| Residential Sewer Service Charge | 01-10-2025 to 31-12-2025 | \$122.58 | \$122.58 |
| Parks Fee | 01-10-2025 to 31-12-2025 | \$22.63 | \$22.63 |
| Drainage Fee | 01-10-2025 to 31-12-2025 | \$31.51 | \$31.51 |
| Other Charges: | | | |
| Interest | No interest applicable at this time | | |
| | No further charges applicable to this property | | |
| | Balance Brought Forward | | \$0.00 |
| | Total for This Property | | \$197.98 |



GENERAL MANAGER
RETAIL SERVICES

Note:

- From 1 July 2023, the Parks Fee has been charged quarterly instead of annually.
- From 1 July 2023, for properties that have water and sewer services, the Residential Water and Sewer Usage charge replaces the Residential Water Usage and Residential Sewer Usage charges.
- This statement details all tariffs, charges, and penalties due and payable to Yarra Valley Water as of the date of

this statement and includes tariffs and charges (other than for usage charges yet to be billed) which are due and payable to the end of the current financial quarter.

4. All outstanding debts are due to be paid to Yarra Valley Water at settlement. Any debts that are unpaid at settlement will carry over onto the purchaser's first quarterly account and follow normal credit and collection activities - pursuant to section 275 of the Water Act 1989.

5. If the total due displays a (-\$ cr), this means the account is in credit. Credit amounts will be transferred to the purchaser's account at settlement.

6. Yarra Valley Water provides information in this Rates Certificate relating to waterways and drainage as an agent for Melbourne Water and relating to parks as an agent for Parks Victoria - pursuant to section 158 of the Water Act 1989.

7. The charges on this rates certificate are calculated and valid at the date of issue. To obtain up-to-date financial information, please order a Rates Settlement Statement prior to settlement.

8. From 01/07/2025, Residential Water Usage is billed using the following step pricing system: 266.61 cents per kilolitre for the first 44 kilolitres; 340.78 cents per kilolitre for 44-88 kilolitres and 504.86 cents per kilolitre for anything more than 88 kilolitres. From 1 July 2023, this charge is applicable for properties with water service only.

9. From 01/07/2025, Residential Water and Sewer Usage is billed using the following step pricing system: 357.24 cents per kilolitre for the first 44 kilolitres; 468.71 cents per kilolitre for 44-88 kilolitres and 544.56 cents per kilolitre for anything more than 88 kilolitres. From 1 July 2023, this charge is applicable for residential properties with both water and sewer services.

10. From 01/07/2025, Residential Recycled Water Usage is billed 196.81 cents per kilolitre.

11. From 01/07/2022 up to 30/06/2023, Residential Sewer Usage was calculated using the following equation: Water Usage (kl) x Seasonal Factor x Discharge Factor x Price (/kl) 1.1540 per kilolitre. From 1 July 2023, this charge will no longer be applicable for residential customers with both water and sewer services.

12. The property is a serviced property with respect to all the services, for which charges are listed in the Statement of Fees above.

INFORMATION

To ensure you accurately adjust the settlement amount, we strongly recommend you book a Special Meter Reading:

- Special Meter Readings ensure that actual water use is adjusted for at settlement.
- Without a Special Meter Reading, there is a risk your client's settlement adjustment may not be correct.

Property No: 1160723

Address: 13 MULBERRY PDE, HEIDELBERG WEST VIC 3081

Water Information Statement Number: 30991418

HOW TO PAY



Bill Code: 314567
Ref: 37207500001

**Amount
Paid**

**Date
Paid**

**Receipt
Number**

ROADS PROPERTY CERTIFICATE

The search results are as follows:

Perfect Choice Conveyancing Services C/- Triconvey2 (Reseller)
135 King Street
SYDNEY 2000
AUSTRALIA

Client Reference: 638708

NO PROPOSALS. As at the 17th November 2025, VicRoads has no approved proposals requiring any part of the property described in your application. You are advised to check your local Council planning scheme regarding land use zoning of the property and surrounding area.

This certificate was prepared solely on the basis of the Applicant-supplied address described below, and electronically delivered by LANDATA®.

13 MULBERRY PARADE, HEIDELBERG WEST 3081
CITY OF BANYULE

This certificate is issued in respect of a property identified above. VicRoads expressly disclaim liability for any loss or damage incurred by any person as a result of the Applicant incorrectly identifying the property concerned.

Date of issue: 17th November 2025

Telephone enquiries regarding content of certificate: 13 11 71

[Vicroads Certificate] # 78803583 - 78803583194537 '638708'

Property Clearance Certificate

Land Tax



INFOTRACK / PERFECT CHOICE CONVEYANCING SERVICES

| | |
|------------------------|------------------------|
| Your Reference: | BOWDEN 13 MULBERRY PDE |
| Certificate No: | 94238223 |
| Issue Date: | 18 NOV 2025 |
| Enquiries: | ESYSPROD |

Land Address: 13 MULBERRY PARADE HEIDELBERG WEST VIC 3081

| Land Id | Lot | Plan | Volume | Folio | Tax Payable |
|----------|-----|-------|--------|-------|-------------|
| 10650192 | 521 | 33339 | 8541 | 28 | \$0.00 |

Vendor: JOSEPH BOWDEN
Purchaser: FOR INFORMATION PURPOSES

| Current Land Tax | Year Taxable Value (SV) | Proportional Tax | Penalty/Interest | Total |
|------------------------|-------------------------|------------------|------------------|--------|
| MR JOSEPH ALLAN BOWDEN | 2025 | \$760,000 | \$0.00 | \$0.00 |

Comments: Property is exempt: LTX Principal Place of Residence.

| Current Vacant Residential Land Tax | Year Taxable Value (CIV) | Tax Liability | Penalty/Interest | Total |
|-------------------------------------|--------------------------|---------------|------------------|-------|
|-------------------------------------|--------------------------|---------------|------------------|-------|

Comments:

| Arrears of Land Tax | Year | Proportional Tax | Penalty/Interest | Total |
|---------------------|------|------------------|------------------|-------|
|---------------------|------|------------------|------------------|-------|

This certificate is subject to the notes that appear on the reverse. The applicant should read these notes carefully.

Paul Broderick
Commissioner of State Revenue

| | |
|---|---------------|
| CAPITAL IMPROVED VALUE (CIV): | \$860,000 |
| SITE VALUE (SV): | \$760,000 |
| CURRENT LAND TAX AND VACANT RESIDENTIAL LAND TAX CHARGE: | \$0.00 |

Notes to Certificate - Land Tax

Certificate No: 94238223

Power to issue Certificate

1. Pursuant to section 95AA of the *Taxation Administration Act 1997*, the Commissioner of State Revenue must issue a Property Clearance Certificate (Certificate) to an owner, mortgagee or bona fide purchaser of land who makes an application specifying the land for which the Certificate is sought and pays the application fee.

Amount shown on Certificate

2. The Certificate shows any land tax (including Vacant Residential Land Tax, interest and penalty tax) that is due and unpaid on the land described in the Certificate at the date of issue. In addition, it may show:
 - Land tax that has been assessed but is not yet due,
 - Land tax for the current tax year that has not yet been assessed, and
 - Any other information that the Commissioner sees fit to include, such as the amount of land tax applicable to the land on a single holding basis and other debts with respect to the property payable to the Commissioner.

Land tax is a first charge on land

3. Unpaid land tax (including Vacant Residential Land Tax, interest and penalty tax) is a first charge on the land to which it relates. This means it has priority over any other encumbrances on the land, such as a mortgage, and will continue as a charge even if ownership of the land is transferred. Therefore, a purchaser may become liable for any such unpaid land tax.

Information for the purchaser

4. Pursuant to section 96 of the *Land Tax Act 2005*, if a purchaser of the land described in the Certificate has applied for and obtained a certificate, the amount recoverable from the purchaser by the Commissioner cannot exceed the amount set out in the certificate, described as the "Current Land Tax Charge and Vacant Residential Land Tax Charge" overleaf. A purchaser cannot rely on a Certificate obtained by the vendor.

Information for the vendor

5. Despite the issue of a Certificate, the Commissioner may recover a land tax liability from a vendor, including any amount identified on this Certificate.

Apportioning or passing on land tax to a purchaser

6. A vendor is prohibited from apportioning or passing on land tax including vacant residential land tax, interest and penalty tax to a purchaser under a contract of sale of land entered into on or after 1 January 2024, where the purchase price is less than \$10 million (to be indexed annually from 1 January 2025, as set out on the website for Consumer Affairs Victoria).

General information

7. A Certificate showing no liability for the land does not mean that the land is exempt from land tax. It means that there is nothing to pay at the date of the Certificate.
8. An updated Certificate may be requested free of charge via our website, if:
 - The request is within 90 days of the original Certificate's issue date, and
 - There is no change to the parties involved in the transaction for which the Certificate was originally requested.

For Information Only

LAND TAX CALCULATION BASED ON SINGLE OWNERSHIP

Land Tax = \$3,210.00

Taxable Value = \$760,000

Calculated as \$2,250 plus (\$760,000 - \$600,000) multiplied by 0.600 cents.

VACANT RESIDENTIAL LAND TAX CALCULATION

Vacant Residential Land Tax = \$8,600.00

Taxable Value = \$860,000

Calculated as \$860,000 multiplied by 1.000%.

Land Tax - Payment Options

BPAY



Billers Code: 5249
Ref: 94238223

Telephone & Internet Banking - BPAY®

Contact your bank or financial institution to make this payment from your cheque, savings, debit or transaction account.

www.bpay.com.au

CARD



Ref: 94238223

Visa or Mastercard

Pay via our website or phone 13 21 61.
A card payment fee applies.

sro.vic.gov.au/paylandtax

Property Clearance Certificate

Commercial and Industrial Property Tax



INFOTRACK / PERFECT CHOICE CONVEYANCING SERVICES

| | |
|------------------------|------------------------|
| Your Reference: | Bowden 13 Mulberry Pde |
| Certificate No: | 94238223 |
| Issue Date: | 18 NOV 2025 |
| Enquires: | ESYSPROD |

Land Address: 13 MULBERRY PARADE HEIDELBERG WEST VIC 3081

| Land Id | Lot | Plan | Volume | Folio | Tax Payable |
|----------|-----|-------|--------|-------|-------------|
| 10650192 | 521 | 33339 | 8541 | 28 | \$0.00 |

| AVPCC | Date of entry into reform | Entry interest | Date land becomes CIPT taxable land | Comment |
|-------|---------------------------|----------------|-------------------------------------|--|
| 110 | N/A | N/A | N/A | The AVPCC allocated to the land is not a qualifying use. |

This certificate is subject to the notes found on the reverse of this page. The applicant should read these notes carefully.

Paul Broderick
Commissioner of State Revenue

| | |
|--------------------------------|-----------|
| CAPITAL IMPROVED VALUE: | \$860,000 |
| SITE VALUE: | \$760,000 |
| CURRENT CIPT CHARGE: | \$0.00 |

Notes to Certificate - Commercial and Industrial Property Tax

Certificate No: 94238223

Power to issue Certificate

1. Pursuant to section 95AA of the *Taxation Administration Act 1997*, the Commissioner of State Revenue must issue a Property Clearance Certificate (Certificate) to an owner, mortgagee or bona fide purchaser of land who makes an application specifying the land for which the Certificate is sought and pays the application fee.

Amount shown on Certificate

2. The Certificate shows any commercial and industrial property tax (including interest and penalty tax) that is due and unpaid on the land described in the Certificate at the date of issue.

Australian Valuation Property Classification Code (AVPCC)

3. The Certificate may show one or more AVPCC in respect of land described in the Certificate. The AVPCC shown on the Certificate is the AVPCC allocated to the land in the most recent of the following valuation(s) of the land under the *Valuation of Land Act 1960*:
 - a general valuation of the land;
 - a supplementary valuation of the land returned after the general valuation.
4. The AVPCC(s) shown in respect of land described on the Certificate can be relevant to determine if the land has a qualifying use, within the meaning given by section 4 of the *Commercial and Industrial Property Tax Reform Act 2024* (CIPT Act). Section 4 of the CIPT Act Land provides that land will have a qualifying use if:
 - the land has been allocated one, or more than one, AVPCC in the latest valuation, all of which are in the range 200-499 and/or 600-699 in the Valuation Best Practice Specifications Guidelines (the requisite range);
 - the land has been allocated more than one AVPCC in the latest valuation, one or more of which are inside the requisite range and one or more of which are outside the requisite range, and the land is used solely or primarily for a use described in an AVPCC in the requisite range; or
 - the land is used solely or primarily as eligible student accommodation, within the meaning of section 3 of the CIPT Act.

Commercial and industrial property tax information

5. If the Commissioner has identified that land described in the Certificate is tax reform scheme land within the meaning given by section 3 of the CIPT Act, the Certificate may show in respect of the land:
 - the date on which the land became tax reform scheme land;
 - whether the entry interest (within the meaning given by section 3 of the Duties Act 2000) in relation to the tax reform scheme land was a 100% interest (a whole interest) or an interest of less than 100% (a partial interest); and
 - the date on which the land will become subject to the commercial and industrial property tax.
6. A Certificate that does not show any of the above information in respect of land described in the Certificate does not mean that the land is not tax reform scheme land. It means that the Commissioner has not identified that the land is tax reform scheme land at the date of issue of the Certificate. The Commissioner may identify that the land is tax reform scheme land after the date of issue of the Certificate.

Change of use of tax reform scheme land

7. Pursuant to section 34 of the CIPT Act, an owner of tax reform scheme land must notify the Commissioner of certain changes of use of tax reform scheme land (or part of the land) including if the actual use of the land changes to a use not described in any AVPCC in the range 200-499 and/or 600-699. The notification

must be given to the Commissioner within 30 days of the change of use.

Commercial and industrial property tax is a first charge on land

8. Commercial and industrial property tax (including any interest and penalty tax) is a first charge on the land to which the commercial and industrial property tax is payable. This means it has priority over any other encumbrances on the land, such as a mortgage, and will continue as a charge even if ownership of the land is transferred. Therefore, a purchaser may become liable for any unpaid commercial and industrial property tax.

Information for the purchaser

9. Pursuant to section 27 of the CIPT Act, if a bona fide purchaser for value of the land described in the Certificate applies for and obtains a Certificate in respect of the land, the maximum amount recoverable from the purchaser is the amount set out in the Certificate. A purchaser cannot rely on a Certificate obtained by the vendor.

Information for the vendor

10. Despite the issue of a Certificate, the Commissioner may recover a commercial and industrial property tax liability from a vendor, including any amount identified on this Certificate.

Passing on commercial and industrial property tax to a purchaser

11. A vendor is prohibited from apportioning or passing on commercial and industrial property tax to a purchaser under a contract of sale of land entered into on or after 1 July 2024 where the purchase price is less than \$10 million (to be indexed annually from 1 January 2025, as set out on the website for Consumer Affairs Victoria).

General information

12. Land enters the tax reform scheme if there is an entry transaction, entry consolidation or entry subdivision in respect of the land (within the meaning given to those terms in the CIPT Act). Land generally enters the reform on the date on which an entry transaction occurs in respect of the land (or the first date on which land from which the subject land was derived (by consolidation or subdivision) entered the reform).
13. The Duties Act includes exemptions from duty, in certain circumstances, for an eligible transaction (such as a transfer) of tax reform scheme land that has a qualifying use on the date of the transaction. The exemptions apply differently based on whether the entry interest in relation to the land was a whole interest or a partial interest. For more information, please refer to www.sro.vic.gov.au/CIPT.
14. A Certificate showing no liability for the land does not mean that the land is exempt from commercial and industrial property tax. It means that there is nothing to pay at the date of the Certificate.
15. An updated Certificate may be requested free of charge via our website, if:
 - the request is within 90 days of the original Certificate's issue date, and
 - there is no change to the parties involved in the transaction for which the Certificate was originally requested.

Property Clearance Certificate

Windfall Gains Tax



INFOTRACK / PERFECT CHOICE CONVEYANCING SERVICES

Your Reference: BOWDEN 13 MULBERRY PDE

Certificate No: 94238223

Issue Date: 18 NOV 2025

Land Address: 13 MULBERRY PARADE HEIDELBERG WEST VIC 3081

| Lot | Plan | Volume | Folio |
|-----|-------|--------|-------|
| 521 | 33339 | 8541 | 28 |

Vendor: JOSEPH BOWDEN

Purchaser: FOR INFORMATION PURPOSES

| WGT Property Id | Event ID | Windfall Gains Tax | Deferred Interest | Penalty/Interest | Total |
|-----------------|----------|--------------------|-------------------|------------------|--------|
| | | \$0.00 | \$0.00 | \$0.00 | \$0.00 |

Comments: No windfall gains tax liability identified.

This certificate is subject to the notes that appear on the reverse. The applicant should read these notes carefully.

CURRENT WINDFALL GAINS TAX CHARGE:

\$0.00

Paul Broderick
Commissioner of State Revenue

Notes to Certificate - Windfall Gains Tax

Certificate No: 94238223

Power to issue Certificate

1. Pursuant to section 95AA of the *Taxation Administration Act 1997*, the Commissioner of State Revenue must issue a Property Clearance Certificate (Certificate) to an owner, mortgagee or bona fide purchaser of land who makes an application specifying the land for which the Certificate is sought and pays the application fee.

Amount shown on Certificate

2. The Certificate shows in respect of the land described in the Certificate:
 - Windfall gains tax that is due and unpaid, including any penalty tax and interest
 - Windfall gains tax that is deferred, including any accrued deferral interest
 - Windfall gains tax that has been assessed but is not yet due
 - Windfall gains tax that has not yet been assessed (i.e. a WGT event has occurred that rezones the land but any windfall gains tax on the land is yet to be assessed)
 - Any other information that the Commissioner sees fit to include such as the amount of interest accruing per day in relation to any deferred windfall gains tax.

Windfall gains tax is a first charge on land

3. Pursuant to section 42 of the *Windfall Gains Tax Act 2021*, windfall gains tax, including any accrued interest on a deferral, is a first charge on the land to which it relates. This means it has priority over any other encumbrances on the land, such as a mortgage, and will continue as a charge even if ownership of the land is transferred. Therefore, a purchaser may become liable for any unpaid windfall gains tax.

Information for the purchaser

4. Pursuant to section 42 of the *Windfall Gains Tax Act 2021*, if a bona fide purchaser for value of land applies for and obtains a Certificate in respect of the land, the maximum amount recoverable from the purchaser by the Commissioner is the amount set out in the certificate, described as the "Current Windfall Gains Tax Charge" overleaf.
5. If the certificate states that a windfall gains tax is yet to be assessed, note 4 does not apply.
6. A purchaser cannot rely on a Certificate obtained by the vendor.

Information for the vendor

7. Despite the issue of a Certificate, the Commissioner may recover a windfall gains tax liability from a vendor, including any amount identified on this Certificate.

Passing on windfall gains tax to a purchaser

8. A vendor is prohibited from passing on a windfall gains tax liability to a purchaser where the liability has been assessed under a notice of assessment as at the date of the contract of sale of land or option agreement. This prohibition does not apply to a contract of sale entered into before 1 January 2024, or a contract of sale of land entered into on or after 1 January 2024 pursuant to the exercise of an option granted before 1 January 2024.

General information

9. A Certificate showing no liability for the land does not mean that the land is exempt from windfall gains tax. It means that there is nothing to pay at the date of the Certificate.
10. An updated Certificate may be requested free of charge via our website, if:
 - The request is within 90 days of the original Certificate's issue date, and
 - There is no change to the parties involved in the transaction for which the Certificate was originally requested.
11. Where a windfall gains tax liability has been deferred, interest accrues daily on the deferred liability. The deferred interest shown overleaf is the amount of interest accrued to the date of issue of the certificate.

Windfall Gains Tax - Payment Options

BPAY



Bill Code: 416073
Ref: 94238227

Telephone & Internet Banking - BPAY®

Contact your bank or financial institution to make this payment from your cheque, savings, debit or transaction account.

www.bpay.com.au

CARD



Ref: 94238227

Visa or Mastercard

Pay via our website or phone 13 21 61.
A card payment fee applies.

sro.vic.gov.au/payment-options

Important payment information

Windfall gains tax payments must be made using only these specific payment references.

Using the incorrect references for the different tax components listed on this property clearance certificate will result in misallocated payments.

Land Information Certificate

Section 121 Local Government Act, 2020

Your Reference: 78803583-014-3



Applicant:

Perfect Choice Conveyancing
C/- Triconvey2 (Reseller) via LANDATA
GPO Box 527
MELBOURNE VIC 3001

Issue date: 20/11/2025
Assessment Number: 403337
Certificate Number: 20931

Property Location: 13 Mulberry Parade HEIDELBERG WEST VIC 3081

Title: LOT: 521 LP: 33339 V/F: 8541/028

AVPCC: 110 – Detached Dwelling

Capital Improved Value: \$900,000.00

Site Value: \$760,000.00

Net Annual Value: \$45,000.00

Effective Date: 01/07/2025

Base Date: 01/01/2025

Period: 01/07/2025 – 30/06/2026

This certificate provides information regarding valuation, rates, charges, other money owing and any orders and notices made under the *Local Government Act 2020*, the *Local Government Act 1989*, the *Local Government Act 1958* or under a local law of the Council. This certificate is not required to include information regarding planning, building, health, land fill, land slip, flooding information or service easements. Information regarding these matters may be available from Council or the relevant authority. A fee may be charged for such information.

RATES, CHARGES AND OTHER MONIES:

| | | |
|--|------------|--------------------|
| Rate Arrears to 30/06/2025 | | \$10,000.57 |
| Residential Improved | 01/07/2025 | \$1,556.83 |
| Kerbside Waste Rate | 01/07/2025 | \$228.28 |
| Public Waste Rate | 01/07/2025 | \$104.90 |
| Non Standard 240L Rubbish Surcharge | 01/07/2025 | \$250.00 |
| Non Standard 240L FOGO Surcharge | 01/07/2025 | \$120.00 |
| ESVF - Residential Fixed Charge | 01/07/2025 | \$136.00 |
| ESVF - Residential Variable Charge | 01/07/2025 | \$155.70 |
| Interest to 27/10/2025 | | \$0.00 |
| Other Monies: | | \$0.00 |
| Less Pension Rebate | | -\$316.00 |
| Less Payments | | \$0.00 |
| Less other Adjustments | | \$0.00 |
| Total Due | | \$12,236.28 |
| Additional Monies Owed: Debtor Balance Owing | | \$0.00 |
| Total Rates, Debtors and Special Rates and Charges: | | \$12,236.28 |

NOTE: In accordance with section 175(1) & (2) Local Government Act 1989, a person who becomes the owner of rateable land must pay any rate or charge on the land which is current and any arrears of rates or charges (including any interest on those rates or charges) on the land that are due and payable. **RATES ARE PAYABLE BY 4 INSTALMENTS. OVERDUE AMOUNTS ACCRUE INTEREST ON A DAILY BASIS AT 10.0% P.A applied from the**

date the instalment was due. Instalment due dates are 30 September, 30 November, 28 February and 31 May each year.

2. OUTSTANDING OR POTENTIAL LIABILITY/SUBDIVISIONAL REQUIREMENT:

There is no money owed for works under the **Local Government Act 1989** or the **Local Government Act 1958**.

There is no potential liability for rates under the **Cultural and Recreational Lands Act 1963**.

There is no potential liability for the land to become rateable under section 173 or 174A of the **Local Government Act 1989** unless shown below.

There is no outstanding amount required to be paid for recreational purposes or any transfer of land required to be made to Council for recreational purposes under Section 18 of the **Subdivision Act 1988** or the **Local Government Act 1958**.

There are no notices, orders or agreements on the land that have been served by Council under the **Local Government Act 1958**, the **Local Government Act 1989**, **Local Government Act 2020** or under a local law of the Council, which have a continuing application as at the date of this certificate, unless shown below.

3. OTHER INFORMATION:

A Building Over Easement Indemnity Agreement applies to this land. This agreement specifies owner's responsibilities and must be renewed during the transfer of ownership. Please contact Council's Engineering Services Section on 9490 4222 or enquiries@banyule.vic.gov.au for further details.

4. STORMWATER FLOWS:

This property has been assessed as being subject to overland stormwater flows. Please contact Council's Engineering Services Section on 9490 4222 or enquiries@banyule.vic.gov.au for further details.

5. PAYMENTS:

Rates, Levies and Charges are usually paid at settlement. Council accepts payment via BPAY®.



Biller Code: 404707

Ref: 60000000403337

Telephone & Internet Banking – BPAY Contact your bank or financial institution to make this payment from your cheque, savings, debit, credit card or transaction account. More info: www.bpay.com.au

® Registered to BPAY Pty Ltd ABN 69 079 137 518

6. SWIMMING POOL FENCING:

It is the owner/s responsibility to ensure that their Swimming Pool and or Spa and Safety Barrier is registered with Council. Please contact Banyule Council Building Department on 9433 7777 to confirm if it has been registered and/or when they are required to submit the next Form 23 Certificate of Pool & Spa Barrier Compliance.

7. SPECIAL NOTES:

This certificate is valid for 60 days from the date of issue. Amounts outstanding may vary if payments/adjustments are made after the issue date. It is the responsibility of the applicant to obtain an update prior to settlement.

After the issue of this certificate, Council may be prepared to provide a verbal update of information to the applicant or to a third party upon confirmation of certificate number, regarding the matters disclosed in this certificate, but if it does so, Council accepts no responsibility whatsoever for the accuracy of the verbal information given and no employee of the Council is authorised to bind Council by the giving of such verbal information. Please note that updates will not be provided after the 60 day period has passed where a certificate has been applied for in the preceding rate year.

I hereby certify that as at the date of this certificate the information given is a correct disclosure of the rates, other monies and interest payable to Banyule City Council, together with details of any Notices or Orders on the land pursuant to the Local Government Acts and Local Laws.

Received the sum of \$30.60 being the statutory fee for this certificate.

For further information contact: REVENUE SERVICES 9490 4222.



AUTHORISED OFFICER

In accordance with section 122(1)(b) of the *Local Government Act 2020*, a person who acquires any land in a municipal district must give an acquisition notice to the Chief Executive Officer of the Council of the municipal district in which the land is located within one month. A Notice of Acquisition should be sent to enquiries@banyule.vic.gov.au or via mail to **PO Box 94, GREENSBOROUGH VIC 3088**

INFORMATION ONLY

Due Diligence Checklist



What you need to know before buying a residential property

Before you buy a home, you should be aware of a range of issues that may affect that property and impose restrictions or obligations on you, if you buy it. This checklist aims to help you identify whether any of these issues will affect you. The questions are a starting point only and you may need to seek professional advice to answer some of them. You can find links to organisations and web pages that can help you learn more, by visiting consumer.vic.gov.au/duediligencechecklist.

Urban living

Moving to the inner city?

High density areas are attractive for their entertainment and service areas, but these activities create increased traffic as well as noise and odours from businesses and people. Familiarising yourself with the character of the area will give you a balanced understanding of what to expect.

Is the property subject to an owners corporation?

If the property is part of a subdivision with common property such as driveways or grounds, it may be subject to an owners corporation. You may be required to pay fees and follow rules that restrict what you can do on your property, such as a ban on pet ownership.

Growth areas

Are you moving to a growth area?

You should investigate whether you will be required to pay a growth areas infrastructure contribution.

Flood and fire risk

Does this property experience flooding or bushfire?

Properties are sometimes subject to the risk of fire and flooding due to their location. You should properly investigate these risks and consider their implications for land management, buildings and insurance premiums.

Rural properties

Moving to the country?

If you are looking at property in a rural zone, consider:

- Is the surrounding land use compatible with your lifestyle expectations? Farming can create noise or odour that may be at odds with your expectations of a rural lifestyle.
- Are you considering removing native vegetation? There are regulations which affect your ability to remove native vegetation on private property.
- Do you understand your obligations to manage weeds and pest animals?
- Can you build new dwellings?
- Does the property adjoin crown land, have a water frontage, contain a disused government road, or are there any crown licences associated with the land?

Is there any earth resource activity such as mining in the area?

You may wish to find out more about exploration, mining and quarrying activity on or near the property and consider the issue of petroleum, geothermal and greenhouse gas sequestration permits, leases and licences, extractive industry authorisations and mineral licences.

Soil and groundwater contamination

Has previous land use affected the soil or groundwater?

You should consider whether past activities, including the use of adjacent land, may have caused contamination at the site and whether this may prevent you from doing certain things to or on the land in the future.

Land boundaries

Do you know the exact boundary of the property?

You should compare the measurements shown on the title document with actual fences and buildings on the property, to make sure the boundaries match. If you have concerns about this, you can speak to your lawyer or conveyancer, or commission a site survey to establish property boundaries.

Planning controls

Can you change how the property is used, or the buildings on it?

All land is subject to a planning scheme, run by the local council. How the property is zoned and any overlays that may apply, will determine how the land can be used. This may restrict such things as whether you can build on vacant land or how you can alter or develop the land and its buildings over time.

The local council can give you advice about the planning scheme, as well as details of any other restrictions that may apply, such as design guidelines or bushfire safety design. There may also be restrictions – known as encumbrances – on the property's title, which prevent you from developing the property. You can find out about encumbrances by looking at the section 32 statement.

Are there any proposed or granted planning permits?

The local council can advise you if there are any proposed or issued planning permits for any properties close by. Significant developments in your area may change the local 'character' (predominant style of the area) and may increase noise or traffic near the property.

Safety

Is the building safe to live in?

Building laws are in place to ensure building safety. Professional building inspections can help you assess the property for electrical safety, possible illegal building work, adequate pool or spa fencing and the presence of asbestos, termites, or other potential hazards.

Building permits

Have any buildings or retaining walls on the property been altered, or do you plan to alter them?

There are laws and regulations about how buildings and retaining walls are constructed, which you may wish to investigate to ensure any completed or proposed building work is approved. The local council may be able to give you information about any building permits issued for recent building works done to the property, and what you must do to plan new work. You can also commission a private building surveyor's assessment.

Are any recent building or renovation works covered by insurance?

Ask the vendor if there is any owner-builder insurance or builder's warranty to cover defects in the work done to the property.

Utilities and essential services

Does the property have working connections for water, sewerage, electricity, gas, telephone and internet?

Unconnected services may not be available, or may incur a fee to connect. You may also need to choose from a range of suppliers for these services. This may be particularly important in rural areas where some services are not available.

Buyers' rights

Do you know your rights when buying a property?

The contract of sale and section 32 statement contain important information about the property, so you should request to see these and read them thoroughly. Many people engage a lawyer or conveyancer to help them understand the contracts and ensure the sale goes through correctly. If you intend to hire a professional, you should consider speaking to them before you commit to the sale. There are also important rules about the way private sales and auctions are conducted. These may include a cooling-off period and specific rights associated with 'off the plan' sales. The important thing to remember is that, as the buyer, you have rights