

Contract for the sale and purchase of land 2022 edition

TERM	MEANING OF TERM	NSW DAN:
vendor's agent	Stone Real Estate Ettalong Beach 4/49 The Esplanade, Ettalong Beach NSW 2257	Phone: 02 4369 6000 Ref: Christel Renton
co-agent		
vendor	Marcello Totaro and Tommaso Totaro 41 Salisbury Road, Stanmore, NSW 2048 and 2 Oleander Court, Peakhurst, NSW 2210	
vendor's solicitor	Tonkin Drysdale Partners 79 Blackwall Road, Woy Woy NSW 2256 PO Box 40, Woy Woy NSW 2256	Phone: 02 4341 2355 Email: info@tdplegal.com.au Fax: 02 4344 1420 Ref: PDT:SP:2231536
date for completion land (address, plan details and title reference)	42nd day after the contract date 372 Ocean View Road, Ettalong Beach, New South Wales 2257 Registered Plan: Lot 9 Plan DP 24978 Folio Identifier 9/24978	(clause 15)
improvements	<input type="checkbox"/> VACANT POSSESSION <input checked="" type="checkbox"/> subject to existing tenancies <input checked="" type="checkbox"/> HOUSE <input type="checkbox"/> garage <input type="checkbox"/> carport <input type="checkbox"/> home unit <input type="checkbox"/> carspace <input type="checkbox"/> storage space <input type="checkbox"/> none <input checked="" type="checkbox"/> other: Cabin	
attached copies	<input checked="" type="checkbox"/> documents in the List of Documents as marked or as numbered: <input type="checkbox"/> other documents:	

A real estate agent is permitted by legislation to fill up the items in this box in a sale of residential property.

inclusions	<input checked="" type="checkbox"/> air conditioning	<input checked="" type="checkbox"/> clothes line	<input checked="" type="checkbox"/> fixed floor coverings	<input checked="" type="checkbox"/> range hood
	<input checked="" type="checkbox"/> blinds	<input checked="" type="checkbox"/> curtains	<input checked="" type="checkbox"/> insect screens	<input type="checkbox"/> solar panels
	<input checked="" type="checkbox"/> built-in wardrobes	<input checked="" type="checkbox"/> dishwasher	<input checked="" type="checkbox"/> light fittings	<input checked="" type="checkbox"/> stove
	<input checked="" type="checkbox"/> ceiling fans	<input type="checkbox"/> EV charger	<input type="checkbox"/> pool equipment	<input checked="" type="checkbox"/> TV antenna
	<input checked="" type="checkbox"/> other: garden shed			
exclusions				
purchaser				
purchaser's solicitor				
price				
deposit	_____	(10% of the price, unless otherwise stated)		
balance				
contract date	(if not stated, the date this contract was made)			

Where there is more than one purchaser JOINT TENANTS
 tenants in common in unequal shares, specify:

GST AMOUNT (optional) The price includes GST of: \$
 buyer's agent

Note: Clause 20.15 provides "Where this contract provides for choices, a choice in BLOCK CAPITALS applies unless a different choice is marked."

SIGNING PAGE

<p>VENDOR</p> <p>Signed by</p> <p>_____</p> <p>Vendor</p> <p>_____</p> <p>Vendor</p>	<p>PURCHASER</p> <p>Signed by</p> <p>_____</p> <p>Purchaser</p> <p>_____</p> <p>Purchaser</p>
<p>VENDOR (COMPANY)</p> <p>Signed by in accordance with s127(1) of the Corporations Act 2001 by the authorised person(s) whose signature(s) appear(s) below:</p> <p>_____</p> <p>Signature of authorised person</p> <p>_____</p> <p>Signature of authorised person</p> <p>_____</p> <p>Name of authorised person</p> <p>_____</p> <p>Name of authorised person</p> <p>_____</p> <p>Office held</p> <p>_____</p> <p>Office held</p>	<p>PURCHASER (COMPANY)</p> <p>Signed by in accordance with s127(1) of the Corporations Act 2001 by the authorised person(s) whose signature(s) appear(s) below:</p> <p>_____</p> <p>Signature of authorised person</p> <p>_____</p> <p>Signature of authorised person</p> <p>_____</p> <p>Name of authorised person</p> <p>_____</p> <p>Name of authorised person</p> <p>_____</p> <p>Office held</p> <p>_____</p> <p>Office held</p>

Choices

- Vendor agrees to accept a **deposit-bond** NO yes
- Nominated Electronic Lodgment Network (ELN)** (clause 4) PEXA
-
- Manual transaction** (clause 30) NO yes
(if yes, vendor must provide further details, including any applicable exemption, in the space below):

Tax information (the parties promise this is correct as far as each party is aware)

- Land tax** is adjustable NO yes
- GST:** Taxable supply NO yes in full yes to an extent
- Margin scheme will be used in making the taxable supply NO yes

This sale is not a taxable supply because (one or more of the following may apply) the sale is:

- not made in the course or furtherance of an enterprise that the vendor carries on (section 9-5(b))
- by a vendor who is neither registered nor required to be registered for GST (section 9-5(d))
- GST-free because the sale is the supply of a going concern under section 38-325
- GST-free because the sale is subdivided farm land or farm land supplied for farming under Subdivision 38-O
- input taxed because the sale is of eligible residential premises (sections 40-65, 40-75(2) and 195-1)

- Purchaser must make an **GSTRW payment** NO yes (if yes, vendor must provide details)
(GST residential withholding payment)

If the details below are not fully completed at the contract date, the vendor must provide all these details in a separate notice at least 7 days before the date for completion.

GSTRW payment (GST residential withholding payment) – details

Frequently the supplier will be the vendor. However, sometimes further information will be required as to which entity is liable for GST, for example, if the supplier is a partnership, a trust, part of a GST group or a participant in a GST joint venture.

Supplier's name:

Supplier's ABN:

Supplier's GST branch number (if applicable):

Supplier's business address:

Supplier's representative:

Supplier's contact phone number:

Supplier's proportion of **GSTRW payment**:

If more than one supplier, provide the above details for each supplier.

Amount purchaser must pay – price multiplied by the **GSTRW rate** (residential withholding rate):

Amount must be paid: AT COMPLETION at another time (specify):

Is any of the consideration not expressed as an amount in money? NO yes

If "yes", the GST inclusive market value of the non-monetary consideration: \$

Other details (including those required by regulation or the ATO forms):

List of Documents

<p>General</p> <ul style="list-style-type: none"> <input checked="" type="checkbox"/> 1 property certificate for the land <input checked="" type="checkbox"/> 2 plan of the land <input type="checkbox"/> 3 unregistered plan of the land <input type="checkbox"/> 4 plan of land to be subdivided <input type="checkbox"/> 5 document that is to be lodged with a relevant plan <input checked="" type="checkbox"/> 6 section 10.7(2) planning certificate under Environmental Planning and Assessment Act 1979 <input checked="" type="checkbox"/> 7 additional information included in that certificate under section 10.7(5) <input checked="" type="checkbox"/> 8 sewerage infrastructure location diagram (service location diagram) <input checked="" type="checkbox"/> 9 sewer lines location diagram (sewerage service diagram) <input checked="" type="checkbox"/> 10 document that created or may have created an easement, profit à prendre, restriction on use or positive covenant disclosed in this contract <input type="checkbox"/> 11 <i>planning agreement</i> <input type="checkbox"/> 12 section 88G certificate (positive covenant) <input type="checkbox"/> 13 survey report <input type="checkbox"/> 14 building information certificate or building certificate given under <i>legislation</i> <input type="checkbox"/> 15 occupation certificate <input checked="" type="checkbox"/> 16 lease (with every relevant memorandum or variation) <input type="checkbox"/> 17 other document relevant to tenancies <input type="checkbox"/> 18 licence benefiting the land <input type="checkbox"/> 19 old system document <input type="checkbox"/> 20 Crown purchase statement of account <input type="checkbox"/> 21 building management statement <input checked="" type="checkbox"/> 22 form of requisitions <input type="checkbox"/> 23 <i>clearance certificate</i> <input type="checkbox"/> 24 land tax certificate <p>Home Building Act 1989</p> <ul style="list-style-type: none"> <input type="checkbox"/> 25 insurance certificate <input type="checkbox"/> 26 brochure or warning <input type="checkbox"/> 27 evidence of alternative indemnity cover <p>Swimming Pools Act 1992</p> <ul style="list-style-type: none"> <input type="checkbox"/> 28 certificate of compliance <input type="checkbox"/> 29 evidence of registration <input type="checkbox"/> 30 relevant occupation certificate <input type="checkbox"/> 31 certificate of non-compliance <input type="checkbox"/> 32 detailed reasons of non-compliance 	<p>Strata or community title (clause 23 of the contract)</p> <ul style="list-style-type: none"> <input type="checkbox"/> 33 property certificate for strata common property <input type="checkbox"/> 34 plan creating strata common property <input type="checkbox"/> 35 strata by-laws <input type="checkbox"/> 36 strata development contract or statement <input type="checkbox"/> 37 strata management statement <input type="checkbox"/> 38 strata renewal proposal <input type="checkbox"/> 39 strata renewal plan <input type="checkbox"/> 40 leasehold strata - lease of lot and common property <input type="checkbox"/> 41 property certificate for neighbourhood property <input type="checkbox"/> 42 plan creating neighbourhood property <input type="checkbox"/> 43 neighbourhood development contract <input type="checkbox"/> 44 neighbourhood management statement <input type="checkbox"/> 45 property certificate for precinct property <input type="checkbox"/> 46 plan creating precinct property <input type="checkbox"/> 47 precinct development contract <input type="checkbox"/> 48 precinct management statement <input type="checkbox"/> 49 property certificate for community property <input type="checkbox"/> 50 plan creating community property <input type="checkbox"/> 51 community development contract <input type="checkbox"/> 52 community management statement <input type="checkbox"/> 53 document disclosing a change of by-laws <input type="checkbox"/> 54 document disclosing a change in a development or management contract or statement <input type="checkbox"/> 55 document disclosing a change in boundaries <input type="checkbox"/> 56 information certificate under Strata Schemes Management Act 2015 <input type="checkbox"/> 57 information certificate under Community Land Management Act 2021 <input type="checkbox"/> 58 disclosure statement - off the plan contract <input type="checkbox"/> 59 other document relevant to the off the plan contract <p>Other</p> <ul style="list-style-type: none"> <input checked="" type="checkbox"/> 60 Development Approval
--	--

HOLDER OF STRATA OR COMMUNITY SCHEME RECORDS – Name, address, email address and telephone number

IMPORTANT NOTICE TO VENDORS AND PURCHASERS

Before signing this contract you should ensure that you understand your rights and obligations, some of which are not written in this contract but are implied by law.

WARNING—SMOKE ALARMS

The owners of certain types of buildings and strata lots must have smoke alarms, or in certain cases heat alarms, installed in the building or lot in accordance with regulations under the *Environmental Planning and Assessment Act 1979*. It is an offence not to comply. It is also an offence to remove or interfere with a smoke alarm or heat alarm. Penalties apply.

WARNING—LOOSE-FILL ASBESTOS INSULATION

Before purchasing land that includes residential premises, within the meaning of the *Home Building Act 1989*, Part 8, Division 1A, built before 1985, a purchaser is strongly advised to consider the possibility that the premises may contain loose-fill asbestos insulation, within the meaning of the *Home Building Act 1989*, Part 8, Division 1A. In particular, a purchaser should—

- (a) search the Register required to be maintained under the *Home Building Act 1989*, Part 8, Division 1A, and
- (b) ask the relevant local council whether it holds records showing that the residential premises contain loose-fill asbestos insulation.

For further information about loose-fill asbestos insulation, including areas in which residential premises have been identified as containing loose-fill asbestos insulation, contact NSW Fair Trading.

Cooling off period (purchaser's rights)

- 1 This is the statement required by the *Conveyancing Act 1919*, section 66X. This statement applies to a contract for the sale of residential property.
- 2 **EXCEPT** in the circumstances listed in paragraph 3, the purchaser may rescind the contract before 5pm on—
 - (a) for an off the plan contract—the tenth business day after the day on which the contract was made, or
 - (b) in any other case—the fifth business day after the day on which the contract was made.
- 3 There is **NO COOLING OFF PERIOD**—
 - (a) if, at or before the time the contract is made, the purchaser gives to the vendor, or the vendor's solicitor or agent, a certificate that complies with the Act, section 66W, or
 - (b) if the property is sold by public auction, or
 - (c) if the contract is made on the same day as the property was offered for sale by public auction but passed in, or
 - (d) if the contract is made in consequence of the exercise of an option to purchase the property, other than an option that is void under the Act, section 66ZG.
- 4 A purchaser exercising the right to cool off by rescinding the contract forfeits 0.25% of the purchase price of the property to the vendor.
- 5 The vendor is entitled to recover the forfeited amount from an amount paid by the purchaser as a deposit under the contract. The purchaser is entitled to a refund of any balance.

DISPUTES

If you get into a dispute with the other party, the Law Society and Real Estate Institute encourage you to use informal procedures such as negotiation, independent expert appraisal, the Law Society Conveyancing Dispute Resolution Scheme or mediation (for example mediation under the Law Society Mediation Program).

AUCTIONS

Regulations made under the Property and Stock Agents Act 2002 prescribe a number of conditions applying to sales by auction.

WARNINGS

1. **Various Acts of Parliament and other matters can affect the rights of the parties to this contract. Some important matters are actions, claims, decisions, licences, notices, orders, proposals or rights of way involving:**

APA Group Australian Taxation Office Council County Council Department of Planning and Environment Department of Primary Industries Electricity and gas Land and Housing Corporation Local Land Services	NSW Department of Education NSW Fair Trading Owner of adjoining land Privacy Public Works Advisory Subsidence Advisory NSW Telecommunications Transport for NSW Water, sewerage or drainage authority
---	--

If you think that any of these matters affects the property, tell your solicitor.
2. **A lease may be affected by the Agricultural Tenancies Act 1990, the Residential Tenancies Act 2010 or the Retail Leases Act 1994.**
3. **If any purchase money is owing to the Crown, it will become payable before obtaining consent, or if no consent is needed, when the transfer is registered.**
4. **If a consent to transfer is required under legislation, see clause 27 as to the obligations of the parties.**
5. **The vendor should continue the vendor's insurance until completion. If the vendor wants to give the purchaser possession before completion, the vendor should first ask the insurer to confirm this will not affect the insurance.**
6. **Most purchasers will have to pay transfer duty (and, sometimes, if the purchaser is not an Australian citizen, surcharge purchaser duty) on this contract. Some purchasers may be eligible to choose to pay first home buyer choice property tax instead of transfer duty. If a payment is not made on time, interest and penalties may be incurred.**
7. **If the purchaser agrees to the release of deposit, the purchaser's right to recover the deposit may stand behind the rights of others (for example the vendor's mortgagee).**
8. **The purchaser should arrange insurance as appropriate.**
9. **Some transactions involving personal property may be affected by the Personal Property Securities Act 2009.**
10. **A purchaser should be satisfied that finance will be available at the time of completing the purchase.**
11. **Where the market value of the property is at or above a legislated amount, the purchaser may have to comply with a foreign resident capital gains withholding payment obligation (even if the vendor is not a foreign resident). If so, this will affect the amount available to the vendor on completion.**
12. **Purchasers of some residential properties may have to withhold part of the purchase price to be credited towards the GST liability of the vendor. If so, this will also affect the amount available to the vendor. More information is available from the ATO.**

The vendor sells and the purchaser buys the *property* for the price under these provisions instead of Schedule 3 Conveyancing Act 1919, subject to any *legislation* that cannot be excluded.

1 Definitions (a term in italics is a defined term)

1.1	In this contract, these terms (in any form) mean –	
	<i>adjustment date</i>	the earlier of the giving of possession to the purchaser or completion;
	<i>adjustment figures</i>	details of the adjustments to be made to the price under clause 14;
	<i>authorised Subscriber</i>	a <i>Subscriber</i> (not being a <i>party's solicitor</i>) named in a notice served by a <i>party</i> as being authorised for the purposes of clause 20.6.8;
	<i>bank</i>	the Reserve Bank of Australia or an authorised deposit-taking institution which is a bank, a building society or a credit union;
	<i>business day</i>	any day except a bank or public holiday throughout NSW or a Saturday or Sunday;
	<i>cheque</i>	a cheque that is not postdated or stale;
	<i>clearance certificate</i>	a certificate within the meaning of s14-220 of Schedule 1 to the <i>TA Act</i> , that covers one or more days falling within the period from and including the contract date to completion;
	<i>completion time</i>	the time of day at which completion is to occur;
	<i>conveyancing rules</i>	the rules made under s12E of the Real Property Act 1900;
	<i>deposit-bond</i>	a deposit bond or guarantee with each of the following approved by the vendor – <ul style="list-style-type: none"> • the issuer; • the expiry date (if any); and • the amount;
	<i>depositholder</i>	vendor's agent (or if no vendor's agent is named in this contract, the vendor's <i>solicitor</i> , or if no vendor's <i>solicitor</i> is named in this contract, the buyer's agent);
	<i>discharging mortgagee</i>	any discharging mortgagee, chargee, covenant chargee or caveator whose provision of a <i>Digitally Signed</i> discharge of mortgage, discharge of charge or withdrawal of caveat is required in order for unencumbered title to the <i>property</i> to be transferred to the purchaser;
	<i>document of title</i>	document relevant to the title or the passing of title;
	<i>ECNL</i>	the Electronic Conveyancing National Law (NSW);
	<i>electronic document</i>	a dealing as defined in the Real Property Act 1900 which may be created and <i>Digitally Signed</i> in an <i>Electronic Workspace</i> ;
	<i>electronic transaction</i>	a <i>Conveyancing Transaction</i> to be conducted for the <i>parties</i> by their legal representatives as <i>Subscribers</i> using an <i>ELN</i> and in accordance with the <i>ECNL</i> and the <i>participation rules</i> ;
	<i>electronic transfer</i>	a transfer of land under the Real Property Act 1900 for the <i>property</i> to be prepared and <i>Digitally Signed</i> in the <i>Electronic Workspace</i> established for the purposes of the <i>parties' Conveyancing Transaction</i> ;
	<i>FRCGW percentage</i>	the percentage mentioned in s14-200(3)(a) of Schedule 1 to the <i>TA Act</i> (12.5% as at 1 July 2017);
	<i>FRCGW remittance</i>	a remittance which the purchaser must make under s14-200 of Schedule 1 to the <i>TA Act</i> ; being the lesser of the <i>FRCGW percentage</i> of the price (inclusive of GST, if any) and the amount specified in a <i>variation served by a party</i> ;
	<i>GST Act</i>	A New Tax System (Goods and Services Tax) Act 1999;
	<i>GST rate</i>	the rate mentioned in s4 of A New Tax System (Goods and Services Tax Imposition - General) Act 1999 (10% as at 1 July 2000);
	<i>GSTRW payment</i>	a payment which the purchaser must make under s14-250 of Schedule 1 to the <i>TA Act</i> (the price multiplied by the <i>GSTRW rate</i>);
	<i>GSTRW rate</i>	the rate determined under ss14-250(6), (8) or (9) of Schedule 1 to the <i>TA Act</i> (as at 1 July 2018, usually 7% of the price if the margin scheme applies, 1/11 th if not);
	<i>incoming mortgagee</i>	any mortgagee who is to provide finance to the purchaser on the security of the <i>property</i> and to enable the purchaser to pay the whole or part of the price;
	<i>legislation</i>	an Act or a by-law, ordinance, regulation or rule made under an Act;
	<i>manual transaction</i>	a <i>Conveyancing Transaction</i> in which a dealing forming part of the <i>Lodgment Case</i> at or following completion cannot be <i>Digitally Signed</i> ;
	<i>normally</i>	subject to any other provision of this contract;
	<i>participation rules</i>	the participation rules as determined by the <i>ECNL</i> ;
	<i>party</i>	each of the vendor and the purchaser;
	<i>property</i>	the land, the improvements, all fixtures and the inclusions, but not the exclusions;
	<i>planning agreement</i>	a valid voluntary agreement within the meaning of s7.4 of the Environmental Planning and Assessment Act 1979 entered into in relation to the <i>property</i> ;
	<i>populate</i>	to complete data fields in the <i>Electronic Workspace</i> ;

<i>requisition</i>	an objection, question or requisition (but the term does not include a claim);
<i>rescind</i>	rescind this contract from the beginning;
<i>serve</i>	serve in writing on the other <i>party</i> ;
<i>settlement cheque</i>	an unendorsed <i>cheque</i> made payable to the person to be paid and – <ul style="list-style-type: none"> • issued by a <i>bank</i> and drawn on itself; or • if authorised in writing by the vendor or the vendor's <i>solicitor</i>, some other <i>cheque</i>;
<i>solicitor</i>	in relation to a <i>party</i> , the <i>party's</i> solicitor or licensed conveyancer named in this contract or in a notice <i>served</i> by the <i>party</i> ;
<i>TA Act</i>	Taxation Administration Act 1953;
<i>terminate</i>	terminate this contract for breach;
<i>title data</i>	the details of the title to the <i>property</i> made available to the <i>Electronic Workspace</i> by the <i>Land Registry</i> ;
<i>variation</i>	a variation made under s14-235 of Schedule 1 to the <i>TA Act</i> ;
<i>within</i>	in relation to a period, at any time before or during the period; and
<i>work order</i>	a valid direction, notice or order that requires work to be done or money to be spent on or in relation to the <i>property</i> or any adjoining footpath or road (but the term does not include a notice under s22E of the Swimming Pools Act 1992 or clause 22 of the Swimming Pools Regulation 2018).

- 1.2 Words and phrases used in this contract (italicised and in Title Case, such as *Conveyancing Transaction*, *Digitally Signed*, *Electronic Workspace*, *ELN*, *ELNO*, *Land Registry*, *Lodgment Case* and *Subscriber*) have the meanings given in the *participation rules*.

2 Deposit and other payments before completion

- 2.1 The purchaser must pay the deposit to the *depositholder* as stakeholder.
- 2.2 *Normally*, the purchaser must pay the deposit on the making of this contract, and this time is essential.
- 2.3 If this contract requires the purchaser to pay any of the deposit by a later time, that time is also essential.
- 2.4 The purchaser can pay any of the deposit by –
- 2.4.1 giving cash (up to \$2,000) to the *depositholder*;
- 2.4.2 unconditionally giving a *cheque* to the *depositholder* or to the vendor, vendor's agent or vendor's *solicitor* for sending to the *depositholder*, or
- 2.4.3 electronic funds transfer to the *depositholder's* nominated account and, if requested by the vendor or the *depositholder*, providing evidence of that transfer.
- 2.5 The vendor can *terminate* if –
- 2.5.1 any of the deposit is not paid on time;
- 2.5.2 a *cheque* for any of the deposit is not honoured on presentation; or
- 2.5.3 a payment under clause 2.4.3 is not received in the *depositholder's* nominated account by 5.00 pm on the third *business day* after the time for payment.
- This right to *terminate* is lost as soon as the deposit is paid in full.
- 2.6 If the vendor accepts a *deposit-bond* for the deposit, clauses 2.1 to 2.5 do not apply.
- 2.7 If the vendor accepts a *deposit-bond* for part of the deposit, clauses 2.1 to 2.5 apply only to the balance.
- 2.8 If any of the deposit or of the balance of the price is paid before completion to the vendor or as the vendor directs, it is a charge on the land in favour of the purchaser until *termination* by the vendor or completion, subject to any existing right.
- 2.9 If each *party* tells the *depositholder* that the deposit is to be invested, the *depositholder* is to invest the deposit (at the risk of the *party* who becomes entitled to it) with a *bank*, in an interest-bearing account in NSW, payable at call, with interest to be reinvested, and pay the interest to the *parties* equally, after deduction of all proper government taxes and financial institution charges and other charges.

3 Deposit-bond

- 3.1 This clause applies only if the vendor accepts a *deposit-bond* for the deposit (or part of it).
- 3.2 The purchaser must provide the *deposit-bond* to the vendor's *solicitor* (or if no *solicitor* the *depositholder*) at or before the making of this contract and this time is essential.
- 3.3 If the *deposit-bond* has an expiry date and completion does not occur by the date which is 14 days before the expiry date, the purchaser must *serve* a replacement *deposit-bond* at least 7 days before the expiry date. The time for service is essential.
- 3.4 The vendor must approve a replacement *deposit-bond* if –
- 3.4.1 it is from the same issuer and for the same amount as the earlier *deposit-bond*; and
- 3.4.2 it has an expiry date at least three months after its date of issue.
- 3.5 A breach of clauses 3.2 or 3.3 entitles the vendor to *terminate*. The right to *terminate* is lost as soon as –
- 3.5.1 the purchaser *serves* a replacement *deposit-bond*; or
- 3.5.2 the deposit is paid in full under clause 2.
- 3.6 Clauses 3.3 and 3.4 can operate more than once.

- 3.7 If the purchaser *serves* a replacement *deposit-bond*, the vendor must *serve* the earlier *deposit-bond*.
- 3.8 The amount of any *deposit-bond* does not form part of the price for the purposes of clause 16.5.
- 3.9 The vendor must give the purchaser any original *deposit-bond* –
- 3.9.1 on completion; or
- 3.9.2 if this contract is *rescinded*.
- 3.10 If this contract is *terminated* by the vendor –
- 3.10.1 *normally*, the vendor can immediately demand payment from the issuer of the *deposit-bond*; or
- 3.10.2 if the purchaser *serves* prior to *termination* a notice disputing the vendor's right to *terminate*, the vendor must forward any original *deposit-bond* (or its proceeds if called up) to the *depositholder* as stakeholder.
- 3.11 If this contract is *terminated* by the purchaser –
- 3.11.1 *normally*, the vendor must give the purchaser any original *deposit-bond*; or
- 3.11.2 if the vendor *serves* prior to *termination* a notice disputing the purchaser's right to *terminate*, the vendor must forward any original *deposit-bond* (or its proceeds if called up) to the *depositholder* as stakeholder.
- 4 Electronic transaction**
- 4.1 This *Conveyancing Transaction* is to be conducted as an *electronic transaction* unless –
- 4.1.1 the contract says this transaction is a *manual transaction*, giving the reason, or
- 4.1.2 a *party serves* a notice stating why the transaction is a *manual transaction*, in which case the *parties* do not have to complete earlier than 14 days after *service* of the notice, and clause 21.3 does not apply to this provision, and in both cases clause 30 applies.
- 4.2 If, because of clause 4.1.2, this *Conveyancing Transaction* is to be conducted as a *manual transaction* –
- 4.2.1 each *party* must –
- bear equally any disbursements or fees; and
 - otherwise bear that *party's* own costs;
- incurred because this *Conveyancing Transaction* was to be conducted as an *electronic transaction*; and
- 4.2.2 if a *party* has paid all of a disbursement or fee which, by reason of this clause, is to be borne equally by the *parties*, that amount must be adjusted under clause 14.
- 4.3 The *parties* must conduct the *electronic transaction* –
- 4.3.1 in accordance with the *participation rules* and the *ECNL*; and
- 4.3.2 using the nominated *ELN*, unless the *parties* otherwise agree. This clause 4.3.2 does not prevent a *party* using an *ELN* which can *interoperate* with the nominated *ELN*.
- 4.4 A *party* must pay the fees and charges payable by that *party* to the *ELNO* and the *Land Registry*.
- 4.5 *Normally*, the vendor must *within* 7 days of the contract date create and *populate* an *Electronic Workspace* with *title data* and the date for completion, and invite the purchaser to the *Electronic Workspace*.
- 4.6 If the vendor has not created an *Electronic Workspace* in accordance with clause 4.5, the purchaser may create and *populate* an *Electronic Workspace* and, if it does so, the purchaser must invite the vendor to the *Electronic Workspace*.
- 4.7 The *parties* must, as applicable to their role in the *Conveyancing Transaction* and the steps taken under clauses 4.5 or 4.6 –
- 4.7.1 promptly join the *Electronic Workspace* after receipt of an invitation;
- 4.7.2 create and *populate* an *electronic transfer*;
- 4.7.3 invite any *discharging mortgagee* or *incoming mortgagee* to join the *Electronic Workspace*; and
- 4.7.4 *populate* the *Electronic Workspace* with a nominated *completion time*.
- 4.8 If the transferee in the *electronic transfer* is not the purchaser, the purchaser must give the vendor a direction signed by the purchaser personally for that transfer.
- 4.9 The vendor can require the purchaser to include a covenant or easement in the *electronic transfer* only if this contract contains the wording of the proposed covenant or easement, and a description of the land burdened and benefited.
- 4.10 If the purchaser must make a *GSTRW payment* or an *FRCGW remittance*, the purchaser must *populate* the *Electronic Workspace* with the payment details for the *GSTRW payment* or *FRCGW remittance* payable to the Deputy Commissioner of Taxation at least 2 *business days* before the date for completion.
- 4.11 Before completion, the *parties* must ensure that –
- 4.11.1 all *electronic documents* which a *party* must *Digitally Sign* to complete the *electronic transaction* are *populated* and *Digitally Signed*;
- 4.11.2 all certifications required by the *ECNL* are properly given; and
- 4.11.3 they do everything else in the *Electronic Workspace* which that *party* must do to enable the *electronic transaction* to proceed to completion.
- 4.12 If the computer systems of any of the *Land Registry*, the *ELNO*, Revenue NSW or the Reserve Bank of Australia are inoperative for any reason at the *completion time* agreed by the *parties*, a failure to complete this contract for that reason is not a default under this contract on the part of either *party*.

- 4.13 If the computer systems of the *Land Registry* are inoperative for any reason at the *completion time* agreed by the *parties*, and the *parties* choose that financial settlement is to occur despite this, then on financial settlement occurring –
- 4.13.1 all *electronic documents Digitally Signed* by the vendor and any discharge of mortgage, withdrawal of caveat or other *electronic document* forming part of the *Lodgment Case* for the *electronic transaction* are taken to have been unconditionally and irrevocably delivered to the purchaser or the purchaser's mortgagee at the time of financial settlement together with the right to deal with the land; and
- 4.13.2 the vendor is taken to have no legal or equitable interest in the *property*.
- 4.14 If the *parties* do not agree about the delivery before completion of one or more documents or things that cannot be delivered through the *Electronic Workspace*, the *party* required to deliver the documents or things –
- 4.14.1 holds them on completion in escrow for the benefit of; and
- 4.14.2 must immediately after completion deliver the documents or things to, or as directed by; the *party* entitled to them.

5 Requisitions

- 5.1 If a form of *requisitions* is attached to this contract, the purchaser is taken to have made those *requisitions*.
- 5.2 If the purchaser is or becomes entitled to make any other *requisition*, the purchaser can make it only by *servicing* it –
- 5.2.1 if it arises out of this contract or it is a general question about the *property* or title - *within 21 days* after the contract date;
- 5.2.2 if it arises out of anything *served* by the vendor - *within 21 days* after the later of the contract date and that *service*; and
- 5.2.3 in any other case - *within* a reasonable time.

6 Error or misdescription

- 6.1 *Normally*, the purchaser can (but only before completion) claim compensation for an error or misdescription in this contract (as to the *property*, the title or anything else and whether substantial or not).
- 6.2 This clause applies even if the purchaser did not take notice of or rely on anything in this contract containing or giving rise to the error or misdescription.
- 6.3 However, this clause does not apply to the extent the purchaser knows the true position.

7 Claims by purchaser

- Normally*, the purchaser can make a claim (including a claim under clause 6) before completion only by *servicing* it with a statement of the amount claimed, and if the purchaser makes one or more claims before completion –
- 7.1 the vendor can *rescind* if in the case of claims that are not claims for delay –
- 7.1.1 the total amount claimed exceeds 5% of the price;
- 7.1.2 the vendor *serves* notice of intention to *rescind*; and
- 7.1.3 the purchaser does not *serve* notice waiving the claims *within 14 days* after that *service*; and
- 7.2 if the vendor does not *rescind*, the *parties* must complete and if this contract is completed –
- 7.2.1 the lesser of the total amount claimed and 10% of the price must be paid out of the price to and held by the *depositholder* until the claims are finalised or lapse;
- 7.2.2 the amount held is to be invested in accordance with clause 2.9;
- 7.2.3 the claims must be finalised by an arbitrator appointed by the *parties* or, if an appointment is not made *within 1 month* of completion, by an arbitrator appointed by the President of the Law Society at the request of a *party* (in the latter case the *parties* are bound by the terms of the Conveyancing Arbitration Rules approved by the Law Society as at the date of the appointment);
- 7.2.4 the purchaser is not entitled, in respect of the claims, to more than the total amount claimed and the costs of the purchaser;
- 7.2.5 net interest on the amount held must be paid to the *parties* in the same proportion as the amount held is paid; and
- 7.2.6 if the *parties* do not appoint an arbitrator and neither *party* requests the President to appoint an arbitrator *within 3 months* after completion, the claims lapse and the amount belongs to the vendor.

8 Vendor's rights and obligations

- 8.1 The vendor can *rescind* if –
- 8.1.1 the vendor is, on reasonable grounds, unable or unwilling to comply with a *requisition*;
- 8.1.2 the vendor *serves* a notice of intention to *rescind* that specifies the *requisition* and those grounds; and
- 8.1.3 the purchaser does not *serve* a notice waiving the *requisition within 14 days* after that *service*.

- 8.2 If the vendor does not comply with this contract (or a notice under or relating to it) in an essential respect, the purchaser can *terminate* by *-serving* a notice. After the *termination* –
- 8.2.1 the purchaser can recover the deposit and any other money paid by the purchaser under this contract;
- 8.2.2 the purchaser can sue the vendor to recover damages for breach of contract; and
- 8.2.3 if the purchaser has been in possession a *party* can claim for a reasonable adjustment.
- 9 Purchaser's default**
- If the purchaser does not comply with this contract (or a notice under or relating to it) in an essential respect, the vendor can *terminate* by *-serving* a notice. After the *termination* the vendor can –
- 9.1 keep or recover the deposit (to a maximum of 10% of the price);
- 9.2 hold any other money paid by the purchaser under this contract as security for anything recoverable under this clause –
- 9.2.1 for 12 months after the *termination*; or
- 9.2.2 if the vendor commences proceedings under this clause *within* 12 months, until those proceedings are concluded; and
- 9.3 sue the purchaser either –
- 9.3.1 where the vendor has resold the *property* under a contract made *within* 12 months after the *termination*, to recover –
- the deficiency on resale (with credit for any of the deposit kept or recovered and after allowance for any capital gains tax or goods and services tax payable on anything recovered under this clause); and
 - the reasonable costs and expenses arising out of the purchaser's non-compliance with this contract or the notice and of resale and any attempted resale; or
- 9.3.2 to recover damages for breach of contract.
- 10 Restrictions on rights of purchaser**
- 10.1 The purchaser cannot make a claim or *requisition* or *rescind* or *terminate* in respect of –
- 10.1.1 the ownership or location of any fence as defined in the Dividing Fences Act 1991;
- 10.1.2 a service for the *property* being a joint service or passing through another property, or any service for another property passing through the *property* ('service' includes air, communication, drainage, electricity, garbage, gas, oil, radio, sewerage, telephone, television or water service);
- 10.1.3 a wall being or not being a party wall in any sense of that term or the *property* being affected by an easement for support or not having the benefit of an easement for support;
- 10.1.4 any change in the *property* due to fair wear and tear before completion;
- 10.1.5 a promise, representation or statement about this contract, the *property* or the title, not set out or referred to in this contract;
- 10.1.6 a condition, exception, reservation or restriction in a Crown grant;
- 10.1.7 the existence of any authority or licence to explore or prospect for gas, minerals or petroleum;
- 10.1.8 any easement or restriction on use the substance of either of which is disclosed in this contract or any non-compliance with the easement or restriction on use; or
- 10.1.9 anything the substance of which is disclosed in this contract (except a caveat, charge, mortgage, priority notice or writ).
- 10.2 The purchaser cannot *rescind* or *terminate* only because of a defect in title to or quality of the inclusions.
- 10.3 *Normally*, the purchaser cannot make a claim or *requisition* or *rescind* or *terminate* or require the vendor to change the nature of the title disclosed in this contract (for example, to remove a caution evidencing qualified title, or to lodge a plan of survey as regards limited title).
- 11 Compliance with work orders**
- 11.1 *Normally*, the vendor must by completion comply with a *work order* made on or before the contract date and if this contract is completed the purchaser must comply with any other *work order*.
- 11.2 If the purchaser complies with a *work order*, and this contract is *rescinded* or *terminated*, the vendor must pay the expense of compliance to the purchaser.
- 12 Certificates and inspections**
- The vendor must do everything reasonable to enable the purchaser, subject to the rights of any tenant –
- 12.1 to have the *property* inspected to obtain any certificate or report reasonably required;
- 12.2 to apply (if necessary in the name of the vendor) for –
- 12.2.1 any certificate that can be given in respect of the *property* under *legislation*; or
- 12.2.2 a copy of any approval, certificate, consent, direction, notice or order in respect of the *property* given under *legislation*, even if given after the contract date; and
- 12.3 to make 1 inspection of the *property* in the 3 days before a time appointed for completion.

13 Goods and services tax (GST)

- 13.1 Terms used in this clause which are not defined elsewhere in this contract and have a defined meaning in the *GST Act* have the same meaning in this clause.
- 13.2 *Normally*, if a *party* must pay the price or any other amount to the other *party* under this contract, GST is not to be added to the price or amount.
- 13.3 If under this contract a *party* must make an adjustment or payment for an expense of another party or pay an expense payable by or to a third party (for example, under clauses 14 or 20.7) –
- 13.3.1 the *party* must adjust or pay on completion any GST added to or included in the expense; but
- 13.3.2 the amount of the expense must be reduced to the extent the party receiving the adjustment or payment (or the representative member of a GST group of which that party is a member) is entitled to an input tax credit for the expense; and
- 13.3.3 if the adjustment or payment under this contract is consideration for a taxable supply, an amount for GST must be added at the *GST rate*.
- 13.4 If this contract says this sale is the supply of a going concern –
- 13.4.1 the *parties* agree the supply of the *property* is a supply of a going concern;
- 13.4.2 the vendor must, between the contract date and completion, carry on the enterprise conducted on the land in a proper and business-like way;
- 13.4.3 if the purchaser is not registered by the date for completion, the *parties* must complete and the purchaser must pay on completion, in addition to the price, an amount being the price multiplied by the *GST rate* ("the retention sum"). The retention sum is to be held by the *depositholder* and dealt with as follows –
- if *within* 3 months of completion the purchaser *serves* a letter from the Australian Taxation Office stating the purchaser is registered with a date of effect of registration on or before completion, the *depositholder* is to pay the retention sum to the purchaser; but
 - if the purchaser does not *serve* that letter *within* 3 months of completion, the *depositholder* is to pay the retention sum to the vendor; and
- 13.4.4 if the vendor, despite clause 13.4.1, *serves* a letter from the Australian Taxation Office stating the vendor has to pay GST on the supply, the purchaser must pay to the vendor on demand the amount of GST assessed.
- 13.5 *Normally*, the vendor promises the margin scheme will not apply to the supply of the *property*.
- 13.6 If this contract says the margin scheme is to apply in making the taxable supply, the *parties* agree that the margin scheme is to apply to the sale of the *property*.
- 13.7 If this contract says the sale is not a taxable supply –
- 13.7.1 the purchaser promises that the *property* will not be used and represents that the purchaser does not intend the *property* (or any part of the *property*) to be used in a way that could make the sale a taxable supply to any extent; and
- 13.7.2 the purchaser must pay the vendor on completion in addition to the price an amount calculated by multiplying the price by the *GST rate* if this sale is a taxable supply to any extent because of –
- a breach of clause 13.7.1; or
 - something else known to the purchaser but not the vendor.
- 13.8 If this contract says this sale is a taxable supply in full and does not say the margin scheme applies to the *property*, the vendor must pay the purchaser on completion an amount of one-eleventh of the price if –
- 13.8.1 this sale is not a taxable supply in full; or
- 13.8.2 the margin scheme applies to the *property* (or any part of the *property*).
- 13.9 If this contract says this sale is a taxable supply to an extent –
- 13.9.1 clause 13.7.1 does not apply to any part of the *property* which is identified as being a taxable supply; and
- 13.9.2 the payments mentioned in clauses 13.7 and 13.8 are to be recalculated by multiplying the relevant payment by the proportion of the price which represents the value of that part of the *property* to which the clause applies (the proportion to be expressed as a number between 0 and 1). Any evidence of value must be obtained at the expense of the vendor.
- 13.10 *Normally*, on completion the vendor must give the recipient of the supply a tax invoice for any taxable supply by the vendor by or under this contract.
- 13.11 The vendor does not have to give the purchaser a tax invoice if the margin scheme applies to a taxable supply.
- 13.12 If the vendor is liable for GST on rents or profits due to issuing an invoice or receiving consideration before completion, any adjustment of those amounts must exclude an amount equal to the vendor's GST liability.
- 13.13 If the vendor *serves* details of a *GSTRW payment* which the purchaser must make, the purchaser does not have to complete earlier than 5 *business days* after that *service* and clause 21.3 does not apply to this provision.
- 13.14 If the purchaser must make a *GSTRW payment* the purchaser must, at least 2 *business days* before the date for completion, *serve* evidence of submission of a *GSTRW payment* notification form to the Australian Taxation Office by the purchaser or, if a direction under either clause 4.8 or clause 30.4 has been given, by the transferee named in the transfer the subject of that direction.

14 Adjustments

- 14.1 *Normally*, the vendor is entitled to the rents and profits and will be liable for all rates, water, sewerage and drainage service and usage charges, land tax, levies and all other periodic outgoings up to and including the *adjustment date* after which the purchaser will be entitled and liable.
- 14.2 The *parties* must make any necessary adjustment on completion, and –
- 14.2.1 the purchaser must provide the vendor with *adjustment figures* at least 2 *business days* before the date for completion; and
- 14.2.2 the vendor must confirm the *adjustment figures* at least 1 *business day* before the date for completion.
- 14.3 If an amount that is adjustable under this contract has been reduced under *legislation*, the *parties* must on completion adjust the reduced amount.
- 14.4 The *parties* must not adjust surcharge land tax (as defined in the Land Tax Act 1956) but must adjust any other land tax for the year current at the *adjustment date* –
- 14.4.1 only if land tax has been paid or is payable for the year (whether by the vendor or by a predecessor in title) and this contract says that land tax is adjustable;
- 14.4.2 by adjusting the amount that would have been payable if at the start of the year –
- the person who owned the land owned no other land;
 - the land was not subject to a special trust or owned by a non-concessional company; and
 - if the land (or part of it) had no separate taxable value, by calculating its separate taxable value on a proportional area basis.
- 14.5 The *parties* must not adjust any first home buyer choice property tax.
- 14.6 If any other amount that is adjustable under this contract relates partly to the land and partly to other land, the *parties* must adjust it on a proportional area basis.
- 14.7 If on completion the last bill for a water, sewerage or drainage usage charge is for a period ending before the *adjustment date*, the vendor is liable for an amount calculated by dividing the bill by the number of days in the period then multiplying by the number of unbilled days up to and including the *adjustment date*.
- 14.8 The vendor is liable for any amount recoverable for work started on or before the contract date on the *property* or any adjoining footpath or road.

15 Date for completion

The *parties* must complete by the date for completion and, if they do not, a *party* can *serve* a notice to complete if that *party* is otherwise entitled to do so.

16 Completion**• Vendor**

- 16.1 *Normally*, on completion the vendor must cause the legal title to the *property* (being the estate disclosed in this contract) to pass to the purchaser free of any charge, mortgage or other interest, subject to any necessary registration.
- 16.2 The legal title to the *property* does not pass before completion.
- 16.3 If the vendor gives the purchaser a document (other than the transfer) that needs to be lodged for registration, the vendor must pay the lodgment fee to the purchaser.
- 16.4 If a *party serves* a land tax certificate showing a charge on any of the land, by completion the vendor must do all things and pay all money required so that the charge is no longer effective against the land.
- Purchaser**
- 16.5 On completion the purchaser must pay to the vendor –
- 16.5.1 the price less any –
- deposit paid;
 - *FRCGW remittance payable*;
 - *GSTRW payment*; and
 - amount payable by the vendor to the purchaser under this contract; and
- 16.5.2 any other amount payable by the purchaser under this contract.
- 16.6 If any of the deposit is not covered by a *deposit-bond*, at least 1 *business day* before the date for completion the purchaser must give the vendor an order signed by the purchaser authorising the *depositholder* to account to the vendor for the deposit, to be held by the vendor in escrow until completion.
- 16.7 On completion the deposit belongs to the vendor.

17 Possession

- 17.1 *Normally*, the vendor must give the purchaser vacant possession of the *property* on completion.
- 17.2 The vendor does not have to give vacant possession if –
- 17.2.1 this contract says that the sale is subject to existing tenancies; and
- 17.2.2 the contract discloses the provisions of the tenancy (for example, by attaching a copy of the lease and any relevant memorandum or variation).
- 17.3 *Normally*, the purchaser can claim compensation (before or after completion) or *rescind* if any of the land is affected by a protected tenancy (a tenancy affected by Schedule 2, Part 7 of the Residential Tenancies Act 2010).

18 Possession before completion

- 18.1 This clause applies only if the vendor gives the purchaser possession of the *property* before completion.
- 18.2 The purchaser must not before completion –
- 18.2.1 let or part with possession of any of the *property*;
 - 18.2.2 make any change or structural alteration or addition to the *property*; or
 - 18.2.3 contravene any agreement between the *parties* or any direction, document, *legislation*, notice or order affecting the *property*.
- 18.3 The purchaser must until completion –
- 18.3.1 keep the *property* in good condition and repair having regard to its condition at the giving of possession; and
 - 18.3.2 allow the vendor or the vendor's authorised representative to enter and inspect it at all reasonable times.
- 18.4 The risk as to damage to the *property* passes to the purchaser immediately after the purchaser enters into possession.
- 18.5 If the purchaser does not comply with this clause, then without affecting any other right of the vendor –
- 18.5.1 the vendor can before completion, without notice, remedy the non-compliance; and
 - 18.5.2 if the vendor pays the expense of doing this, the purchaser must pay it to the vendor with interest at the rate prescribed under s101 Civil Procedure Act 2005.
- 18.6 If this contract is *rescinded* or *terminated* the purchaser must immediately vacate the *property*.
- 18.7 If the *parties* or their *solicitors* on their behalf do not agree in writing to a fee or rent, none is payable.

19 Rescission of contract

- 19.1 If this contract expressly gives a *party* a right to *rescind*, the *party* can exercise the right –
- 19.1.1 only by *servicing* a notice before completion; and
 - 19.1.2 in spite of any making of a claim or *requisition*, any attempt to satisfy a claim or *requisition*, any arbitration, litigation, mediation or negotiation or any giving or taking of possession.
- 19.2 *Normally*, if a *party* exercises a right to *rescind* expressly given by this contract or any *legislation* –
- 19.2.1 the deposit and any other money paid by the purchaser under this contract must be refunded;
 - 19.2.2 a *party* can claim for a reasonable adjustment if the purchaser has been in possession;
 - 19.2.3 a *party* can claim for damages, costs or expenses arising out of a breach of this contract; and
 - 19.2.4 a *party* will not otherwise be liable to pay the other *party* any damages, costs or expenses.

20 Miscellaneous

- 20.1 The *parties* acknowledge that anything stated in this contract to be attached was attached to this contract by the vendor before the purchaser signed it and is part of this contract.
- 20.2 Anything attached to this contract is part of this contract.
- 20.3 An area, bearing or dimension in this contract is only approximate.
- 20.4 If a *party* consists of 2 or more persons, this contract benefits and binds them separately and together.
- 20.5 A *party's solicitor* can receive any amount payable to the *party* under this contract or direct in writing that it is to be paid to another person.
- 20.6 A document under or relating to this contract is –
- 20.6.1 signed by a *party* if it is signed by the *party* or the *party's solicitor* (apart from a direction under clause 4.8 or clause 30.4);
 - 20.6.2 *served* if it is *served* by the *party* or the *party's solicitor*;
 - 20.6.3 *served* if it is *served* on the *party's solicitor*, even if the *party* has died or any of them has died;
 - 20.6.4 *served* if it is *served* in any manner provided in s170 of the Conveyancing Act 1919;
 - 20.6.5 *served* if it is sent by email or fax to the *party's solicitor*, unless in either case it is not received;
 - 20.6.6 *served* on a person if it (or a copy of it) comes into the possession of the person;
 - 20.6.7 *served* at the earliest time it is *served*, if it is *served* more than once; and
 - 20.6.8 *served* if it is provided to or by the *party's solicitor* or an *authorised Subscriber* by means of an *Electronic Workspace* created under clause 4. However, this does not apply to a notice making an obligation essential, or a notice of *rescission* or *termination*.
- 20.7 An obligation to pay an expense of another *party* of doing something is an obligation to pay –
- 20.7.1 if the *party* does the thing personally - the reasonable cost of getting someone else to do it; or
 - 20.7.2 if the *party* pays someone else to do the thing - the amount paid, to the extent it is reasonable.
- 20.8 Rights under clauses 4, 11, 13, 14, 17, 24, 30 and 31 continue after completion, whether or not other rights continue.
- 20.9 The vendor does not promise, represent or state that the purchaser has any cooling off rights.
- 20.10 The vendor does not promise, represent or state that any attached survey report is accurate or current.
- 20.11 A reference to any *legislation* (including any percentage or rate specified in *legislation*) is also a reference to any corresponding later *legislation*.
- 20.12 Each *party* must do whatever is necessary after completion to carry out the *party's* obligations under this contract.
- 20.13 Neither taking possession nor *servicing* a transfer of itself implies acceptance of the *property* or the title.

- 20.14 The details and information provided in this contract (for example, on pages 1 - 4) are, to the extent of each *party's* knowledge, true, and are part of this contract.
- 20.15 Where this contract provides for choices, a choice in BLOCK CAPITALS applies unless a different choice is marked.
- 20.16 Each *party* consents to –
- 20.16.1 any *party* signing this contract electronically; and
- 20.16.2 the making of this contract by the exchange of counterparts delivered by email, or by such other electronic means as may be agreed in writing by the *parties*.
- 20.17 Each *party* agrees that electronic signing by a *party* identifies that *party* and indicates that *party's* intention to be bound by this contract.

21 Time limits in these provisions

- 21.1 If the time for something to be done or to happen is not stated in these provisions, it is a reasonable time.
- 21.2 If there are conflicting times for something to be done or to happen, the latest of those times applies.
- 21.3 The time for one thing to be done or to happen does not extend the time for another thing to be done or to happen.
- 21.4 If the time for something to be done or to happen is the 29th, 30th or 31st day of a month, and the day does not exist, the time is instead the last day of the month.
- 21.5 If the time for something to be done or to happen is a day that is not a *business day*, the time is extended to the next *business day*, except in the case of clauses 2 and 3.2.
- 21.6 *Normally*, the time by which something must be done is fixed but not essential.

22 Foreign Acquisitions and Takeovers Act 1975

- 22.1 The purchaser promises that the Commonwealth Treasurer cannot prohibit and has not prohibited the transfer under the Foreign Acquisitions and Takeovers Act 1975.
- 22.2 This promise is essential and a breach of it entitles the vendor to *terminate*.

23 Strata or community title

• Definitions and modifications

- 23.1 This clause applies only if the land (or part of it) is a lot in a strata, neighbourhood, precinct or community scheme (or on completion is to be a lot in a scheme of that kind).
- 23.2 In this contract –
- 23.2.1 'change', in relation to a scheme, means –
- a registered or registrable change from by-laws set out in this contract;
 - a change from a development or management contract or statement set out in this contract; or
 - a change in the boundaries of common property;
- 23.2.2 'common property' includes association property for the scheme or any higher scheme;
- 23.2.3 'contribution' includes an amount payable under a by-law;
- 23.2.4 'information certificate' includes a certificate under s184 Strata Schemes Management Act 2015 and s171 Community Land Management Act 2021;
- 23.2.5 'interest notice' includes a strata interest notice under s22 Strata Schemes Management Act 2015 and an association interest notice under s20 Community Land Management Act 2021;
- 23.2.6 'normal expenses', in relation to an owners corporation for a scheme, means normal operating expenses usually payable from the administrative fund of an owners corporation for a scheme of the same kind;
- 23.2.7 'owners corporation' means the owners corporation or the association for the scheme or any higher scheme;
- 23.2.8 'the *property*' includes any interest in common property for the scheme associated with the lot; and
- 23.2.9 'special expenses', in relation to an owners corporation, means its actual, contingent or expected expenses, except to the extent they are –
- normal expenses;
 - due to fair wear and tear;
 - disclosed in this contract; or
 - covered by moneys held in the capital works fund.
- 23.3 Clauses 11, 14.8 and 18.4 do not apply to an obligation of the owners corporation, or to property insurable by it.
- 23.4 Clauses 14.4.2 and 14.6 apply but on a unit entitlement basis instead of an area basis.
- **Adjustments and liability for expenses**
- 23.5 The *parties* must adjust under clause 14.1 –
- 23.5.1 a regular periodic contribution;
- 23.5.2 a contribution which is not a regular periodic contribution but is disclosed in this contract; and
- 23.5.3 on a unit entitlement basis, any amount paid by the vendor for a normal expense of the owners corporation to the extent the owners corporation has not paid the amount to the vendor.

- 23.6 If a contribution is not a regular periodic contribution and is not disclosed in this contract –
- 23.6.1 the vendor is liable for it if it was determined on or before the contract date, even if it is payable by instalments; and
- 23.6.2 the purchaser is liable for all contributions determined after the contract date.
- 23.7 The vendor must pay or allow to the purchaser on completion the amount of any unpaid contributions for which the vendor is liable under clause 23.6.1.
- 23.8 *Normally*, the purchaser cannot make a claim or *requisition* or *rescind* or *terminate* in respect of –
- 23.8.1 an existing or future actual, contingent or expected expense of the owners corporation;
- 23.8.2 a proportional unit entitlement of the lot or a relevant lot or former lot, apart from a claim under clause 6; or
- 23.8.3 a past or future change in the scheme or a higher scheme.
- 23.9 However, the purchaser can *rescind* if –
- 23.9.1 the special expenses of the owners corporation at the later of the contract date and the creation of the owners corporation when calculated on a unit entitlement basis (and, if more than one lot or a higher scheme is involved, added together), less any contribution paid by the vendor, are more than 1% of the price;
- 23.9.2 in the case of the lot or a relevant lot or former lot in a higher scheme, a proportional unit entitlement for the lot is disclosed in this contract but the lot has a different proportional unit entitlement at the contract date or at any time before completion;
- 23.9.3 a change before the contract date or before completion in the scheme or a higher scheme materially prejudices the purchaser and is not disclosed in this contract; or
- 23.9.4 a resolution is passed by the owners corporation before the contract date or before completion to give to the owners in the scheme for their consideration a strata renewal plan that has not lapsed at the contract date and there is not attached to this contract a strata renewal proposal or the strata renewal plan.
- **Notices, certificates and inspections**
- 23.10 Before completion, the purchaser must *serve* a copy of an interest notice addressed to the owners corporation and signed by the purchaser.
- 23.11 After completion, the purchaser must insert the date of completion in the interest notice and send it to the owners corporation.
- 23.12 The vendor can complete and send the interest notice as agent for the purchaser.
- 23.13 The vendor must *serve* at least 7 days before the date for completion, an information certificate for the lot, the scheme or any higher scheme which relates to a period in which the date for completion falls.
- 23.14 The purchaser does not have to complete earlier than 7 days after *service* of the information certificate and clause 21.3 does not apply to this provision. On completion the purchaser must pay the vendor the prescribed fee for the information certificate.
- 23.15 The vendor authorises the purchaser to apply for the purchaser's own information certificate.
- 23.16 The vendor authorises the purchaser to apply for and make an inspection of any record or other document in the custody or control of the owners corporation or relating to the scheme or any higher scheme.
- **Meetings of the owners corporation**
- 23.17 If a general meeting of the owners corporation is convened before completion –
- 23.17.1 if the vendor receives notice of it, the vendor must immediately notify the purchaser of it; and
- 23.17.2 after the expiry of any cooling off period, the purchaser can require the vendor to appoint the purchaser (or the purchaser's nominee) to exercise any voting rights of the vendor in respect of the lot at the meeting.
- 24 Tenancies**
- 24.1 If a tenant has not made a payment for a period preceding or current at the *adjustment date* –
- 24.1.1 for the purposes of clause 14.2, the amount is to be treated as if it were paid; and
- 24.1.2 the purchaser assigns the debt to the vendor on completion and will if required give a further assignment at the vendor's expense.
- 24.2 If a tenant has paid in advance of the *adjustment date* any periodic payment in addition to rent, it must be adjusted as if it were rent for the period to which it relates.
- 24.3 If the *property* is to be subject to a tenancy on completion or is subject to a tenancy on completion –
- 24.3.1 the vendor authorises the purchaser to have any accounting records relating to the tenancy inspected and audited and to have any other document relating to the tenancy inspected;
- 24.3.2 the vendor must *serve* any information about the tenancy reasonably requested by the purchaser before or after completion; and
- 24.3.3 *normally*, the purchaser can claim compensation (before or after completion) if –
- a disclosure statement required by the Retail Leases Act 1994 was not given when required;
 - such a statement contained information that was materially false or misleading;
 - a provision of the lease is not enforceable because of a non-disclosure in such a statement; or
 - the lease was entered into in contravention of the Retail Leases Act 1994.

- 24.4 If the *property* is subject to a tenancy on completion –
- 24.4.1 the vendor must allow or transfer –
- any remaining bond money or any other security against the tenant's default (to the extent the security is transferable);
 - any money in a fund established under the lease for a purpose and compensation for any money in the fund or interest earned by the fund that has been applied for any other purpose; and
 - any money paid by the tenant for a purpose that has not been applied for that purpose and compensation for any of the money that has been applied for any other purpose;
- 24.4.2 if the security is not transferable, each *party* must do everything reasonable to cause a replacement security to issue for the benefit of the purchaser and the vendor must hold the original security on trust for the benefit of the purchaser until the replacement security issues;
- 24.4.3 the vendor must give to the purchaser –
- at least 2 *business days* before the date for completion, a proper notice of the transfer (an attornment notice) addressed to the tenant, to be held by the purchaser in escrow until completion;
 - any certificate given under the Retail Leases Act 1994 in relation to the tenancy;
 - a copy of any disclosure statement given under the Retail Leases Act 1994;
 - a copy of any document served on the tenant under the lease and written details of its service, if the document concerns the rights of the landlord or the tenant after completion; and
 - any document served by the tenant under the lease and written details of its service, if the document concerns the rights of the landlord or the tenant after completion;
- 24.4.4 the vendor must comply with any obligation to the tenant under the lease, to the extent it is to be complied with by completion; and
- 24.4.5 the purchaser must comply with any obligation to the tenant under the lease, to the extent that the obligation is disclosed in this contract and is to be complied with after completion.
- 25 Qualified title, limited title and old system title**
- 25.1 This clause applies only if the land (or part of it) –
- 25.1.1 is under qualified, limited or old system title; or
- 25.1.2 on completion is to be under one of those titles.
- 25.2 The vendor must *serve* a proper abstract of title *within 7 days* after the contract date.
- 25.3 If an abstract of title or part of an abstract of title is attached to this contract or has been lent by the vendor to the purchaser before the contract date, the abstract or part is *served* on the contract date.
- 25.4 An abstract of title can be or include a list of documents, events and facts arranged (apart from a will or codicil) in date order, if the list in respect of each document –
- 25.4.1 shows its date, general nature, names of parties and any registration number; and
- 25.4.2 has attached a legible photocopy of it or of an official or registration copy of it.
- 25.5 An abstract of title –
- 25.5.1 must start with a good root of title (if the good root of title must be at least 30 years old, this means 30 years old at the contract date);
- 25.5.2 in the case of a leasehold interest, must include an abstract of the lease and any higher lease;
- 25.5.3 *normally*, need not include a Crown grant; and
- 25.5.4 need not include anything evidenced by the Register kept under the Real Property Act 1900.
- 25.6 In the case of land under old system title –
- 25.6.1 in this contract 'transfer' means conveyance;
- 25.6.2 the purchaser does not have to *serve* the transfer until after the vendor has *served* a proper abstract of title; and
- 25.6.3 each vendor must give proper covenants for title as regards that vendor's interest.
- 25.7 In the case of land under limited title but not under qualified title –
- 25.7.1 *normally*, the abstract of title need not include any document which does not show the location, area or dimensions of the land (for example, by including a metes and bounds description or a plan of the land);
- 25.7.2 clause 25.7.1 does not apply to a document which is the good root of title; and
- 25.7.3 the vendor does not have to provide an abstract if this contract contains a delimitation plan (whether in registrable form or not).
- 25.8 On completion the vendor must give the purchaser any *document of title* that relates only to the *property*.
- 25.9 If on completion the vendor has possession or control of a *document of title* that relates also to other property, the vendor must produce it as and where necessary.
- 25.10 The vendor must give a proper covenant to produce where relevant.
- 25.11 The vendor does not have to produce or covenant to produce a document that is not in the possession of the vendor or a mortgagee.
- 25.12 If the vendor is unable to produce an original document in the chain of title, the purchaser will accept a photocopy from the *Land Registry* of the registration copy of that document.

26 Crown purchase money

- 26.1 This clause applies only if purchase money is payable to the Crown, whether or not due for payment.
 26.2 The vendor is liable for the money, except to the extent this contract says the purchaser is liable for it.
 26.3 To the extent the vendor is liable for it, the vendor is liable for any interest until completion.
 26.4 To the extent the purchaser is liable for it, the *parties* must adjust any interest under clause 14.

27 Consent to transfer

- 27.1 This clause applies only if the land (or part of it) cannot be transferred without consent under *legislation* or a *planning agreement*.
 27.2 The purchaser must properly complete and then *serve* the purchaser's part of an application for consent to transfer of the land (or part of it) *within 7 days* after the contract date.
 27.3 The vendor must apply for consent *within 7 days* after *service* of the purchaser's part.
 27.4 If consent is refused, either *party* can *rescind*.
 27.5 If consent is given subject to one or more conditions that will substantially disadvantage a *party*, then that *party* can *rescind within 7 days* after receipt by or *service* upon the *party* of written notice of the conditions.
 27.6 If consent is not given or refused –
 27.6.1 *within 42 days* after the purchaser *serves* the purchaser's part of the application, the purchaser can *rescind*; or
 27.6.2 *within 30 days* after the application is made, either *party* can *rescind*.
 27.7 Each period in clause 27.6 becomes 90 days if the land (or part of it) is –
 27.7.1 under a *planning agreement*; or
 27.7.2 in the Western Division.
 27.8 If the land (or part of it) is described as a lot in an unregistered plan, each time in clause 27.6 becomes the later of the time and 35 days after creation of a separate folio for the lot.
 27.9 The date for completion becomes the later of the date for completion and 14 days after *service* of the notice granting consent to transfer.

28 Unregistered plan

- 28.1 This clause applies only if some of the land is described as a lot in an unregistered plan.
 28.2 The vendor must do everything reasonable to have the plan registered *within 6 months* after the contract date, with or without any minor alteration to the plan or any document to be lodged with the plan validly required or made under *legislation*.
 28.3 If the plan is not registered *within* that time and in that manner –
 28.3.1 the purchaser can *rescind*; and
 28.3.2 the vendor can *rescind*, but only if the vendor has complied with clause 28.2 and with any *legislation* governing the rescission.
 28.4 Either *party* can *serve* notice of the registration of the plan and every relevant lot and plan number.
 28.5 The date for completion becomes the later of the date for completion and 21 days after *service* of the notice.
 28.6 Clauses 28.2 and 28.3 apply to another plan that is to be registered before the plan is registered.

29 Conditional contract

- 29.1 This clause applies only if a provision says this contract or completion is conditional on an event.
 29.2 If the time for the event to happen is not stated, the time is 42 days after the contract date.
 29.3 If this contract says the provision is for the benefit of a *party*, then it benefits only that *party*.
 29.4 If anything is necessary to make the event happen, each *party* must do whatever is reasonably necessary to cause the event to happen.
 29.5 A *party* can *rescind* under this clause only if the *party* has substantially complied with clause 29.4.
 29.6 If the event involves an approval and the approval is given subject to a condition that will substantially disadvantage a *party* who has the benefit of the provision, the *party* can *rescind within 7 days* after either *party* *serves* notice of the condition.
 29.7 If the *parties* can lawfully complete without the event happening –
 29.7.1 if the event does not happen *within* the time for it to happen, a *party* who has the benefit of the provision can *rescind within 7 days* after the end of that time;
 29.7.2 if the event involves an approval and an application for the approval is refused, a *party* who has the benefit of the provision can *rescind within 7 days* after either *party* *serves* notice of the refusal; and
 29.7.3 the date for completion becomes the later of the date for completion and 21 days after the earliest of –
 • either *party* *serving* notice of the event happening;
 • every *party* who has the benefit of the provision *serving* notice waiving the provision; or
 • the end of the time for the event to happen.

- 29.8 If the *parties* cannot lawfully complete without the event happening –
- 29.8.1 if the event does not happen *within* the time for it to happen, either *party* can *rescind*;
- 29.8.2 if the event involves an approval and an application for the approval is refused, either *party* can *rescind*;
- 29.8.3 the date for completion becomes the later of the date for completion and 21 days after either *party* serves notice of the event happening.
- 29.9 A *party* cannot *rescind* under clauses 29.7 or 29.8 after the event happens.
- 30 Manual transaction**
- 30.1 This clause applies if this transaction is to be conducted as a *manual transaction*.
- **Transfer**
- 30.2 *Normally*, the purchaser must *serve* the transfer at least 7 days before the date for completion.
- 30.3 If any information needed for the transfer is not disclosed in this contract, the vendor must *serve* it.
- 30.4 If the purchaser *serves* a transfer and the transferee is not the purchaser, the purchaser must give the vendor a direction signed by the purchaser personally for that transfer.
- 30.5 The vendor can require the purchaser to include a covenant or easement in the transfer only if this contract contains the wording of the proposed covenant or easement, and a description of the land burdened and benefited.
- **Place for completion**
- 30.6 *Normally*, the *parties* must complete at the completion address, which is –
- 30.6.1 if a special completion address is stated in this contract - that address; or
- 30.6.2 if none is stated, but a first mortgagee is disclosed in this contract and the mortgagee would usually discharge the mortgage at a particular place - that place; or
- 30.6.3 in any other case - the vendor's *solicitor's* address stated in this contract.
- 30.7 The vendor by reasonable notice can require completion at another place, if it is in NSW, but the vendor must pay the purchaser's additional expenses, including any agency or mortgagee fee.
- 30.8 If the purchaser requests completion at a place that is not the completion address, and the vendor agrees, the purchaser must pay the vendor's additional expenses, including any agency or mortgagee fee.
- **Payments on completion**
- 30.9 On completion the purchaser must pay to the vendor the amounts referred to in clauses 16.5.1 and 16.5.2, by cash (up to \$2,000) or *settlement cheque*.
- 30.10 *Normally*, the vendor can direct the purchaser to produce a *settlement cheque* on completion to pay an amount adjustable under this contract and if so –
- 30.10.1 the amount is to be treated as if it were paid; and
- 30.10.2 the *cheque* must be forwarded to the payee immediately after completion (by the purchaser if the *cheque* relates only to the *property* or by the vendor in any other case).
- 30.11 If the vendor requires more than 5 *settlement cheques*, the vendor must pay \$10 for each extra *cheque*.
- 30.12 If the purchaser must make a *GSTRW payment* the purchaser must –
- 30.12.1 produce on completion a *settlement cheque* for the *GSTRW payment* payable to the Deputy Commissioner of Taxation;
- 30.12.2 forward the *settlement cheque* to the payee immediately after completion; and
- 30.12.3 *serve* evidence of receipt of payment of the *GSTRW payment* and a copy of the settlement date confirmation form submitted to the Australian Taxation Office.
- 30.13 If the purchaser must pay an *FRCGW remittance*, the purchaser must –
- 30.13.1 produce on completion a *settlement cheque* for the *FRCGW remittance* payable to the Deputy Commissioner of Taxation;
- 30.13.2 forward the *settlement cheque* to the payee immediately after completion; and
- 30.13.3 *serve* evidence of receipt of payment of the *FRCGW remittance*.
- 31 Foreign Resident Capital Gains Withholding**
- 31.1 This clause applies only if –
- 31.1.1 the sale is not an excluded transaction within the meaning of s14-215 of Schedule 1 to the *TA Act*; and
- 31.1.2 a *clearance certificate* in respect of every vendor is not attached to this contract.
- 31.2 If the vendor *serves* any *clearance certificate* or *variation*, the purchaser does not have to complete earlier than 5 *business days* after that *service* and clause 21.3 does not apply to this provision.
- 31.3 The purchaser must at least 2 *business days* before the date for completion, *serve* evidence of submission of a purchaser payment notification to the Australian Taxation Office by the purchaser or, if a direction under either clause 4.8 or clause 30.4 has been given, by the transferee named in the transfer the subject of that direction.
- 31.4 The vendor cannot refuse to complete if the purchaser complies with clause 31.3 and, as applicable, clauses 4.10 or 30.13.
- 31.5 If the vendor *serves* in respect of every vendor either a *clearance certificate* or a *variation* to 0.00 percent, clauses 31.3 and 31.4 do not apply.

32 Residential off the plan contract

- 32.1 This clause applies if this contract is an off the plan contract within the meaning of Division 10 of Part 4 of the Conveyancing Act 1919 (the Division).
- 32.2 No provision of this contract has the effect of excluding, modifying or restricting the operation of the Division.
- 32.3 If the purchaser makes a claim for compensation under the terms prescribed by sections 4 to 6 of Schedule 3 to the Conveyancing (Sale of Land) Regulation 2022 –
 - 32.3.1 the purchaser cannot make a claim under this contract about the same subject matter, including a claim under clauses 6 or 7; and
 - 32.3.2 the claim for compensation is not a claim under this contract.

372 Ocean View Road, Ettalong Beach NSW 2257

AUCTION

- (1) The following conditions are prescribed as applicable to and in respect of the sale by auction of land or livestock:
 - (a) The principal's reserve price must be given in writing to the auctioneer before the auction commences.
 - (b) A bid for the seller cannot be made unless the auctioneer has, before the commencement of the auction, announced clearly and precisely the number of bids that may be made by or on behalf of the seller.
 - (c) The highest bidder is the purchaser, subject to any reserve price.
 - (d) In the event of a disputed bid, the auctioneer is the sole arbitrator and the auctioneer's decision is final.
 - (e) The auctioneer may refuse to accept any bid that, in the auctioneer's opinion, is not in the best interests of the seller.
 - (f) A bidder is taken to be a principal unless, before bidding, the bidder has given to the auctioneer a copy of a written authority to bid for or on behalf of another person.
 - (g) A bid cannot be made or accepted after the fall of the hammer.
 - (h) As soon as practicable after the fall of the hammer the purchaser is to sign the agreement (if any) for sale.
- (2) The following conditions, in addition to those prescribed by subclause (1), are prescribed as applicable to and in respect of the sale by auction of residential property or rural land:
 - (a) All bidders must be registered in the Bidders Record and display an identifying number when making a bid.
 - (b) One bid only may be made by or on behalf of the seller. This includes a bid made by the auctioneer on behalf of the seller.
 - (c) When making a bid on behalf of the seller or accepting a bid made by or on behalf of the seller, the auctioneer must clearly state that the bid was made by or on behalf of the seller or auctioneer.
- (3) The following condition, in addition to those prescribed by subclause (1), is prescribed as applicable to and in respect of the sale by auction of livestock. The purchaser of livestock must pay the stock and station agent who conducted the auction or the vendor the full amount of the purchase price:
 - (a) If that amount can reasonably be determined immediately after the fall of the hammer-before the close of the next business day following the auction, or
 - (b) if that amount cannot reasonably be determined immediately after the fall of the hammer-before the close of the next business day following determination of that amount, unless some other time for payment is specified in a written agreement between the purchaser and the agent or the purchaser and the vendor made before the fall of the hammer.

ANNEXURE TO AGREEMENT FOR SALE OF LAND

Between: MARCELLO TOTARO & TOMMASO TOTARO (Vendor)

And: (Purchaser)

1. NO WARRANTY ON FURNISHINGS AND CHATTELS

The Purchaser hereby acknowledges that any furnishings and chattels included in this sale are used goods and are sold without any warranty as to condition and fitness and the Vendor shall not be liable for any fair wear and tear of any such furnishings and chattels as from the date of this Agreement.

2. PROPERTY AND IMPROVEMENTS

The Purchaser hereby acknowledges that the Purchaser has purchased the property and the improvements thereon in their present physical condition and state of repair and the Purchaser hereby agrees not to make any objections, requisitions or claim for compensation with respect to the physical condition and state of repair of the property and/or such improvements.

3. DEATH/MENTAL ILLNESS

Without in any manner negating, limiting or restricting any rights or remedies which would have been available to the parties at law or in equity had this clause not been included herein it is agreed that if a party shall die or become mentally ill then the other party may by notice in writing to the other party's solicitor named herein rescind this contract whereupon the provisions of Clause 19 hereof shall apply.

4. NOTICE TO COMPLETE

In the event that this Contract is not completed by the time stipulated as the Completion Date on the front page of the Contract, either party shall be entitled to issue a Notice to Complete fixing a time for completion which time shall be of the essence of this Contract and such Notice shall be deemed to be sufficient as to time if a period of not less than fourteen (14) days from the date of service of such Notice is allowed for completion.

5. INTEREST

In the event that completion does not take place by the Completion Date stipulated on the front page of the Contract due solely to the Purchaser's fault, the Purchaser shall pay interest on the balance of purchase monies to the Vendor on actual completion at the rate of 8% per annum from and including the said Completion Date up to and including the date of actual completion.

6. GUARANTEE AND INDEMNITY

- (a) If the Purchaser is a corporation it is an essential term of this Contract that the directors of the Purchaser ("the Guarantors") by executing this Contract as officers of the Purchaser jointly and severally guarantee to the Vendor the due and punctual performance and observance by the Purchaser of its obligations under this Contract and indemnify the Vendor against all losses, damages, liabilities, costs and expenses accruing to the Vendor resulting or arising from

any failure by the Purchaser to perform or observe any of the obligation on its part to be performed or observed.

- (b) This Guarantee and Indemnity is a contributing obligation and cannot be abrogated, prejudiced or discharged by any waiver by the Vendor or by any other matter. Any rescission or termination will not waive the obligations arising under this clause.
- (c) This Guarantee and Indemnity is a principal obligation between the Guarantors and the Vendor.

7. INDEMNITY BY PURCHASER RE COMMISSION BY OTHER AGENTS

The Purchaser warrants to the Vendor that it was not introduced to the property by any agent other than the agent referred to herein. The Purchaser agrees to indemnify and keep indemnified the Vendor against any claim for commission by any agent other than the agent referred to herein arising out of breach of this warranty. This condition shall not merge on completion.

8. DEPOSIT

Notwithstanding the provisions of any other clause in this contract for sale the Purchaser agrees:

In the event that the Vendor at the request of the Purchaser agrees to accept a lesser deposit than 10% of the purchase price on exchange of this Contract, the Vendor will enter this contract in consideration for the Purchaser agreeing that the deposit shall be paid by way of instalments in the following manner:

- (a) A part deposit of 5% of the purchase price on exchange of Contracts; and,
- (b) As an assurance of the bargain the balance of the 10% deposit on the completion date of the Contract, or if not completed on the date of breach by the Purchaser of an essential term of the Contract.
- (c) The Purchaser acknowledges that payment of the balance of the 10% deposit as agreed to in this clause is not a penalty provision.

RESIDENTIAL PROPERTY REQUISITIONS ON TITLE

Vendor: **Marcello Totaro & Tommaso Totaro**

Purchaser:

Property: **372 Ocean View Road, Ettalong Beach**

Dated:

Possession and tenancies

1. Vacant possession of the Property must be given on completion unless the Contract provides otherwise.
2. Is anyone in adverse possession of the Property or any part of it?
3.
 - (a) What are the nature and provisions of any tenancy or occupancy?
 - (b) If they are in writing, all relevant documentation should be produced, found in order and handed over on completion with notices of attornment.
 - (c) Please specify any existing breaches.
 - (d) All rent should be paid up to or beyond the date of completion.
 - (e) Please provide details of any bond together with the Rental Bond Board's reference number.
 - (f) If any bond money is held by the Rental Bond Board, the appropriate transfer documentation duly signed should be handed over on completion.
4. Is the Property affected by a protected tenancy (a tenancy affected by Schedule 2, Part 7 of the *Residential Tenancies Act 2010* (NSW))? If so, please provide details.
5. If the tenancy is subject to the *Residential Tenancies Act 2010* (NSW):
 - (a) has either the vendor or any predecessor or the tenant applied to the NSW Civil and Administrative Tribunal for an order?
 - (b) have any orders been made by the NSW Civil and Administrative Tribunal? If so, please provide details.

Title

6. Subject to the Contract, on completion the vendor should be registered as proprietor in fee simple of the Property free from all encumbrances and notations.
7. On or before completion, any mortgage, caveat, writ or priority notice must be discharged, withdrawn, cancelled or removed as the case may be or, in the case of a mortgage, caveat or priority notice, an executed discharge or withdrawal or removal handed over on completion.
8. Are there any proceedings pending or concluded that could result in the recording of any writ on the title to the Property or in the General Register of Deeds? If so, full details should be provided at least 14 days prior to completion.
9. When and where may the title documents be inspected?
10. Are any chattels or fixtures subject to any hiring or leasing agreement or charge or to any security interest under the *Personal Property Securities Act 2009* (Cth)? If so, details must be given and all indebtedness cleared and title transferred unencumbered to the vendor prior to completion.

Adjustments

11. All outgoings referred to in clause 14.1 and 23.5 to 23.7 (inclusive) of the Contract must be paid up to and including the date of completion.
12. Is the vendor liable to pay land tax or is the Property otherwise charged or liable to be charged with land tax? If so:
 - (a) to what year has a return been made?
 - (b) what is the taxable value of the Property for land tax purposes for the current year?
13. If any land tax certificate shows a charge for land tax on the land, the vendor must produce evidence at completion that the charge is no longer effective against the land.

Survey and building

14. Subject to the Contract, the survey should be satisfactory and show that the whole of the Property is available and that there are no encroachments by or upon the Property and that all improvements comply with local government/planning legislation.

15. Is the vendor in possession of a survey report? If so, please produce a copy for inspection prior to completion. The original should be handed over on completion.
- 16.
- (a) Have the provisions of the *Local Government Act 1993* (NSW), the *Environmental Planning and Assessment Act 1979* (NSW) and their regulations been complied with?
 - (b) Is there any matter that could justify the making of an upgrading or demolition order in respect of any building or structure?
 - (c) Has the vendor a Building Information Certificate or a Building Certificate which relates to all current buildings or structures? If so, it should be handed over on completion. Please provide a copy in advance.
 - (d) Has the vendor a Final Occupation Certificate (as referred to in the former Section 109C of the *Environmental Planning and Assessment Act 1979* (NSW)) or an Occupation Certificate as referred to in Section 6.4 of the *Environmental Planning and Assessment Act 1979* (NSW) for all current buildings or structures? If so, it should be handed over on completion. Please provide a copy in advance.
 - (e) In respect of any residential building work carried out in the last 7 years:
 - (i) please identify the building work carried out;
 - (ii) when was the building work completed?
 - (iii) please state the builder's name and licence number;
 - (iv) please provide details of insurance or any alternative indemnity product under the *Home Building Act 1989* (NSW).
 - (f) Have any actions been taken, including the issuing of any notices or orders, relating to any building or building works under the *Residential Apartment Buildings (Compliance and Enforcement Powers) Act 2020* (NSW) or have any undertakings been given by any developer under that Act? Any outstanding obligations should be satisfied by the vendor prior to completion.
- 17.
- (a) Has the vendor (or any predecessor) entered into any agreement with or granted any indemnity to the Council or any other authority concerning any development on the Property?
 - (b) Is there any planning agreement or other arrangement referred to in Section 7.4 of the *Environmental Planning and Assessment Act 1979* (NSW), (registered or unregistered) affecting the Property? If so please provide details and indicate if there are any proposals for amendment or revocation?
18. If a swimming pool is included in the sale:
- (a) did its installation or construction commence before or after 1 August 1990?
 - (b) has the swimming pool been installed or constructed in accordance with approvals under the *Local Government Act 1919* (NSW) and *Local Government Act 1993* (NSW)?
 - (c) does it comply with the provisions of the *Swimming Pools Act 1992* (NSW) and regulations relating to access? If not, please provide details or the exemptions claimed;
 - (d) have any notices or orders issued or been threatened under the *Swimming Pools Act 1992* (NSW) or regulations?
 - (e) if a certificate of non-compliance has issued, please provide reasons for its issue if not disclosed in the contract;
 - (f) originals of certificate of compliance or non-compliance and occupation certificate should be handed over on settlement.
- 19.
- (a) To whom do the boundary fences belong?
 - (b) Are there any party walls?
 - (c) If the answer to Requisition 19(b) is yes, specify what rights exist in relation to each party wall and produce any agreement. The benefit of any such agreement should be assigned to the purchaser on completion.
 - (d) Is the vendor aware of any dispute regarding boundary or dividing fences or party walls?
 - (e) Has the vendor received any notice, claim or proceedings under the *Dividing Fences Act 1991* (NSW) or the *Encroachment of Buildings Act 1922* (NSW)?

Affectations/Benefits

- 20.
- (a) Is the vendor aware of any rights, licences, easements, covenants or restrictions as to use affecting or benefiting the Property other than those disclosed in the Contract? If a licence benefits the Property please provide a copy and indicate:
 - (i) whether there are any existing breaches by any party to it;
 - (ii) whether there are any matters in dispute; and
 - (iii) whether the licensor holds any deposit, bond or guarantee.
 - (b) In relation to such licence:
 - (i) All licence fees and other moneys payable should be paid up to and beyond the date of completion;

- (ii) The vendor must comply with all requirements to allow the benefit to pass to the purchaser.
21. Is the vendor aware of:
- (a) any road, drain, sewer or storm water channel which intersects or runs through the land?
 - (b) any dedication to or use by the public of any right of way or other easement over any part of the land?
 - (c) any latent defects in the Property?
22. Has the vendor any notice or knowledge that the Property is affected by the following:
- (a) any resumption or acquisition or proposed resumption or acquisition?
 - (b) any notice requiring work to be done or money to be spent on the Property or any footpath or road adjoining? If so, such notice must be complied with prior to completion.
 - (c) any work done or intended to be done on the Property or the adjacent street which may create a charge on the Property or the cost of which might be or become recoverable from the purchaser?
 - (d) any sum due to any local or public authority? If so, it must be paid prior to completion.
 - (e) any realignment or proposed realignment of any road adjoining the Property?
 - (f) the existence of any contamination including, but not limited to, materials or substances dangerous to health such as asbestos and fibreglass or polyethylene or other flammable or combustible material including cladding?
23. If the Property is a building or part of a building to which external combustible cladding has been applied, has the owner provided to the Planning Secretary details of the building and the external combustible cladding and is the building recorded in the Register maintained by the Secretary?
- 24.
- (a) Does the Property have the benefit of water, sewerage, drainage, electricity, gas and telephone services?
 - (b) If so, do any of the connections for such services pass through any adjoining land?
 - (c) Do any service connections for any other property pass through the Property?
25. Has any claim been made by any person to close, obstruct or limit access to or from the Property or to prevent the enjoyment of any rights appurtenant to the Property?

Capacity

26. If the Contract discloses that the vendor is a trustee, evidence should be produced to establish the trustee's power of sale.

Requisitions and transfer

27. If not attached to the Contract and the transaction is not an excluded transaction, any *clearance certificate* under Section 14-220 of Schedule 1 of the *Taxation Administration Act 1953* (Cth) should be served on the purchaser at least 7 days prior to completion.
28. The vendor should furnish completed details within the time specified in the contract, sufficient to enable the purchaser to make any *GSTRW* payment.
29. If any document required for completion is executed pursuant to a power of attorney, then at least 7 days prior to completion a copy of the registered power of attorney should be produced and found in order.
30. If the vendor holds a certificate of title, it must be delivered to the purchaser immediately after completion or as directed by the purchaser, in accordance with the Contract.
31. Searches, surveys, enquiries and inspection of title deeds must prove satisfactory.
32. The purchaser reserves the right to make further requisitions prior to completion.
33. Unless we are advised by you to the contrary prior to completion, it will be assumed that your replies to these requisitions remain unchanged as at the completion date.

Off the plan contract

34. If the Contract is an off the plan contract:
- (a) Is the vendor aware of any inaccuracy in the disclosure statement attached to the Contract? If so, please provide particulars.
 - (b) The vendor should before completion serve on the purchaser a copy of the registered plan and any document that was registered with the plan.
 - (c) Please provide details, if not already given, of the holding of the deposit or any instalment as trust or controlled monies by a real estate agent, licensed conveyancer or law practice.
 - (d) Has any developer provided to the Secretary of the Department of Customer Services an expected completion notice under the *Residential Apartment Buildings (Compliance and Enforcement Powers) Act 2020* (NSW) in relation to the Property? If so, when was it made?
 - (e) The vendor should provide an occupation certificate as referred to in Section 6.4 of the *Environmental Planning and Assessment Act 1979* (NSW) for all buildings or structures on the Property.



FOLIO: 9/24978

SEARCH DATE	TIME	EDITION NO	DATE
21/8/2025	10:19 AM	3	9/9/2018

LAND

LOT 9 IN DEPOSITED PLAN 24978
LOCAL GOVERNMENT AREA CENTRAL COAST
PARISH OF PATONGA COUNTY OF NORTHUMBERLAND
TITLE DIAGRAM DP24978

FIRST SCHEDULE

MARCELLO TOTARO
IN 1/2 SHARE
TOMMASO TOTARO
IN 1/2 SHARE
AS TENANTS IN COMMON (CN AE345840)

SECOND SCHEDULE (5 NOTIFICATIONS)

- RESERVATIONS AND CONDITIONS IN THE CROWN GRANT(S)
- G127597 RIGHT OF FOOTWAY AFFECTING PART OF THE LAND SHOWN
0.915 WIDE IN DP24978
- G127597 RIGHT OF CARRIAGEWAY APPURTENANT TO THE LAND ABOVE
DESCRIBED AFFECTING PART OF THE LAND SHOWN RIGHT OF
WAY 3.05 WIDE AND VARIABLE WIDTH IN DP24978
- K77228 RIGHT OF CARRIAGEWAY APPURTENANT TO THE LAND ABOVE
DESCRIBED AFFECTING PART OF THE LAND SHOWN RIGHT OF
WAY 3.05 WIDE IN DP24978
- AE183257 MORTGAGE TO NATIONAL AUSTRALIA BANK LIMITED

NOTATIONS

UNREGISTERED DEALINGS: NIL

*** END OF SEARCH ***

2231536...

PRINTED ON 21/8/2025

* Any entries preceded by an asterisk do not appear on the current edition of the Certificate of Title. Warning: the information appearing under notations has not been formally recorded in the Register. InfoTrack an approved NSW Information Broker hereby certifies that the information contained in this document has been provided electronically by the Registrar General in accordance with Section 96B(2) of the Real Property Act 1900.

Plan Form No. 2 (for Deposited Plan)
 Municipality of Shire of Gosford
 F824582-18-3-53
 PLAN
 of subdivision of Lots 8 & 9, Sec 2 and Lots 26 & 27, Sec 1, DP 5298
 DEF PLAN 24978
 14 September 53

PARISH OF PATONGA COUNTY OF NORTHUMBERLAND

Scale: 50 feet to an inch

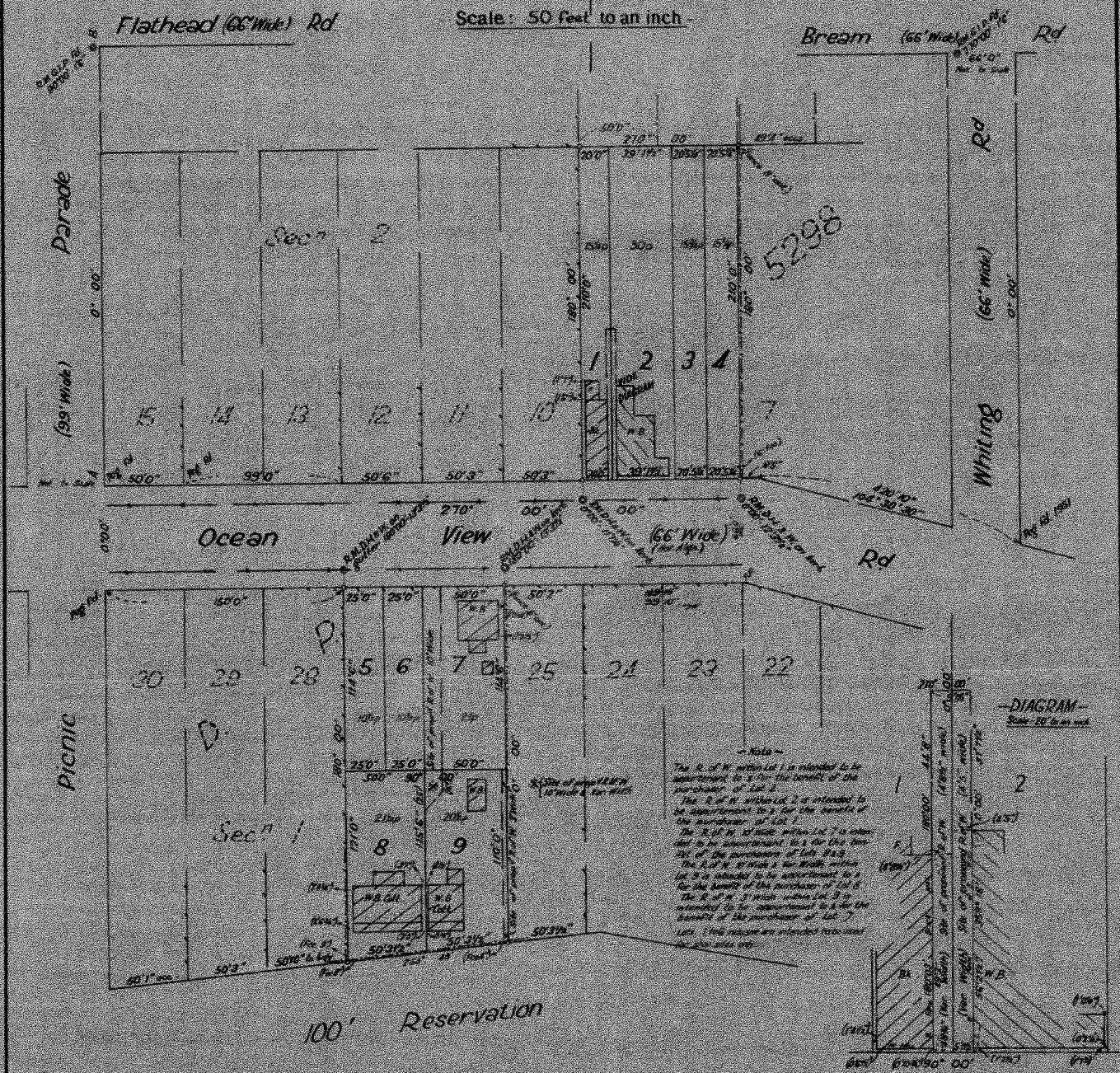

Note
 The R. of N. within lot 1 is intended to be apportioned to 1/2 the benefit of the purchaser of lot 2.
 The R. of N. within lot 2 is intended to be apportioned to 1/2 for the benefit of the purchaser of lot 1.
 The R. of N. within lot 7 is intended to be apportioned to 1/2 for the benefit of the purchaser of lot 8 & 9.
 The R. of N. within lot 8 is intended to be apportioned to 1/2 for the benefit of the purchaser of lot 9.
 The R. of N. within lot 9 is intended to be apportioned to 1/2 for the benefit of the purchaser of lot 8.
 Lots 1 & 6 are intended to be used for the purpose of a public road.

I, **Edward Sydney James Hunter** of Gosford a Surveyor registered under the Surveyors Act, 1919, do hereby certify and declare that the above plan and measurements shown on this plan are correct and that the same have been measured and reduced to the level of the mean sea level and that the boundaries are correctly represented by the lines shown on this plan and that the same are correctly represented in the plan and that the same have been made in accordance with the Surveyors Act, 1919 and the Surveyors Regulations, 1920 and that the same are correct and that the same have been made in accordance with the Surveyors Act, 1919 and the Surveyors Regulations, 1920 and that the same are correct and that the same have been made in accordance with the Surveyors Act, 1919 and the Surveyors Regulations, 1920.

Approved by Council & Covered by Council Clerk's Certificate
 No. 998 of 6/1/53
 [Signature]
 Council Clerk

Subscribed and declared before me at Gosford
 this 31st day of December A.D. 1952
 [Signature]
 Date of Survey 24.11.52

(Signature)
 Surveyor registered under the Surveyors Act, 1919
 Date of Survey 24.11.52



CONVERSION TABLE ADDED IN
 REGISTRAR GENERAL'S DEPARTMENT

DP 24978

FEET INCHES	METRES
- 2 1/4	0.057
- 3 5/8	0.092
- 4	0.102
- 4 1/2	0.114
- 5 3/4	0.146
- 6	0.152
- 6 1/2	0.165
- 7 1/4	0.184
- 8	0.203
- 9	0.229
- 10 3/4	0.273
1 0 1/4	0.311
1 0 3/4	0.324
1 2 1/2	0.368
1 4 1/2	0.419
1 4 3/4	0.425
1 6	0.457
1 7	0.483
1 7 1/4	0.489
2 4 3/4	0.730
2 6 3/4	0.781
2 7 3/4	0.806
3 -	0.914
3 1	0.940
4 5	1.346
4 8 1/4	1.429
4 8 1/2	1.435
4 8 3/4	1.441
5 1 1/2	1.562
8 5	2.565
9 1 1/2	2.781
10 -	3.048
11 1 1/4	3.385
12 3 1/2	3.747
15 3 1/2	4.051
15 -	4.572
20 -	6.096
20 5 1/4	6.229
25 -	7.620
37 7 1/2	11.468
39 1 1/2	11.925
39 3 3/4	11.982
44 8	15.614
49 2	14.986
49 4	15.037
50 -	15.240
50 1	15.265
50 2	15.291
50 3	15.316
50 3 1/2	15.329
50 6	15.392
50 10	15.494
56 2 1/2	17.132
66 -	20.117
99 -	30.175
99 10	30.429
110 -	33.528
114 6	34.900
115 6	35.204
121 -	36.881
150 -	45.720
210 -	64.008
420 10	128.270
AC RD P	SQ M
- - 10 1/2	265.6
- - 15 1/4	385.7
- - 15 3/4	398.4
- - 20 1/2	518.5
- - 21	531.1
- - 21 1/2	543.8
- - 30	758.8

'65 AUG 13 PM 2:23

RP 13

No. **K 77228**



New South Wales

MEMORANDUM OF TRANSFER
 (REAL PROPERTY ACT, 1900)



Fees:—
 Lodgment 2.100
 Endorsement 2.000
 4.100
 13.8.6

(Trusts must not be disclosed in the transfer.)

Typing or handwriting in this instrument should not extend into any margin. Handwriting should be clear and legible and in permanent black non-copying ink.

If a test estate, strike out "in fee simple" and insert the required alteration.

State in full the name of the person who furnished the consideration money.

Show in BLOCK LETTERS the full name, postal address and description of the persons taking.

If more than one person is taking, state whether they hold as joint tenants or tenants in common.

The description may refer to the defined residue of the land in a certificate of grant (eg. "and being residue after Transfer No. ...") or may refer to parcels shown in Town or Parish Maps issued by the Dept. of Lands or shown in plans filed in the Office of the Registrar-General (eg. "and being lot ... D.P. ..."). Unless authorized by Reg. 63 of the Conveyancing Act Regulations, 1961, a plan may not be annexed to or endorsed on this transfer form.

A very short note will suffice.

Execution in New South Wales may be proved in this instrument in a signed or acknowledged before the Registrar-General or Deputy Registrar-General, or a Notary Public, a J.P., or Commissioner for Affidavits, to whom the Transferor is known, otherwise the attesting witness should appear before one of the above functionaries who having questioned the witness should sign the certificate on the back of this form.

As to instruments executed elsewhere, see Section 107 of the Real Property Act, 1900, Section 166 of the Conveyancing Act, 1919, and Section 52A of the Evidence Act, 1958.

Repeat attestation if necessary.

If the Transferor or Transferee signs by a mark, the attestation must state "that the instrument was read over and explained to him and that he appeared fully to understand the same."

I, GRACE MILES SMITH Wife of Alex Miles-Smith of 364 Moore Park Road Paddington Retired Butcher (formerly Grace Miles of Paddington Widow)

being registered as the proprietor of an estate in fee simple in the land hereinafter described, have transferred to such transferee(s) the land and interest therein as are notified hereunder in consideration of

the sum of **£2,553.12.0** (the receipt whereof is hereby acknowledged) paid to me by **CECILIA SALLY JORDAN**

do hereby transfer to

CECILIA SALLY JORDAN of 44 Vaucluse Road Vaucluse Spinster
 (herein called transferee)

ALL such my Estate and Interest in ALL THE land mentioned in the schedule following:—

County	Parish	Reference to Title			Description of Land (if part only)
		Whole or Part	Vol.	Fol.	
Northumberland	Patonga	Whole	7312	131	— —
Together with a Right of Carriage Way appurtenant to Lot 8 in Deposited Plan 24978 hereby transferred over that part of lot 9 in Deposited Plan 24978 (being the land comprised in Certificate of Title Volume 588 Folio 244) shown on the said Deposited Plan 24978 as "Site of Proposed Right of Way ten feet wide and variable width".					

ENCUMBRANCES, &c., REFERRED TO

- N I I -

Signed at *Sydney* the *Tenth* day of *May*, 1965

Signed in my presence by the transferor WHO IS PERSONALLY KNOWN TO ME

William Reynolds J.P.

Grace Miles-Smith
 Transferor

Signed

Accepted, and I hereby certify this Transfer to be correct for the purposes of the Real Property Act.

Signed in my presence by the transferee

WHO IS PERSONALLY KNOWN TO ME

Richard
Stewart Transferee(s)

* If signed by virtue of any power of attorney, the original power must be registered in the Miscellaneous Register, and produced with each dealing, and the memorandum of non-revocation on back of form signed by the attorney before a witness.

† N.B.—Section 117 requires that the above Certificate be signed by each Transferee or his Solicitor or Conveyancer, and renders any person falsely or negligently certifying liable to a penalty of £50; also to damages recoverable by parties injured. Acceptance by the Solicitor or Conveyancer (who must sign his own name, and not that of his firm) is permitted only when the signature of the Transferee cannot be obtained without difficulty, and when the instrument does not impose a liability on the party taking it. When the instrument contains some special covenant by the Transferee or is subject to a mortgage, encumbrance or lease, the Transferee must accept personally.

No alterations should be made by erasure. The words rejected should be scored through with the pen, and those substituted written over them, the alteration being verified by signature or initials in the margin, or noticed in the attestation.

20933D/65

THIS SPACE TO BE LEFT FREE FROM NOTATION

NOT TO BE ALTERED BY ERASURE—See Foot Note

K 77223

PARTIAL DISCHARGE OF MORTGAGE
(N.B. Before execution check mortgage notes)

LODGED BY: PERCY L. WILLIAMSON & CO.
 Address: 375 George Street, Sydney
 Phone No.: BX4433.

I, **THE COMMERCIAL BANK OF AUSTRALIA LIMITED**, mortgagee under Mortgage No. H352406
~~release and discharge the land comprised in the within transfer from such mortgage and all claims thereunder but without prejudice to my rights and remedies as regards the balance of the land comprised in such mortgage.~~
 hereby consent to the within mentioned Grant of Right of Way.

This discharge is appropriate to a transfer of part of the land in the Mortgage. The mortgagee should execute a formal discharge where the land transferred is the whole of or the residue of the land in the Certificate of Title or Crown Grant or in the whole of the land in the mortgage.

Dated at Sydney this twenty ninth day of July, 1965.
 Signed in my presence by J. L. Frank
 Signed at Sydney on the 29th day of July 1965
 at the Commercial Bank of Australia Limited who is personally known to me.

 MANAGER AM of BANK

MEMORANDUM AS TO NON-REVOCATION OF POWER OF ATTORNEY

(To be signed at the time of executing the within instrument)

Memorandum whereby the undersigned states that he has no notice of the revocation of the Power of Attorney registered No. _____ Miscellaneous Register under the authority of which he has just executed the within transfer.

Signed at _____ the _____ day of _____, 19 ____
 Signed in the presence of _____

Strike out unnecessary words. Add any other matter necessary to show that the power is effective.

CERTIFICATE OF J.P. & Co., TAKING DECLARATION OF ATTESTING WITNESS

Appeared before me at _____, the _____ day of _____, one thousand nine hundred and _____ the attesting witness to this instrument and declared that he personally know _____ the person signing the same, and whose signature thereto he has attested; and that the name purporting to be such signature of the said _____ is _____ own handwriting, and that he was of sound mind and voluntarily signed the same.

To be signed by Registrar General, Deputy Registrar General, a Notary Public, J.P., Commissioner for Affidavits, or other functionary before whom the attesting witness appears. Not required if the instrument itself be signed or acknowledged before one of these parties.

LEAVE THESE SPACES FOR DEPARTMENTAL USE
 Index - 1157 - 1/19/65

INDEXED	MEMORANDUM OF TRANSFER <i>together with Right of Carriageway</i>
Checked by	Particulars entered in Register Book, on <u>24</u> <u>9</u> 19 <u>65</u>
Passed (in S.D.B.) by	at <u>17</u> <u>MOORE</u>
Signed by	<i>Jawataon</i> Registrar General

DOCUMENTS LODGED HEREWITH To be filled in by person lodging dealing	
1. <i>[Signature]</i>	Received Docs. Nos.
2. <i>[Signature]</i>	Receiving Clerk.
3. <i>[Signature]</i>	

PROCESS RECORD		Initials	Date
Sent to Survey Branch			
Received from Records			
Draft written			
Draft examined			
Diagram prepared			
Diagram examined			
Draft forwarded			
Supt. of Engrs. Sers			
Cancellation Clerk			
Vol.		Fol.	

FEES.
 The Fees, which are payable on lodgment, are as follows:-
 (a) \$2 10c. Od. where the memorandum of transfer is accompanied by the relevant Certificate of Title or Crown Grants, otherwise \$3. Where such instrument is to be endorsed on more than one folium of the register, an additional charge of 5c. is made for every Certificate of Title or Crown Grant after the first.
 (b) A supplementary charge of \$1 is made in each of the following:-
 (i) where a restrictive covenant is imposed; or
 (ii) a new easement is created; or
 (iii) a partial discharge of mortgage is endorsed on the transfer.

(No. 111)

STATUTORY DECLARATION

I, GRACE MILES-SMITH of Flat 29, 364 Moore Park Road,
Paddington in the State of New South Wales Married Woman

do solemnly and sincerely declare that

1. I am the same person as and identical to GRACE MILES of Paddington, Widow noted as the Registered Proprietor of the land contained in Certificate of Title Volume 7312 Folio 131.
2. On the 23rd day of December 1959 I married ALEXANDER SMITH at Sydney as per copy Marriage Certificate annexed hereto and marked with the letter "A".
Joseph
3. By Deed Poll Registered No. 61487 the name was changed to "MILES-SMITH".

B

And I make this solemn declaration conscientiously believing the same to be true and by virtue of the provisions of the Oaths Act, 1900.

Subscribed and declared at Sydney
this Twenty day of May
one thousand nine hundred and sixty five
before me

Grace Miles-Smith

Norman Reynolds
J.P.

RR FORM No. 9

39215/65



No. of Application

MARRIAGES registered in the District of Sydney, in the State of New South Wales, Registered by Jack Hayward Watson, Registrar General.

This is the annexure marked "A" referred and mentioned to in the Statutory Declaration of GRACE MILES-SMITH made before me this twelfth day of May, 1965.

1	Number in Register	22768	7695
2	When and where married.	23rd December, 1958 Wesley Chapel, Sydney	
3	Names and Surname of parties.	Alexander Joseph Smith	Grace Frances Agnes Miles
4	Occupation	Physiotherapist	Physiotherapist
5	Usual place of residence	231 Old South Head Road, Bondi	Flat 29 364 Moore Park Road, Paddington
6	Conjugal condition	Divorced	Widow
7	Birth-place	Ultimo, N.S.W.	Lowestoft, England.
8	Age (years)	56 years	52 years
9	Parents— Father's name and Surname. Christian name and Surname.	Alexander Martin Smith (deceased)	George Church (deceased)
	Mother's name and Maiden Surname. Christian name and Maiden Surname.	Blance Howard Moore (deceased)	Grace Emily Pratt (deceased)
10	Father's occupation.	Bookmaker	Builder

Married at Wesley Chapel, Sydney
According to the rites of the Methodist Church

This marriage was solemnized between us—

in the presence of us—

O. Wilkins
M. L. Reeves

B

By me— Alan Walker,
Officiating Minister or Registrar

Received and registered by me this 30th day of December, 1958

J. H. Watson

Registrar General

I, Jack Hayward Watson, Registrar General, do hereby certify that the above is a true copy of the particulars in an entry in a Register kept at the Registrar General's Office, Sydney, New South Wales, and extracted this 14th day of May, 1965.

J. H. Watson



Registrar General.



10.30.85
 20 SEP 1954
 R.P. 13. No. 27597



FEES:— £ s d
 Lodgment : :
 Endorsement : :
 Certificate L: 10
 2/10
 10/18/54

MEMORANDUM OF TRANSFER
 (REAL PROPERTY ACT, 1900.)

I, GRACE MILES of 241 Oxford Street, Bondi Junction, Widow

(herein called transferor)

being registered as the proprietor of an estate in *fee simple* in the land hereinafter described, subject, however, to such encumbrances, liens and interests as are notified hereunder, in consideration of Eight hundred pounds

(£800/-/-) (the receipt whereof is hereby acknowledged) paid to me by

FRED STANLEY CORNISH of 37 St. James Road, Bondi Junction, Builder

and GERTRUDE FLORENCE CORNISH his wife (herein called transferees

do hereby transfer to the said transferees as joint tenants

ALL such my Estate and Interest in ALL THE land mentioned in the schedule following:—

County.	Parish.	Reference to Title (d)			Description of Land (if part only).
		Whole or Part	Vol.	Fol.	
Northumberland	Patonga	Part	2182	69	being lot 7 as shown in D.P. 24978. Being Lot 7 in resubdivision Lot 26 & 27 Section 1.D.P. 6298.

And the transferees covenants with the transferor TOGETHER WITH (as appurtenant to the land hereby transferred) a right of footway over all that piece of land three feet wide along the Eastern boundary of Lot 9 as shown in the said deposited plan AND reserving unto the transferor as appurtenant to Lots 8 and 9 in the said deposited plan a right of carriageway over all that piece of land ten feet wide along the Western boundary of lot 7 as shown in the said deposited plan.

ENCUMBRANCES, &c., REFERRED TO*

Reservations and conditions as are noted on the said Certificate of Title.

Signed at SYDNEY the fourteenth day of July, 1954.

Signed in my presence by the transferor

WHO IS PERSONALLY KNOWN TO ME

R. Ferguson J.P.

Grace Miles
 Transferor.*

Signed

Signed in my presence by the transferees

WHO IS PERSONALLY KNOWN TO ME

R. Ferguson J.P.

F. L. Cornish
G. F. Cornish
 Transferee(s).

We Accepted, and hereby certify this Transfer to be correct for the purposes of the Real Property Act.

* If signed by virtue of any power of attorney, the original power must be registered, and produced with each dealing, and the memorandum of non-revocation on back of form signed by the attorney before a witness.

† N.B.—Section 117 requires that the above Certificate be signed by each Transferor or his Solicitor or Conveyancer, and renders any person falsely or negligently certifying liable to a penalty of £50, also to damages recoverable by parties injured. Acceptance by the Solicitor or Conveyancer (who must sign his own name, and not that of his firm) is permitted only when the signature of the Transferor cannot be obtained without difficulty, and when the instrument does not impose a liability on the party taking under it. When the instrument contains some special covenant by the Transferor or is subject to a mortgage, encumbrance or lease, the Transferee must accept personally.

No alterations should be made by erasure. The words rejected should be scored through with the pen, and those substituted written over them, the alteration being verified by signature or initials in the margin, or noticed in the attestation.

THIS SPACE TO BE LEFT FREE FROM NOTATION

NOT TO BE ALTERED BY ERASURE OR BY FOOT NOTES

(Trusts must not be disclosed in the transfer.)

Typing or handwriting in this instrument should not extend into any margin. Handwriting should be clear and legible, and in permanent black or blue-black ink. The following alterations are permitted:—

- Words may be struck out in the margin, and the instrument may be re-written in the margin.
- Full postal address of transferee must be shown.
- If to two or more, state whether as joint tenants or tenants in common.
- If all the references cannot be conveniently inserted, a form of annexure (obtainable at L.T.O.) may be added. Any annexure must be signed by the parties and their signatures witnessed.
- If part only of the land comprised in a Certificate of Title is to be transferred add "and being lot sec. D.E." or "being the land shown in the plan annexed hereto," or "being the residue of the land in certificate (or grant) registered Vol. Fol. Where the consent of the local council is required to a subdivision, the certificate and plan mentioned in the L.C. Act, 1910, should accompany the transfer. Strike out if unnecessary. Covenants should comply with Section 88 of the Conveyancing Acts, 1919-1941. Here also should be set forth any right-of-way or easement or exception. Any provision in addition to or modification of the covenants implied by the Act may also be inserted. If the space provided is insufficient a form of annexure of the same size and quality of paper as this instrument should be used. A very short note will suffice.

h If executed within the State this instrument should be signed or acknowledged before the Registrar-General, or Deputy Registrar-General, or a Notary Public, a J.P., or Commissioner for Affidavits, to whom the Transferor is known, otherwise the attesting witness should appear before one of the above functionaries who having questioned the witness should sign the certificate on the back of this form. As to instruments executed elsewhere, see back of form.

i Repeat attestation if necessary.

If the Transferor or Transferee signs by a mark, the attestation must state that the instrument was read over and explained to him, and that he appeared fully to understand the same.

New being of land comprised in Cert of Title, Vol. 6883 Fol. 2 & 3

11/14/54
10/18/54

CONSENT OF MORTGAGEE! 63 Elizabeth Street, SYDNEY.
 (N.B.—Before execution read marginal note.)

I, _____ mortgagee under Mortgage No. _____
 release and discharge the land comprised in the within transfer from such mortgage and all claims thereunder but without prejudice to my rights and remedies as regards the balance of the land comprised in such mortgage.

This consent is appropriate only to a transfer of part of the land in the Certificate of Title or Crown Grant. The mortgagee should execute a formal discharge where the land transferred is the whole or the residue of the land in the Certificate of Title or Crown Grant or is the whole of the land in the mortgage.

Dated at SYDNEY this _____ day of _____ 1954.
 Signed in my presence by _____

who is personally known to me. _____
 Mortgagee.

MEMORANDUM AS TO NON-REVOCATION OF POWER OF ATTORNEY.
 (To be signed at the time of executing the within instrument.)

Memorandum whereby the undersigned states that he has no notice of the revocation of the Power of Attorney registered No. _____ Miscellaneous Register under the authority of which he has just executed the within transfer.*

*Strike out unnecessary words. Add any other matter necessary to show that the power is effective.

Signed at _____ the _____ day of _____ 19____
 Signed in the presence of— _____

CERTIFICATE OF J.P., &c., TAKING DECLARATION OF ATTESTING WITNESS!

Appeared before me at _____ the _____ day of _____, one thousand nine hundred and _____ and declared that he personally knew _____ the person signing the same, and whose signature thereto he has attested; and that the name purporting to be such signature of the said _____ is _____ own handwriting, and that he was of sound mind and freely and voluntarily signed the same.

To be signed by Registrar-General, Deputy Registrar-General, a Notary Public, J.P., Commissioner for Affidavits, or other functionary before whom the attesting witness appears. Not required if the instrument itself be signed or acknowledged before one of these parties.

INDEXED	MEMORANDUM OF TRANSFER	DOCUMENTS LODGED HEREWITH. To be filled in by person lodging dealing.	
	Checked by _____ Particulars entered in Register Book. Volume <u>2317</u> Folio <u>137</u> <u>6883</u> - <u>243-244</u> Passed (in S.D.B.) by _____ the <u>31st</u> day of <u>December</u> 19 <u>54</u> Signed by _____ minutes past <u>0</u> o'clock in the _____ Registrar-General.	1 <u>2 CRs</u> } <u>2317/137</u> 2 } <u>2182/69</u> 3 } 4 } 5 } 6 } 7 }	Received Docs. Nos. Receiving Clerk.

LEAVE THESE SPACES FOR DEPARTMENTAL USE.

PROGRESS RECORD.

	Initials.	Date.
Sent to Survey Branch		
Received from Records		
Draft written		
Draft examined		
Diagram prepared		
Diagram examined		
Draft forwarded		
Stpt. of Engrossers		
Cancellation Clerk		
VOL.		FOL.

EXECUTION OUTSIDE NEW SOUTH WALES.
 If the parties be resident without the State, but in any other part of the British Dominions, the instrument must be signed or acknowledged before the Registrar-General or Recorder of Deeds of such Possession, or before any Judge, Notary Public, Justice of the Peace for New South Wales, or Commissioner for taking affidavits for New South Wales, or the Mayor or Chief Officer of any municipal or local government corporation of such part, or Justice of the Peace for such part, or the Governor, Government Resident, or Chief Secretary of such part or such other person as the Chief Justice of New South Wales may appoint.
 If resident in the United Kingdom then before the Mayor or Chief Officer of any corporation or a Notary Public.
 If resident at any foreign place, then the parties should sign or acknowledge before a British Minister, Ambassador, Envoy, Minister, Charge d'Affaires, Secretary of the Embassy or Legation, Consul-General, Consul, Vice-Consul, Acting-Consul, Pro-Consul, or Consular Agent, who should affix his seal of office, or the attesting witness may make a declaration of the due execution thereof before one of such persons (who should sign and affix his seal to such declaration), or such other person as the said Chief Justice may appoint.
 The fees are:—Upon lodgment (a) £1-10-0, if accompanied by the relevant title or evidence of production thereof, (b) £1-15-0 otherwise. This fee includes endorsement on the first Certificate. In addition the following fees are payable:—(a) 5/- for each additional Certificate included in the Transfer, (b) £2 for each new Certificate of Title issued, (c) 10/- where the Transfer contains covenant purporting to affect the user of any land, (d) 10/- where the Transfer is expressed to be made together with an easement or expressed to reserve an easement or in any way creates an easement, (e) 10/- where partial discharge of a mortgage is endorsed on the Transfer, (f) 2/6 for each additional folio where the Certificate exceeds fifteen folios, (g) as approved, in cases involving more than one simple diagram or any diagram other than a simple diagram.
 Tenants in common must receive separate Certificates.
 If part only of the land is transferred a new Certificate must issue for that part, and the old Certificate will be retained in the Office. A new Certificate may be taken out for the residue if desired.

Tonkin Drysdale Partners - Woy Woy
79 Blackwall Rd
WOY WOY NSW 2256

SECTION 10.7(2) AND (5) PLANNING CERTIFICATE

Under Section 10.7 of the Environmental Planning and Assessment Act, 1979

Fee paid:	\$178.00
Receipt No:	22969988
Receipt Date:	21 August 2025
Property Address:	372 Ocean View Road, ETTALONG BEACH NSW 2257
Property Description:	Lot 9 DP 24978
Property Owner	T Totaro and M Totaro
Certificate No:	89758
Reference No:	SP:2231536:325323
Date of issue:	22-Aug-2025

The information contained within this certificate relates to the land.

**ADVICE PROVIDED PURSUANT TO S.10.7(2) OF THE ENVIRONMENTAL
PLANNING AND ASSESSMENT ACT 1979**

1	NAMES OF RELEVANT PLANNING INSTRUMENTS AND DEVELOPMENT CONTROL PLANS
----------	---

(1) Environmental Planning Instruments and Development Control Plans that applies to the carrying out of development on the land

Central Coast Local Environmental Plan 2022

Central Coast Development Control Plan 2022

State Environmental Planning Policy (Primary Production) 2021
State Environmental Planning Policy (Transport and Infrastructure) 2021
State Environmental Planning Policy (Biodiversity and Conservation) 2021
State Environmental Planning Policy (Resilience and Hazards) 2021
State Environmental Planning Policy (Industry and Employment) 2021
State Environmental Planning Policy (Resources and Energy) 2021
State Environmental Planning Policy (Planning Systems) 2021
State Environmental Planning Policy (Housing) 2021
State Environmental Planning Policy (Exempt and Complying Development Codes) 2008
State Environmental Planning Policy (Sustainable Buildings) 2022

(2) Proposed Environmental Planning Instruments and Draft Development Control Plans which is or has been subject to community consultation or public exhibition under the Act, that will apply to the carrying out of development on the land

Proposed State Environmental Planning Policy (Transport and Infrastructure) 2021
Proposed State Environmental Planning Policy (Housing) 2021
Proposed State Environmental Planning Policy (Planning Systems) 2021
Proposed Cultural State Environmental Planning Policy
Proposed State Environmental Planning Policy (Exempt & Complying Development Codes) 2008
Proposed Standard Instrument (Local Environmental Plans) Order 2006

2	ZONING AND LAND USE UNDER RELEVANT PLANNING INSTRUMENTS
----------	--

(a) Identity of the Zone

Lot 9 DP 24978
R1 General Residential

(b) For each of the environmental planning instruments referred to in clause 1, please refer to the attached land use table to determine (i), (ii) and (iii) listed below:

- (i) development that may be carried out within the zone without the need for development consent,
- (ii) development which may not be carried out within the zone except with development consent and
- (iii) development which is prohibited within the zone.

(c) Whether additional permitted uses apply to the land

Additional Permitted Uses **do not** apply to this land.

(d) Whether development standards applying to the land fix minimum land dimensions for the erection of a dwelling-house on the land and, if so, the fixed minimum land dimensions

There are no development standards applying to the land that fix minimum land dimensions for the erection of a dwelling-house on the land. However there are minimum lot sizes applying to the subdivision of land, and in some zones the entitlement to erect a dwelling-house, or carry out other types of residential development, is linked to that minimum lot size.

(e) Whether the land is in an area of outstanding biodiversity value under the *Biodiversity Conservation Act 2016*

No

(f) Whether the land is in a conservation area, however described

No

(g) Whether an item of environmental heritage, however described, is located on the land

None

3	CONTRIBUTION PLANS
----------	---------------------------

Contributions Plan No. 31A - Drainage - Peninsula

Contributions Plan No. 31B - Road Works - Peninsula

Contributions Plan No. 31C - Open Space & Recreation - Peninsula

Contributions Plan No. 31D - Community Facilities & Community Services - Peninsula

The subject land is within Central Coast to which the *Environmental Planning and Assessment (Housing and Productivity Contribution) Order 2023* applies.

This land is subject to the Central Coast Section 7.12 Local Infrastructure Contribution Plan 2023

The land is subject to the Draft Central Coast Section 7.12 Local Infrastructure Contributions Plan 2024

4	COMPLYING DEVELOPMENT
----------	------------------------------

Whether or not the land is land on which complying development may be carried out under each of the complying development codes under the *State Environmental Planning Policy (Exempt and Complying Development Codes) 2008*, because of that Policy, clause 1.17A(1)(c)–(e), (2), (3) or (4), 1.18(1)(c3) and 1.19.

HOUSING CODE

Complying Development under the Housing Code **may** be carried out on the land. This information needs to be read in conjunction with the whole of the State Environmental Planning Policy (Exempt and Complying Development Codes) 2008.

RURAL HOUSING CODE

Complying development under the Rural Housing Code **may** be carried out on the land. This information needs to be read in conjunction with the whole of the State Environmental Planning Policy (Exempt and Complying Development Codes) 2008.

LOW RISE HOUSING DIVERSITY CODE

Complying Development under the Low Rise Housing Diversity Code **may** be carried out on the land. This information needs to be read in conjunction with the whole of the State Environmental Planning Policy (Exempt and Complying Development Codes) 2008.

PATTERN BOOK DEVELOPMENT CODE

Complying development under the Pattern Book Development Code **may** be carried out on the land. This information needs to be read in conjunction with the whole of the *State Environmental Planning Policy (Exempt and Complying Development Codes) 2008*.

GREENFIELD HOUSING CODE

Greenfield Housing Code **is not** applicable to this land.

HOUSING ALTERATIONS CODE

Complying development under the Housing Alterations Code **may** be carried out on the land. This information needs to be read in conjunction with the whole of the State Environmental Planning Policy (Exempt and Complying Development Codes) 2008.

GENERAL DEVELOPMENT CODE

Complying development under the General Development Code **may** be carried out on the land. This information needs to be read in conjunction with the whole of the State Environmental Planning Policy (Exempt and Complying Development Codes) 2008.

INDUSTRIAL AND BUSINESS ALTERATIONS CODE

Complying development under the Industrial and Business Alterations Code **may** be carried out on the land. This information needs to be read in conjunction with the whole of the State Environmental Planning Policy (Exempt and Complying Development Codes) 2008.

INDUSTRIAL AND BUSINESS BUILDINGS CODE

Complying development under the Industrial and Business Buildings Code **may** be carried out on the land. This information needs to be read in conjunction with the whole of the State Environmental Planning Policy (Exempt and Complying Development Codes) 2008.

CONTAINER RECYCLING FACILITIES CODE

Complying Development under the Container Recycling Facilities Code **may** be carried out on the land. This information needs to be read in conjunction with the whole of the State Environmental Planning Policy (Exempt and Complying Development Codes) 2008.

SUBDIVISIONS CODE

Complying Development under the Subdivisions Code **may** be carried out on the land. This information needs to be read in conjunction with the whole of the *State Environmental Planning Policy (Exempt and Complying Development Codes) 2008*.

DEMOLITION CODE

Complying development under the Demolition Code **may** be carried out on the land. This information needs to be read in conjunction with the whole of the State Environmental Planning Policy (Exempt and Complying Development Codes) 2008.

FIRE SAFETY CODE

Complying development under the Fire Safety Code **may** be carried out on the land. This information needs to be read in conjunction with the whole of the State Environmental Planning Policy (Exempt and Complying Development Codes) 2008.

AGRITOURISM AND FARM STAY ACCOMMODATION CODE

Complying development under the Agricultural and Farm Stay Accommodation Code **may** be carried out on the land. This information needs to be read in conjunction with the whole of the *State Environmental Planning Policy (Exempt and Complying Development Codes) 2008*.

5	EXEMPT DEVELOPMENT
----------	---------------------------

Whether or not the land is land on which exempt development may be carried out under each of the exempt development codes under *State Environmental Planning Policy (Exempt and Complying Development Codes) 2008* because of that Policy, clause 1.16(1) (b1)–(d) or 1.16A.

GENERAL EXEMPT DEVELOPMENT CODE

Exempt development under the General Exempt Development Code applies to this land. This information needs to be read in conjunction with the whole of the *State Environmental Planning Policy (Exempt and Complying Development Codes) 2008*.

ADVERTISING AND SIGNAGE EXEMPT DEVELOPMENT CODE

Exempt development under the Advertising and Signage Exempt Development Code applies to this land. This information needs to be read in conjunction with the whole of the *State Environmental Planning Policy (Exempt and Complying Development Codes) 2008*.

TEMPORARY USES AND STRUCTURES EXEMPT DEVELOPMENT CODE

Exempt development under the Temporary Uses and Structures Exempt Development Code applies to this land. This information needs to be read in conjunction with the whole of the *State Environmental Planning Policy (Exempt and Complying Development Codes) 2008*.

6	AFFECTED BUILDING NOTICES AND BUILDING PRODUCT RECTIFICATION ORDERS (<i>BUILDING PRODUCT SAFETY ACT 2017</i>)
----------	--

1(a) Is there any affected building notice of which the council is aware that is in force in respect of the land?

No

1(b) Is there any building product rectification order of which the council is aware that is in force in respect of the land and has not been fully complied with?

No

1(c) Is there any notice of intention to make a building product rectification order of which the council is aware has been given in respect of the land and is outstanding?

No

In this section—

affected building notice has the same meaning as in the *Building Products (Safety) Act 2017*, Part 4.

building product rectification order has the same meaning as in the *Building Products (Safety) Act 2017*

7	LAND RESERVED FOR ACQUISITION
----------	--------------------------------------

Whether an environmental planning instrument or proposed environmental planning instrument referred to in section 1 makes provision in relation to the acquisition of the land by an authority of the State, as referred to in the Act, section 3.15.

Nil

8	ROAD WIDENING AND ROAD ALIGNMENT
----------	---

(a) DIVISION 2 OF PART 3 OF THE *ROADS ACT 1993*

The land is not affected by road realignment or road widening under the above.

(b) ENVIRONMENTAL PLANNING INSTRUMENT

The land is not affected by road realignment or road widening under the above.

(c) COUNCIL RESOLUTIONS

The land is not affected by road realignment or road widening under the above.

9	FLOOD RELATED DEVELOPMENT CONTROLS
----------	---

(1) The land or part of the land **is** within the flood planning area and **is** subject to flood related development controls.

(2) The land or part of the land **is** between the flood planning area and the probable maximum flood and **is** subject to flood related development controls.

(3) In this section—

flood planning area has the same meaning as in the Floodplain Development Manual.

Floodplain Development Manual means the Floodplain Development Manual (ISBN 0 7347 5476 0) published by the NSW Government in April 2005.

probable maximum flood has the same meaning as in the Floodplain Development

Manual.

10	COUNCIL AND OTHER PUBLIC AUTHORITY POLICIES ON HAZARD RISK RESTRICTIONS
-----------	--

This land is affected by a policy adopted by the council or other public authority that restricts the development of the land because of the likelihood of risk restrictions. This land is affected because:

The subject property has been identified as being Class 3 - (Works beyond 1 metre below the natural ground surface; Works by which the watertable is likely to be lowered beyond 1 metre below natural surface) on the Acid Sulfate Soil Planning Maps held by Council.

Chapter 3.7 Geotechnical Requirements of Central Coast Development Control Plan 2022 applies to the land and the land may be subject to slip. When considering a development application, each circumstance will be considered, and development may be restricted.

In this section—

adopted policy means a policy adopted—

- (a) by the council, or
- (b) by another public authority, if the public authority has notified the council that the policy will be included in a planning certificate issued by the council.

11	BUSH FIRE PRONE LAND
-----------	-----------------------------

The information currently available to Council indicates that this land is **not** bushfire prone land (as defined in the Act).

12	LOOSE-FILL ASBESTOS INSULATION
-----------	---------------------------------------

This land does not include any residential premises (within the meaning of the *Home Building Act 1989*, Part 8, Division 1A) that are listed on the register that is required to be maintained under that Division. That register lists residential premises that contain or have contained loose-fill asbestos insulation.

13	MINE SUBSIDENCE
-----------	------------------------

The land **IS NOT WITHIN** a Mine Subsidence District declared under section 20 of the *Coal Mine Subsidence Compensation Act 2017*.

14	PAPER SUBDIVISION INFORMATION
-----------	--------------------------------------

- (1) The name of any development plan adopted by a relevant authority that:
 - (a) applies to this land or
 - (b) that is proposed to be subject to a consent ballot.

Nil

- (2) The date of any subdivision order that applies to this land.

Not applicable

Words and expressions used in this section have the same meaning as in this Regulation, Part 10 and the Act, Schedule 7.

15	PROPERTY VEGETATION PLANS
-----------	----------------------------------

Council **has not** been notified by Local Land Services – Greater Sydney that the land is subject to a property vegetation plan approved under Part 4 of the Native Vegetation Act 2003.

16	BIODIVERSITY STEWARDSHIP SITES
-----------	---------------------------------------

Council **has not** been notified by the Biodiversity Conservation Trust that the land is a biodiversity stewardship site under a biodiversity stewardship agreement under Part 5 of the *Biodiversity Conservation Act, 2016*.

Note: Biodiversity stewardship agreements include biobanking agreements under the *Threatened Species Conservation Act 1995*, Part 7A that are taken to be biodiversity stewardship agreements under the *Biodiversity Conservation Act 2016*, Part 5.

17	BIODIVERSITY CERTIFIED LAND
-----------	------------------------------------

The land **is not** biodiversity certified land within the meaning of Part 8 of the *Biodiversity Conservation Act, 2016*.

Note: Biodiversity certified land includes land certified under the *Threatened Species Conservation Act 1995*, Part 7AA that is taken to be certified under the *Biodiversity Conservation Act 2016*, Part 8.

18	ORDERS UNDER TREES (DISPUTES BETWEEN NEIGHBOURS) ACT 2006
-----------	--

Council **has not** been notified of an Order issued under the *Trees (Disputes between Neighbours) Act 2006*.

NOTE: This advice is based on information provided by the Land and Environment Court

19	ANNUAL CHARGES UNDER LOCAL GOVERNMENT ACT 1993 FOR COASTAL PROTECTION SERVICES THAT RELATE TO EXISTING COASTAL PROTECTION WORKS
-----------	--

The owner (or any previous owner) of the land has not consented in writing to the land being subject to annual charges under section 496B of the *Local Government Act 1993* for coastal protection services that relate to existing coastal protection works.

In this section—

existing coastal protection works has the same meaning as in the *Local Government Act 1993*, section 553B.

Note—

Existing coastal protection works are works to reduce the impact of coastal hazards on land, such as seawalls, revetments, groynes and beach nourishment, that existed before 1 January 2011.

20	WESTERN SYDNEY AEROTROPOLIS
-----------	------------------------------------

Not applicable to Central Coast Local Government Area

21	DEVELOPMENT CONSENT CONDITIONS FOR SENIORS HOUSING
-----------	---

Council is **not** aware of there being a current Site Compatibility Certificate (seniors housing) issued by the Director-General of the Department of Planning and Environment in respect of the land.

NOTE: This advice is based on information provided by the NSW Department of Planning and Environment.

22	SITE COMPATIBILITY CERTIFICATES AND DEVELOPMENT CONSENT CONDITIONS FOR AFFORDABLE RENTAL HOUSING
-----------	---

Council is **not** aware of there being a valid Site Compatibility Certificate (affordable rental housing) issued by the Director-General of the Department of Planning and Environment in respect of the land.

NOTE: This advice is based on information provided by the NSW Department of Planning and Environment.

23	WATER OR SEWERAGE SERVICES
-----------	-----------------------------------

Water or sewerage services provided to the land are not under the *Water Industry Competition Act 2006*.

Note—

A public water utility may not be the provider of some or all of the services to the land. If a water or sewerage service is provided to the land by a licensee under the *Water Industry Competition Act 2006*, a contract for the service will be deemed to have been entered into between the licensee and the owner of the land. A register relating to approvals and licences necessary for the provision of water or sewerage services under the *Water Industry Competition Act 2006* is maintained by the Independent Pricing and Regulatory Tribunal and

provides information about the areas serviced, or to be serviced, under that Act. Purchasers should check the register to understand who will service the property. Outstanding charges for water or sewerage services provided under the *Water Industry Competition Act 2006* become the responsibility of the purchaser.

24	SPECIAL ENTERTAINMENT PRECINCTS
-----------	--

Whether the land or part of the land is in a special entertainment precinct within the meaning of the *Local Government Act 1993*, section 202B.

No

NOTE

CONTAMINATED LAND MANAGEMENT ACT 1997

The following matters are prescribed by section 59 (2) of the *Contaminated Land Management Act 1997* as additional matters to be specified in a planning certificate:

- (a) The land to which the certificate relates is significantly contaminated land within the meaning of that Act - if the land (or part of the land) is significantly contaminated land at the date when the certificate is issued,

No
- (b) The land to which the certificate relates is subject to a management order within the meaning of that Act - if it is subject to such an order at the date when the certificate is issued,

No
- (c) The land to which the certificate relates is the subject of an approved voluntary management proposal within the meaning of that Act - if it is the subject of such an approved proposal at the date when the certificate is issued,

No
- (d) The land to which the certificate relates is subject to an ongoing maintenance order within the meaning of that Act - if it is subject to such an order at the date when the certificate is issued,

No
- (e) The land to which the certificate relates is the subject of a site audit statement within the meaning of that Act - if a copy of such a statement has been provided at any time to the local authority issuing the certificate.

No

**ADVICE PROVIDED PURSUANT TO S.10.7(5) OF THE ENVIRONMENTAL
PLANNING AND ASSESSMENT ACT 1979**

NOTE: SECTION 10.7(6) OF THE ACT STATES THAT A COUNCIL SHALL NOT INCUR ANY LIABILITY IN RESPECT OF ANY ADVICE PROVIDED IN GOOD FAITH PURSUANT TO SUBSECTION (5).

For any enquiries regarding this Certificate, please contact Council's Customer Contact Centre on 02 4306 7900.

Signed on Behalf of Central Coast Council

LAND USE TABLE

Zone R1 General Residential Central Coast Local Environmental Plan 2022

1 Objectives of zone

- To provide for the housing needs of the community.
- To provide for a variety of housing types and densities.
- To enable other land uses that provide facilities or services to meet the day to day needs of residents.
- To promote best practice in the design of multi dwelling housing and other similar types of development.
- To ensure that non-residential uses do not adversely affect residential amenity or place unreasonable demands on services.

2 Permitted without consent

Home occupations; Recreation areas

3 Permitted with consent

Attached dwellings; Bed and breakfast accommodation; Boarding houses; Boat launching ramps; Boat sheds; Car parks; Caravan parks; Centre-based child care facilities; Community facilities; Dual occupancies; Dwelling houses; Educational establishments; Emergency services facilities; Environmental facilities; Environmental protection works; Exhibition homes; Exhibition villages; Flood mitigation works; Group homes; Home-based child care; Home businesses; Home industries; Home occupations (sex services); Hostels; Hotel or motel accommodation; Information and education facilities; Jetties; Multi dwelling housing; Neighbourhood shops; Oyster aquaculture; Places of public worship; Pond-based aquaculture; Residential flat buildings; Respite day care centres; Roads; Secondary dwellings; Semi-detached dwellings; Seniors housing; Serviced apartments; Sewage reticulation systems; Shop top housing; Signage; Tank-based aquaculture; Water recycling facilities; Water reticulation systems; Water storage facilities

4 Prohibited

Any development not specified in item 2 or 3



ABN 73 149 644 003

Your Ref: SP:2231536:258053

16 October 2023

Tonkin Drysdale Partners - Woy Woy
79 Blackwall Rd
WOY WOY NSW 2256

Dear Sir/Madam

**372 Ocean View Road, ETTALONG BEACH NSW 2257
Lot 9 DP 24978**

In reply to your request for an internal sewerage connection plan for the above lot, please find enclosed your copy of this plan.

Should you require any further information regarding this matter, please contact Central Coast Council's Customer Services Section on 02 4306 7900.

Yours faithfully

A handwritten signature in black ink, consisting of the letters "MW" followed by a long horizontal line.

M Walsh
Signed on Behalf of Central Coast Council

Attachment:



Wyong Office: 2 Hely St / PO Box 20 Wyong NSW 2259 | P 02 4306 7900

Gosford Office: 91-99 Mann Street, Gosford – P: 02 4306 7900

E ask@centralcoast.nsw.gov.au | W www.centralcoast.nsw.gov.au | ABN 73 149 644 003

372 Ocean View Road, ETTALONG BEACH NSW 2257
 Lot 9 DP 24978



THIS PLAN IS DIAGRAMMATIC ONLY
 DISTANCES SCALED FROM THIS PLAN MAY NOT BE ACCURATE

GOSFORD CITY COUNCIL

No. 201864

SEWERAGE CONNECTION PLAN

OWNER LARCOMBE, ... HOUSE No. 372 ...
 LOT 9 ... SEC ... D.P. 24978 ...
 STREET OCEAN VIEW ROAD ...
 DISTRICT ETTALONG ...

All plumbing and draining work must be carried out in accordance with
 the provisions of Ordinance No. 46, Local Government Act, 1919,
 and to the satisfaction of the Council.

RAIN OR SURFACE WATER IS NOT TO BE CONNECTED TO THE SEWER

SYMBOLS AND ABBREVIATIONS

- | | | | |
|--------------------|-----------------------|----------------|-------------------|
| □ Boundary Trap | RV Reflux Valve | T Tube | H Basin |
| ⊕ Inspection Shaft | IO Inspection opening | K Kitchen Sink | S Shower |
| ⊖ Pit | vVert Vertical pipe | W Water Closet | F Floor Waste |
| ⊗ Gully | vV Vent pipe | B Bath Waste | M Washing Machine |
| | sV Soil Vent pipe | WS Waste Stack | |

SCALE 1:500

Distances/Depths in metres; Pipe diameters in millimetres

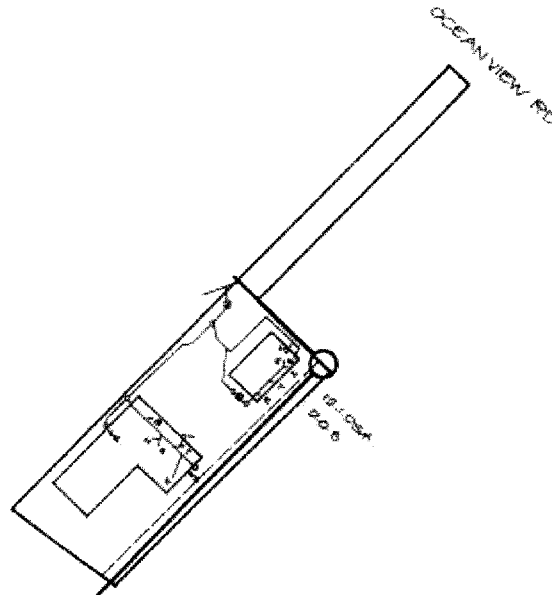

DRAINAGE - Supervised by S. SINCLAIR	DATE	PLUMBER / PATAIC ...
	16/10/21	
PLUMBING - Supervised by ...		
DRAWN BY - C. KIRBY		



ABN 73 149 644 003
16 October 2023

Tonkin Drysdale Partners - Woy Woy
79 Blackwall Rd
WOY WOY NSW 2256

Dear Sir/Madam

Property: Lot 9 DP 24978
372 Ocean View Road, ETTALONG BEACH NSW 2257
Your Reference: SP:2231536:258053

Reference is made to your request for a Sewer Mains Diagram.

In this regard please now find attached a copy of the relevant information showing the sewer main/s location in relation to the property.

If you have any further enquiries regarding this diagram, please contact Central Coast Council's Customer Contact on 02 4306 7900.

Yours faithfully

A handwritten signature in black ink, appearing to be "M Walsh", with a horizontal line extending to the right.

M Walsh
Signed on Behalf of Central Coast Council

Attach



Wyong Office: 2 Hely St / PO Box 20 Wyong NSW 2259 | P 02 4306 7900
Gosford Office: 91-99 Mann Street, Gosford – P: 02 4306 7900
E ask@centralcoast.nsw.gov.au | W www.centralcoast.nsw.gov.au | ABN 73 149 644 003

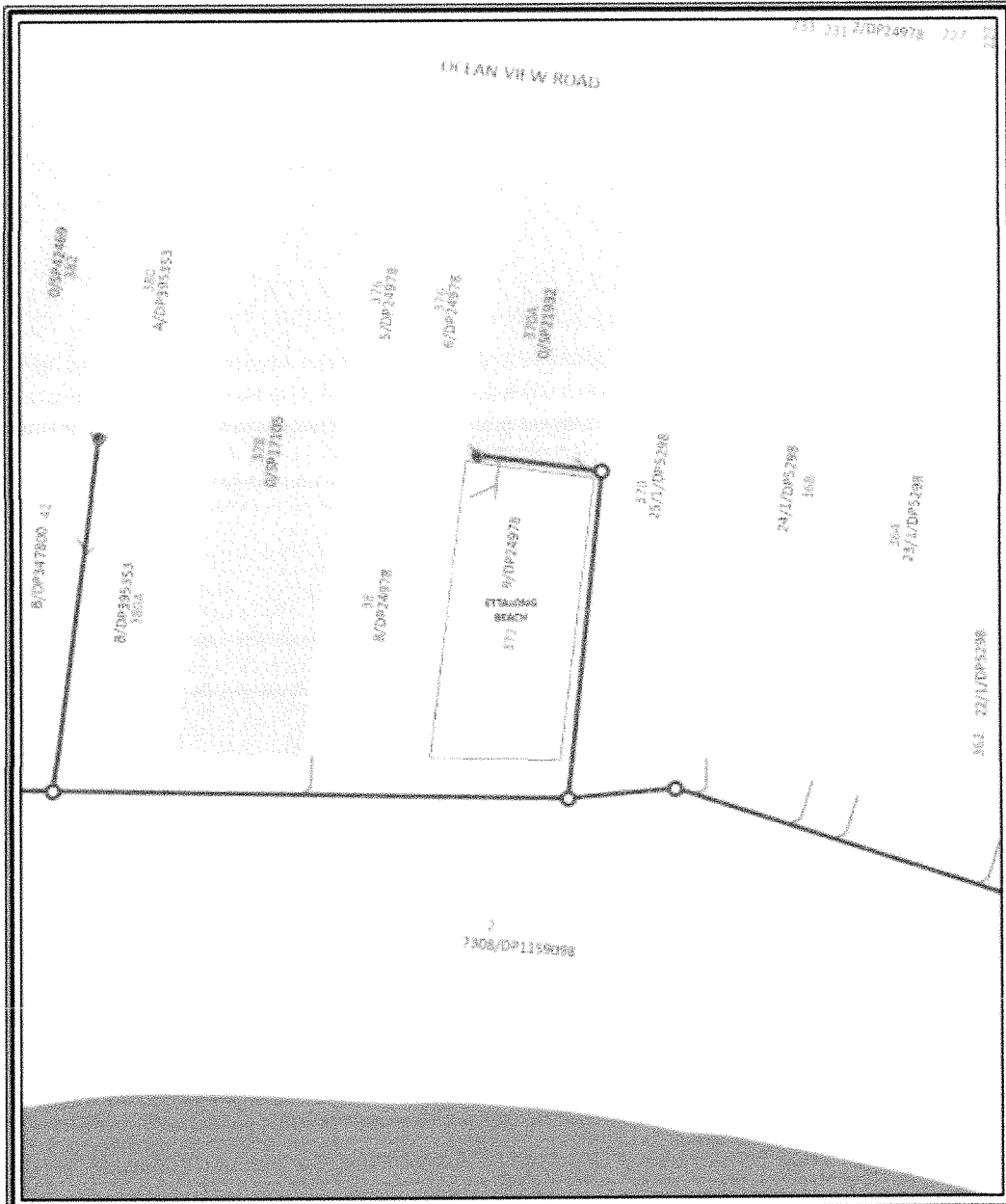

Warning Note for Underground Plant Locations

This plan may not have been updated to take into account changes to standards, when types of plants are substituted for the remainder of the network. This plan is not a warranty, and all measurements are approximate only. The services, including any proposed or yet to be installed, to the water and sewer system of the plan, shown as a standard or as a separate system, of the network, the final position and depth of the services, should be confirmed prior to any excavation. Council can provide an on-site advisory service or engineering report to this effect. Property undergoing work will be held responsible for any damage caused to a third party's property, installation or equipment caused or made as a result of this.

Each customer is part of the Council's overall decision-making process. The Council and Property Management, in consultation with the Department of Finance and Services, may reserve the right to refuse, in writing, or to alter any financial arrangements shown on this plan should they deem it necessary for compliance with the Council's financial and service delivery strategy.

Central Coast Council
Sewer Mains Diagram
 Not to Scale
 Issue Date: 16/10/2023

Legend

	Access Chamber		Reduced Man (Arched)
	Benching		Flow Controller
	Lamp pole		Private Pump Man
	Sewer Manhole		Wing Man
	Valve		Vacuum Man
	Private Pump Station		Water Pump Man Accessory
	Pump Station		Water Encasement
	Treatment Plant		Accessed Man
	Reduction Man		Start Man in Gas
	Truck Man		Applicant Land



RESIDENTIAL TENANCY AGREEMENT

RESIDENTIAL TENANCIES REGULATION 2019



IMPORTANT INFORMATION

Please read this before completing the residential tenancy agreement (the **Agreement**).

1. This form is your written record of your tenancy agreement. This is a binding contract under the *Residential Tenancies Act 2010*, so please read all terms and conditions carefully.
2. If you need advice or information on your rights and responsibilities, please call NSW Fair Trading on 13 32 20 or visit www.fairtrading.nsw.gov.au before signing the Agreement.
3. If you require extra space to list additional items and terms, attach a separate sheet. All attachments should be signed and dated by both the landlord or the landlord's agent and the tenant to show that both parties have read and agree to the attachments.
4. The landlord or the landlord's agent must give the tenant a copy of the signed Agreement and any attachments, two copies or one electronic copy of the completed condition report and a copy of NSW Fair Trading's Tenant Information Statement publication.

This agreement is made on 27 / 06 / 2025 at Ettalong Beach NSW Between

Landlord

[Insert name and telephone number or other contact details of landlord(s). If the landlord does not ordinarily reside in New South Wales, specify the State, Territory or, if not in Australia, country in which the landlord ordinarily resides]

Landlord 1 Name: Marcello Totaro A.B.N. (if applicable):

Landlord telephone number or other contact details: marctotaro9@gmail.com

If not in NSW, the State, Territory or country (if not Australia) the landlord ordinarily resides in:

Note. These details must be provided for landlord(s), whether or not there is a landlord's agent.

[Insert name and telephone number or other contact details of landlord(s). If the landlord does not ordinarily reside in New South Wales, specify the State, Territory or, if not in Australia, country in which the landlord ordinarily resides]

Landlord 2 Name: Tommaso Totaro A.B.N. (if applicable):

Landlord telephone number or other contact details:

If not in NSW, the State, Territory or country (if not Australia) the landlord ordinarily resides in:

Note. These details must be provided for landlord(s), whether or not there is a landlord's agent.

[Insert business address or residential address of landlord(s)]

4/47-49 The Esplanade

Ettalong Beach 2257

Note. These details must be provided for landlord(s) if there is no landlord's agent.

[Insert corporation name and business address of landlord(s) if landlord(s) is a corporation]

Tenant *[insert name of tenant(s) and contact details]*

Tenant 1 Name Ashlee Curran

Phone

Email Ashlee1044@gmail.com

Tenant 2 Name

Phone

Email

Tenant 3 Name

Phone

Email

Tenant 4 Name

Phone

Email

Property Address: 1/372 Ocean View Road, Ettalong Beach, NSW, 2257

COPYRIGHT MAY 2025

Originated and distributed by and printed and produced for the Real Estate Institute of N.S.W. in whom exclusive copyright vests.

WARNING Unauthorised reproduction in whole or in part is an infringement of Copyright.

000007246866



RESIDENTIAL TENANCY AGREEMENT



Landlord's agent details *[Insert name of landlord's agent (if any) and contact details]*

Licensee Mi Property Group Pty Ltd ATF Mi Property Unit Trust			
Trading as Stone Real Estate Ettalong Beach		A.B.N. 54 640 724 874	
Address Shop 4			
47-49 The Esplanade, ETTALONG BEACH, NSW		Postcode 2257	
Phone 024369-6000	Fax	Mobile 0499 990 374	Email christineglass@stonerealestate.com.au

Tenant's agent details *[Insert name of tenant's agent (if any) and contact details]*

Name /s		A.B.N.	
Address			
Postcode			
Phone	Fax	Mobile	Email

Term of agreement

The term of this agreement is:

- 6 months
- 12 months
- 2 years
- 3 years
- 5 years
- Other (please specify):
- Periodic (no end date)

starting on and ending on *[Cross out if not applicable]*

Note. For a residential tenancy agreement having a fixed term of more than 3 years, the agreement must be annexed to the form approved by the Registrar-General for registration under the *Real Property Act 1900*.

Residential Premises

The residential premises are *[Insert address]*

Address 1/372 Ocean View Road		
Suburb Ettalong Beach	State NSW	Postcode 2257

The residential premises include: *[Include any inclusions, for example, a parking space or furniture provided. Attach additional pages if necessary.]*

Fully furnished, electricity and water usage
--

The residential premises **do not include:** *[List anything such as a parking space, garage or storeroom which do not form part of the residential premises]*

--

Property Address:



RESIDENTIAL TENANCY AGREEMENT



Rent

Rent is \$ 550.00

Rent must be paid per week fortnight other (insert description of payment frequency)

Day rent must be paid:

Date first rent payment is due: 29 /07 /2025

Note: The landlord, or landlord's agent, must not require a tenant to pay more than 2 weeks rent in advance under this agreement.

Rent must be paid by:

approved electronic bank transfer (such as direct debit, bank transfer or BPAY)

Centrepay

other:

Note. The landlord, or landlord's agent, must offer the tenant the ability to pay rent by an approved electronic bank transfer method. The electronic bank transfer method must be free of charge to the tenant, other than charges ordinarily imposed by the tenant's bank. From a date notified in the Gazette by the Minister for Better Regulation and Fair Trading, the landlord, or landlord's agent, must also offer the tenant the ability to pay rent by Centrepay.

The landlord and the tenant may agree on a different payment method. The landlord must not require the tenant to use a specific service provider to pay rent.

Details of payment method:

(a) into the following account, Stone Real Estate Ettalong Beach or any other account nominated by the landlord:

BSB number: 082-574 Account number: 877013182

Account name: Mi Property Group Pty Ltd Unit Trust

Payment reference: 101430, or

(b) by BPAY® in accordance with the biller code and reference number below or as otherwise provided to the tenant for that purpose:

BPAY® Biller Code:

Reference Number:

(c) as follows:

Note. The landlord or landlord's agent must not charge a fee, or pass on a cost incurred by the landlord or landlord's agent, for the payment of rent by an approved electronic bank transfer method or by Centrepay.

Rental bond *[Cross out if there is not going to be a bond]*

A rental bond of \$already held must be paid by the tenant on signing this agreement.

The amount of the rental bond must not be more than 4 weeks rent.

The tenant provided the rental bond amount to:

the landlord or another person, or

the landlord's agent, or

NSW Fair Trading through Rental Bonds Online.

Note. All rental bonds must be lodged with NSW Fair Trading. If the bond is paid to the landlord or another person, it must be deposited within 10 working days after it is paid using the Fair Trading approved form. If the bond is paid to the landlord's agent, it must be deposited within 10 working days after the end of the month in which it is paid.

IMPORTANT INFORMATION

Maximum number of occupants

No more than Two persons may ordinarily live in the premises at any one time.

Urgent repairs

Nominated tradespeople for urgent repairs:

Electrical repairs: Toner Electrical Telephone: 0413 408 081

Plumbing repairs: Pro Coast Plumbing Telephone: 0423 643 054

Other repairs: Featon Locksmiths Telephone: 0401 263 273

Property Address: 1/372 Ocean View Road, Ettalong Beach, NSW, 2257

Water usage

Will the tenant be required to pay separately for water usage? Yes No If yes, see clauses 12 and 13.

Utilities

Is electricity supplied to the premises from an embedded network?

Yes No

Is gas supplied to the premises from an embedded network?

Yes No

For more information on consumer rights if electricity or gas is supplied from an embedded network contact NSW Fair Trading.

Smoke alarms

Indicate whether the smoke alarms installed in the residential premises are hardwired or battery operated:

Hardwired smoke alarm

Battery operated smoke alarm

If the smoke alarms are battery operated, are the batteries in the smoke alarms of a kind the tenant can replace?

Yes No

If yes, specify the type of battery that needs to be used if the battery in the smoke alarm needs to be replaced:

If the smoke alarms are hardwired, are the back-up batteries in the smoke alarms of a kind the tenant can replace?

Yes No

If yes, specify the type of back-up battery that needs to be used if the back-up battery in the smoke alarm needs to be replaced:

240v

If the *Strata Schemes Management Act 2015* applies to the residential premises, is the owners corporation of the strata scheme responsible for the repair and replacement of smoke alarms in the residential premises?

Yes No

Strata by-laws

Are there any strata or community scheme by-laws applicable to the residential premises? Yes No If yes, see clauses 38 and 39.

Giving notices and other documents electronically [optional] [Cross out if not applicable]

Indicate below for each person whether the person provides express consent to any notice and any other document under section 223 of the *Residential Tenancies Act 2010* being given or served on them by email. The *Electronic Transactions Act 2000* applies to notices and other documents you send or receive electronically.

[You should only consent to electronic service if you check your emails regularly. If there is more than one tenant on the agreement, all tenants should agree on a single email address for electronic service. This will help ensure co-tenants receive notices and other documents at the same time.]

Landlord

Does the landlord give express consent to the electronic service of notices and documents? Yes No If yes, see clause 50.

[Specify email address to be used for the purpose of serving notices and documents.]

christineglass@stonerealestate.com.au

Tenant

Does the tenant give express consent to the electronic service of notices and documents? Yes No If yes, see clause 50.

[Specify email address to be used for the purpose of serving notices and documents.]

Ashlee1044@gmail.com

Condition report

A condition report relating to the condition of the premises must be completed by or on behalf of the landlord before or when this agreement is given to the tenant for signing.

Tenancy laws

The *Residential Tenancies Act 2010* and the *Residential Tenancies Regulation 2019* apply to this agreement. Both the landlord and the tenant must comply with these laws.

Property Address: 1/372 Ocean View Road, Ettalong Beach, NSW, 2257

RIGHT TO OCCUPY THE PREMISES

1. **The landlord agrees** that the tenant has the right to occupy the residential premises during the tenancy. The residential premises include the additional things (if any) noted under "**Residential premises**".

COPY OF AGREEMENT

2. **The landlord agrees** to give the tenant:
 - 2.1 a copy of this agreement before or when the tenant gives the signed copy of the agreement to the landlord or landlord's agent, and
 - 2.2 a copy of this agreement signed by both the landlord and the tenant as soon as is reasonably practicable.

RENT

3. **The tenant agrees:**
 - 3.1 to pay rent on time, and
 - 3.2 to reimburse the landlord for the cost of replacing rent deposit books or rent cards lost by the tenant, and
 - 3.3 to reimburse the landlord for the amount of any fees paid by the landlord to a bank or other authorised deposit-taking institution as a result of funds of the tenant not being available for rent payment on the due date, and
 - 3.4 that the rent payment method may only be changed by agreement between the landlord and the tenant.
4. **The landlord agrees:**
 - 4.1 to not require the tenant to pay more than 2 weeks rent in advance or to pay rent for a payment period before the end of the previous payment period, and
 - 4.2 to offer the tenant the option to pay rent by an approved electronic bank transfer method or by Centrepay and, if chosen by the tenant, to enable payment by that method, and
 - 4.3 to not charge fees or pass on costs incurred for the payment of rent by an approved electronic bank transfer method or by Centrepay, and
 - 4.4 that the rent payment method may only be changed by agreement between the landlord and the tenant, and the landlord will not refuse if the tenant requests to change to an approved electronic bank transfer method or to Centrepay, and
 - 4.5 not to require the tenant to pay rent by a cheque or other negotiable instrument that is post-dated, and
 - 4.6 to accept payment of unpaid rent after the landlord has given a termination notice on the ground of failure to pay rent if the tenant has not vacated the residential premises, and
 - 4.7 not to use rent paid by the tenant for the purpose of any amount payable by the tenant other than rent, and
 - 4.8 if rent is paid by cheque – to make a rent receipt available for collection by the tenant, to post it to the residential premises or to send it by email to an email address specified in this agreement by the tenant for the service of documents of that kind, and
 - 4.9 if rent is not paid by cheque and is paid in person - to give a rent receipt to the tenant, and
 - 4.10 to keep a record of rent paid under this agreement and to provide a written statement showing the rent record for a specified period within 7 days of a request by the tenant, unless the landlord has previously provided a statement for the same period.

Note. The requirements relating to Centrepay do not apply to a residential tenancy agreement until a date notified in the Gazette by the Minister for Better Regulation and Fair Trading.

RENT INCREASES

5. **The landlord and the tenant agree** that the rent cannot be increased unless the landlord gives not less than 60 days written notice of the increase to the tenant. The notice must specify the increased rent and the day from which it is payable.
6. **The landlord and the tenant agree** that the rent may not be increased more than once in any period of 12 months.

Note: The period of 12 months includes the time during which a previous residential tenancy agreement was in force if:

 - (a) this agreement is a renewal or replacement of the previous agreement, and
 - (b) the landlord and at least one tenant are the same for both agreements, and
 - (c) under the previous agreement, the tenant occupied the residential premises immediately before the start of this agreement.
7. **The landlord and the tenant agree:**
 - 7.1 that the increased rent is payable from the day specified in the notice, and
 - 7.2 that the landlord may cancel or reduce the rent increase by a later notice that takes effect on the same day as the original notice, and
 - 7.3 that increased rent under this agreement is not payable unless the rent is increased in accordance with this agreement and the *Residential Tenancies Act 2010* or by the Civil and Administrative Tribunal.

RENT REDUCTIONS

8. **The landlord and the tenant agree** that the rent abates if the residential premises:
 - 8.1 are destroyed, or become wholly or partly uninhabitable, otherwise than as a result of a breach of this agreement, or
 - 8.2 cease to be lawfully usable as a residence, or
 - 8.3 are compulsorily appropriated or acquired by an authority.
9. The landlord and the tenant may, at any time during this agreement, agree to reduce the rent payable.

PAYMENT OF COUNCIL RATES, LAND TAX, WATER AND OTHER CHARGES

10. **The landlord agrees** to pay:
 - 10.1 rates, taxes or charges payable under any Act (other than charges payable by the tenant under this agreement), and
 - 10.2 the installation costs and charges for initial connection to the residential premises of an electricity, water, gas, bottled gas or oil supply service, and
 - 10.3 all charges for the supply of electricity, non-bottled gas or oil to the tenant at the residential premises that are not separately metered, and

Note 1. Clause 10.3 does not apply to premises located in an embedded network in certain circumstances in accordance with clauses 34 and 35 of the *Residential Tenancies Regulation 2019*.

Note 2. Clause 10.3 does not apply to social housing tenancy agreements in certain circumstances, in accordance with clause 36 of the *Residential Tenancies Regulation 2019*.

 - 10.4 the costs and charges for the supply or hire of gas bottles for the supply of bottled gas at the commencement of the tenancy, and
 - 10.5 all charges (other than water usage charges) in connection with a water supply service to separately metered residential premises, and

RESIDENTIAL TENANCY AGREEMENT

- 10.6** all charges in connection with a water supply service to residential premises that are not separately metered, and
- 10.7** all charges for the supply of sewerage services (other than for pump out septic services) or the supply or use of drainage services to the residential premises, and
- 10.8** all service availability charges, however described, for the supply of non-bottled gas to the residential premises if the premises are separately metered but do not have any appliances, supplied by the landlord, for which gas is required and the tenant does not use gas supplied to the premises, and
- 10.9** the costs and charges for repair, maintenance or other work carried out on the residential premises which is required to facilitate the proper installation or replacement of an electricity meter, in working order, including an advanced meter, if the meter installation is required by the retailer to replace an existing meter because the meter is faulty, testing indicates the meter may become faulty or the meter has reached the end of its life.
- 11. The tenant agrees to pay:**
- 11.1** all charges for the supply of electricity or oil to the tenant at the residential premises if the premises are separately metered, and
- 11.2** all charges for the supply of non-bottled gas to the tenant at the residential premises if the premises are separately metered, unless the premises do not have any appliances supplied by the landlord for which gas is required and the tenant does not use gas supplied to the premises, and
- Note.** Charges for the supply of gas in certain circumstances may also be payable by a tenant under a social housing agreement in accordance with clause 36 of the *Residential Tenancies Regulation 2019*.
- 11.3** all charges for the supply of bottled gas to the tenant at the residential premises except for the costs and charges for the supply or hire of gas bottles at the start of the tenancy, and
- 11.4** all charges for pumping out a septic system used for the residential premises, and
- 11.5** any excess garbage charges relating to the tenant's use of the residential premises, and
- 11.6** water usage charges, if the landlord has installed water efficiency measures referred to in clause 10 of the *Residential Tenancies Regulation 2019* and the residential premises:
- 11.6.1** are separately metered, or
- 11.6.2** are not connected to a water supply service and water is delivered by vehicle.
- Note.** *Separately metered* is defined in the *Residential Tenancies Act 2010*.
- 12. The landlord agrees that the tenant is not required to pay water usage charges unless:**
- 12.1** the landlord gives the tenant a copy of the part of the water supply authority's bill setting out the charges, or other evidence of the cost of water used by the tenant, and
- 12.2** the landlord gives the tenant at least 21 days to pay the charges, and
- 12.3** the landlord requests payment of the charges by the tenant not later than 3 months after the issue of the bill for the charges by the water supply authority, and
- 12.4** the residential premises have the following water efficiency measures:
- 12.4.1** all internal cold water taps and single mixer taps for kitchen sinks or bathroom hand basins on the premises have a maximum flow rate of 9 litres a minute,
- 12.4.2** all toilets are dual flush toilets that have a minimum 3 star rating in accordance with the WELS scheme,
- 12.4.3** all showerheads have a maximum flow rate of 9 litres a minute,
- 12.4.4** at the commencement of the residential tenancy agreement and whenever any other water efficiency measures are installed, repaired or upgraded, the premises are checked and any leaking taps or toilets on the premises have been fixed.
- 13. The landlord agrees to give the tenant the benefit of, or an amount equivalent to, any rebate received by the landlord for water usage charges payable or paid by the tenant.**
- POSSESSION OF THE PREMISES**
- 14. The landlord agrees:**
- 14.1** to make sure the residential premises are vacant so the tenant can move in on the date agreed, and
- 14.2** to take all reasonable steps to ensure that, at the time of signing this agreement, there is no legal reason why the premises cannot be used as a residence for the term of this agreement.
- TENANT'S RIGHT TO QUIET ENJOYMENT**
- 15. The landlord agrees:**
- 15.1** that the tenant will have quiet enjoyment of the residential premises without interruption by the landlord or any person claiming by, through or under the landlord or having superior title to that of the landlord (such as a head landlord), and
- 15.2** that the landlord or the landlord's agent will not interfere with, or cause or permit any interference with, the reasonable peace, comfort or privacy of the tenant in using the residential premises, and
- 15.3** that the landlord or the landlord's agent will take all reasonable steps to ensure that the landlord's other neighbouring tenants do not interfere with the reasonable peace, comfort or privacy of the tenant in using the residential premises.
- USE OF THE PREMISES BY TENANT**
- 16. The tenant agrees:**
- 16.1** not to use the residential premises, or cause or permit the premises to be used, for any illegal purpose, and
- 16.2** not to cause or permit a nuisance, and
- 16.3** not to interfere, or cause or permit interference, with the reasonable peace, comfort or privacy of neighbours, and
- 16.4** not to intentionally or negligently cause or permit any damage to the residential premises, and
- 16.5** not to cause or permit more people to reside in the residential premises than is permitted by this agreement.
- 17. The tenant agrees:**
- 17.1** to keep the residential premises reasonably clean, and
- 17.2** to notify the landlord as soon as practicable of any damage to the residential premises, and
- 17.3** that the tenant is responsible to the landlord for any act or omission by a person who is lawfully on the residential premises if the person is only permitted on the premises with the tenant's consent and the act or omission would be in breach of this agreement if done or omitted by the tenant, and
- 17.4** that it is the tenant's responsibility to replace light globes on the residential premises.

RESIDENTIAL TENANCY AGREEMENT

- 18. The tenant agrees**, when this agreement ends and before giving vacant possession of the premises to the landlord:
- 18.1** to remove all the tenant's goods from the residential premises, and
 - 18.2** to leave the residential premises as nearly as possible in the same condition, fair wear and tear excepted, as at the commencement of the tenancy, and
 - 18.3** to leave the residential premises reasonably clean, having regard to their condition at the commencement of the tenancy, and
 - 18.4** to remove or arrange for the removal of all rubbish from the residential premises in a way that is lawful and in accordance with council requirements, and
 - 18.5** to make sure that all light fittings on the premises have working globes, and
 - 18.6** to return to the landlord all keys, and other opening devices or similar devices, provided by the landlord.

Note. Under section 54 of the *Residential Tenancies Act 2010*, the vicarious liability of a tenant for damage to residential premises caused by another person is not imposed on a tenant who is the victim of a domestic violence offence, or a co-tenant who is not a relevant domestic violence offender, if the damage occurred during the commission of a domestic violence offence (within the meaning of that Act).

LANDLORD'S GENERAL OBLIGATIONS FOR RESIDENTIAL PREMISES

19. The landlord agrees:

- 19.1** to make sure that the residential premises are reasonably clean and fit to live in, and
- Note 1.** Section 52 of the *Residential Tenancies Act 2010* specifies the minimum requirements that must be met for residential premises to be fit to live in. These include that the residential premises:
- (a) are structurally sound, and
 - (b) have adequate natural light or artificial lighting in each room of the premises other than a room that is intended to be used only for the purposes of storage or a garage, and
 - (c) have adequate ventilation, and
 - (d) are supplied with electricity or gas and have an adequate number of electricity outlet sockets or gas outlet sockets for the supply of lighting and heating to, and use of appliances in, the premises, and
 - (e) have adequate plumbing and drainage, and
 - (f) are connected to a water supply service or infrastructure that supplies water (including, but not limited to, a water bore or water tank) that is able to supply to the premises hot and cold water for drinking and ablution and cleaning activities, and
 - (g) contain bathroom facilities, including toilet and washing facilities, that allow privacy for the user.
- Note 2.** Premises are structurally sound only if the floors, ceilings, walls, supporting structures (including foundations), doors, windows, roof, stairs, balconies, balustrades and railings:
- (a) are in a reasonable state of repair, and
 - (b) with respect to the floors, ceilings, walls and supporting structures—are not subject to significant dampness, and
 - (c) with respect to the roof, ceilings and windows—do not allow water penetration into the premises, and
 - (d) are not liable to collapse because they are rotted or otherwise defective.
- 19.2** to make sure that all light fittings on the residential premises have working light globes on the commencement of the tenancy, and

- 19.3** to keep the residential premises in a reasonable state of repair, considering the age of, the rent paid for and the prospective life of the premises, and
- 19.4** not to interfere with the supply of gas, electricity, water, telecommunications or other services to the residential premises (unless the interference is necessary to avoid danger to any person or enable maintenance or repairs to be carried out), and
- 19.5** not to hinder a tradesperson's entry to the residential premises when the tradesperson is carrying out maintenance or repairs necessary to avoid health or safety risks to any person, or to avoid a risk that the supply of gas, electricity, water, telecommunications or other services to the residential premises may be disconnected, and
- 19.6** to comply with all statutory obligations relating to the health or safety of the residential premises, and
- 19.7** that a tenant who is the victim of a domestic violence offence or a co-tenant who is under the same agreement as the victim of the domestic violence offence but is not a relevant domestic violence offender is not responsible to the landlord for any act or omission by a co-tenant that is a breach of this agreement if the act or omission constitutes or resulted in damage to the premises and occurred during the commission of a domestic violence offence.

URGENT REPAIRS

- 20. The landlord agrees** to pay the tenant, within 14 days after receiving written notice from the tenant, any reasonable costs (not exceeding \$1,000) that the tenant has incurred for making urgent repairs to the residential premises (of the type set out below) so long as:
- 20.1** the damage was not caused as a result of a breach of this agreement by the tenant, and
 - 20.2** the tenant gives or makes a reasonable attempt to give the landlord notice of the damage, and
 - 20.3** the tenant gives the landlord a reasonable opportunity to make the repairs, and
 - 20.4** the tenant makes a reasonable attempt to have any appropriate tradesperson named in this agreement make the repairs, and
 - 20.5** the repairs are carried out, where appropriate, by licensed or properly qualified persons, and
 - 20.6** the tenant, as soon as possible, gives or tries to give the landlord written details of the repairs, including the cost and the receipts for anything the tenant pays for.
- Note.** The type of repairs that are **urgent repairs** are defined in the *Residential Tenancies Act 2010* and are defined as follows:
- (a) a burst water service,
 - (b) an appliance, fitting or fixture that uses water or is used to supply water that is broken or not functioning properly, so that a substantial amount of water is being wasted,
 - (c) a blocked or broken lavatory system,
 - (d) a serious roof leak,
 - (e) a gas leak,
 - (f) a dangerous electrical fault,
 - (g) flooding or serious flood damage,
 - (h) serious storm or fire damage,
 - (i) a failure or breakdown of the gas, electricity or water supply to the premises,
 - (j) a failure or breakdown of any essential service on the residential premises for hot water, cooking, heating, cooling or laundering,
 - (k) any fault or damage that causes the premises to be unsafe or insecure.

SALE OF THE PREMISES

21. The landlord agrees:

- 21.1 to give the tenant written notice that the landlord intends to sell the residential premises, at least 14 days before the premises are made available for inspection by potential purchasers, and
- 21.2 to make all reasonable efforts to agree with the tenant as to the days and times when the residential premises are to be available for inspection by potential purchasers.

22. The tenant agrees not to unreasonably refuse to agree to days and times when the residential premises are to be available for inspection by potential purchasers.

23. The landlord and the tenant agree:

- 23.1 that the tenant is not required to agree to the residential premises being available for inspection more than twice in a period of a week, and
- 23.2 that, if they fail to agree, the landlord may show the residential premises to potential purchasers not more than twice in any period of a week and must give the tenant at least 48 hours notice each time.

LANDLORD'S ACCESS TO THE PREMISES

24. The landlord agrees that the landlord, the landlord's agent or any person authorised in writing by the landlord, during the currency of this agreement, may only enter the residential premises in the following circumstances:

- 24.1 in an emergency (including entry for the purpose of carrying out urgent repairs),
- 24.2 if the Civil and Administrative Tribunal so orders,
- 24.3 if there is good reason for the landlord to believe the premises are abandoned,
- 24.4 if there is good reason for serious concern about the health of the tenant or any other person on the residential premises and a reasonable attempt has been made to obtain consent to the entry,
- 24.5 to inspect the premises, if the tenant is given at least 7 days written notice (no more than 4 inspections are allowed in any period of 12 months),
- 24.6 to carry out, or assess the need for, necessary repairs, if the tenant is given at least 2 days notice each time,
- 24.7 to carry out, or assess the need for, work relating to statutory health and safety obligations relating to the residential premises, if the tenant is given at least 2 days notice each time,
- 24.8 to show the premises to prospective tenants on a reasonable number of occasions if the tenant is given reasonable notice on each occasion (this is only allowed during the last 14 days of the agreement),
- 24.9 to value the property, if the tenant is given 7 days notice (not more than one valuation is allowed in any period of 12 months),
- 24.10 to take photographs, or make visual recordings, of the inside of the premises in order to advertise the premises for sale or lease, if the tenant is given reasonable notice and reasonable opportunity to move any of their possessions that can reasonably be moved out of the frame of the photograph or the scope of the recording (this is only allowed once in a 28 day period before marketing of the premises starts for sale or lease or the termination of this agreement),
- 24.11 if the tenant agrees.

25. The landlord agrees that a person who enters the residential premises under clause 24.5, 24.6, 24.7, 24.8, 24.9 or 24.10 of this agreement:

- 25.1 must not enter the premises on a Sunday or a public holiday, unless the tenant agrees, and

25.2 may enter the premises only between the hours of 8.00 a.m. and 8.00 p.m., unless the tenant agrees to another time, and

25.3 must not stay on the residential premises longer than is necessary to achieve the purpose of the entry to the premises, and

25.4 must, if practicable, notify the tenant of the proposed day and time of entry.

26. The landlord agrees that, except in an emergency (including to carry out urgent repairs), a person other than the landlord or the landlord's agent must produce to the tenant the landlord's or the landlord's agent's written permission to enter the residential premises.

27. The tenant agrees to give access to the residential premises to the landlord, the landlord's agent or any person, if they are exercising a right to enter the residential premises in accordance with this agreement.

PUBLISHING PHOTOGRAPHS OR VISUAL RECORDINGS

28. The landlord agrees that the landlord or the landlord's agent must not publish any photographs taken or visual recordings made of the inside of the residential premises in which the tenant's possessions are visible unless they first obtain written consent from the tenant.

Note. See section 55A of the *Residential Tenancies Act 2010* for when a photograph or visual recording is published.

29. The tenant agrees not to unreasonably withhold consent. If the tenant is in circumstances of domestic violence within the meaning of section 105B of the *Residential Tenancies Act 2010*, it is not unreasonable for the tenant to withhold consent.

FIXTURES, ALTERATIONS, ADDITIONS OR RENOVATIONS TO THE PREMISES

30. The tenant agrees:

- 30.1 not to install any fixture or renovate, alter or add to the residential premises without the landlord's written permission, and
- 30.2 that certain kinds of fixtures or alterations, additions or renovations that are of a minor nature specified by clause 22(2) of the *Residential Tenancies Regulation 2019* may only be carried out by a person appropriately qualified to carry out those alterations unless the landlord gives consent, and
- 30.3 to pay the cost of a fixture, installed by or on behalf of the tenant, or any renovation, alteration or addition to the residential premises, unless the landlord otherwise agrees, and
- 30.4 not to remove, without the landlord's permission, any fixture attached by the tenant that was paid for by the landlord or for which the landlord gave the tenant a benefit equivalent to the cost of the fixture, and
- 30.5 to notify the landlord of any damage caused by removing any fixture attached by the tenant, and
- 30.6 to repair any damage caused by removing the fixture or compensate the landlord for the reasonable cost of repair.

31. The landlord agrees not to unreasonably withhold consent to a fixture, or to an alteration, addition or renovation that is of a minor nature.

Note. The *Residential Tenancies Regulation 2019* provides a list of the kinds of fixtures or alterations, additions or renovations of a minor nature to which it would be unreasonable for a landlord to withhold consent and which of those fixtures, or alterations, additions or renovations the landlord may give consent to on the condition that the fixture or alteration, addition or renovation is carried out by an appropriately qualified person.

RESIDENTIAL TENANCY AGREEMENT

LOCKS AND SECURITY DEVICES

32. The landlord agrees:

- 32.1 to provide and maintain locks or other security devices necessary to keep the residential premises reasonably secure, and
- 32.2 to give each tenant under this agreement a copy of the key or opening device or information to open any lock or security device for the residential premises or common property to which the tenant is entitled to have access, and
- 32.3 not to charge the tenant for the cost of providing the copies except to recover the cost of replacement or additional copies, and
- 32.4 not to alter, remove or add any lock or other security device without reasonable excuse (which includes an emergency, an order of the Civil and Administrative Tribunal, termination of a co-tenancy or an apprehended violence order prohibiting a tenant or occupant from having access) or unless the tenant agrees, and
- 32.5 to give each tenant under this agreement a copy of any key or other opening device or information to open any lock or security device that the landlord changes as soon as practicable (and no later than 7 days) after the change.

33. The tenant agrees:

- 33.1 not to alter, remove or add any lock or other security device without reasonable excuse (which includes an emergency, an order of the Civil and Administrative Tribunal, termination of a co-tenancy or an apprehended violence order prohibiting a tenant or occupant from having access) or unless the landlord agrees, and
 - 33.2 to give the landlord a copy of the key or opening device or information to open any lock or security device that the tenant changes within 7 days of the change.
34. A copy of a changed key or other opening device need not be given to the other party if the other party agrees not to be given a copy or the Civil and Administrative Tribunal authorises a copy not to be given or the other party is prohibited from access to the residential premises by an apprehended violence order.

TRANSFER OF TENANCY OR SUB-LETTING BY TENANT

35. The landlord and the tenant agree that:

- 35.1 the tenant may, with the landlord's written permission, transfer the tenant's tenancy under this agreement or sub-let the residential premises, and
- 35.2 the landlord may refuse permission (whether or not it is reasonable to do so) to the transfer of the whole of the tenancy or sub-letting the whole of the residential premises, and
- 35.3 the landlord must not unreasonably refuse permission to a transfer of part of a tenancy or a sub-letting of part of the residential premises, and
- 35.4 without limiting clause 35.3, the landlord may refuse permission to a transfer of part of the tenancy or to sub-letting part of the residential premises if the number of occupants would be more than is permitted under this agreement or any proposed tenant or sub-tenant is listed on a residential tenancy database or it would result in overcrowding of the residential premises.

Note. Clauses 35.3 and 35.4 do not apply to social housing tenancy agreements.

36. The landlord agrees not to charge for giving permission other than for the landlords reasonable expenses in giving permission.

CHANGE IN DETAILS OF LANDLORD OR LANDLORD'S AGENT

37. The landlord agrees:

- 37.1 if the name and telephone number or contact details of the landlord change, to give the tenant notice in writing of the change within 14 days, and
- 37.2 if the address of the landlord changes (and the landlord does not have an agent), to give the tenant notice in writing of the change within 14 days, and
- 37.3 if the name, telephone number or business address of the landlord's agent changes or the landlord appoints an agent, to give the tenant notice in writing of the change or the agent's name, telephone number and business address, as appropriate, within 14 days, and
- 37.4 if the landlord or landlord's agent is a corporation and the name or business address of the corporation changes, to give the tenant notice in writing of the change within 14 days, and
- 37.5 if the State, Territory or country in which the landlord ordinarily resides changes, to give the tenant notice in writing of the change within 14 days.

COPY OF CERTAIN BY-LAWS TO BE PROVIDED

[Cross out if not applicable]

- 38. The landlord agrees to give to the tenant, before the tenant enters into this agreement, a copy of the by-laws applying to the residential premises if they are premises under the *Strata Schemes Management Act 2015*.
- 39. The landlord agrees to give to the tenant, within 7 days of entering into this agreement, a copy of the by-laws applying to the residential premises if they are premises under the *Strata Schemes Development Act 2015*, the *Community Land Development Act 1989* or the *Community Land Management Act 1989*.

MITIGATION OF LOSS

- 40. The rules of law relating to mitigation of loss or damage on breach of a contract apply to a breach of this agreement. (For example, if the tenant breaches this agreement, the landlord will not be able to claim damages for loss which could have been avoided by reasonable effort by the landlord.)

RENTAL BOND

[Cross out this clause if no rental bond is payable]

- 41. The landlord agrees that, where the landlord or the landlord's agent applies to the Rental Bond Board or the Civil and Administrative Tribunal for payment of the whole or part of the rental bond to the landlord, the landlord or the landlord's agent will provide the tenant with:
 - 41.1 details of the amount claimed, and
 - 41.2 copies of any quotations, accounts and receipts that are relevant to the claim, and
 - 41.3 a copy of a completed condition report about the residential premises at the end of the residential tenancy agreement.

SMOKE ALARMS

42. The landlord agrees to:

- 42.1 ensure that smoke alarms are installed in accordance with the *Environmental Planning and Assessment Act 1979* if that Act requires them to be installed in the premises and are functioning in accordance with the regulations under that Act, and
- 42.2 conduct an annual check of all smoke alarms installed on the residential premises to ensure that the smoke alarms are functioning, and
- 42.3 install or replace, or engage a person to install or replace, all removable batteries in all smoke alarms installed on the residential premises annually, except for smoke alarms that have a removable lithium battery, and

RESIDENTIAL TENANCY AGREEMENT

- 42.4 install or replace, or engage a person to install or replace, a removable lithium battery in a smoke alarm in the period specified by the manufacturer of the smoke alarm, and
- 42.5 engage an authorised electrician to repair or replace a hardwired smoke alarm, and
- 42.6 repair or replace a smoke alarm within 2 business days of becoming aware that the smoke alarm is not working unless the tenant notifies the landlord that the tenant will carry out the repair to the smoke alarm and the tenant carries out the repair, and
- 42.7 reimburse the tenant for the costs of a repair or replacement of a smoke alarm in accordance with clause 18 of the *Residential Tenancies Regulation 2019*, that the tenant is allowed to carry out.

Note 1. Under section 64A of the *Residential Tenancies Act 2010*, repairs to a smoke alarm includes maintenance of a smoke alarm in working order by installing or replacing a battery in the smoke alarm.

Note 2. Clauses 42.2–42.7 do not apply to a landlord of premises that comprise or include a lot in a strata scheme (within the meaning of the *Strata Schemes Management Act 2015*) if the owners corporation is responsible for the repair and replacement of smoke alarms in the residential premises.

Note 3. A tenant who intends to carry out a repair to a smoke alarm may do so only in the circumstances prescribed for a tenant in clause 15 of the *Residential Tenancies Regulation 2019*.

Note 4. Section 64A of the Act provides that a smoke alarm includes a heat alarm.

43. The tenant agrees:

- 43.1 to notify the landlord if a repair or a replacement of a smoke alarm is required, including replacing a battery in the smoke alarm, and
- 43.2 that the tenant may only replace a battery in a battery-operated smoke alarm, or a back-up battery in a hardwired smoke alarm, if the smoke alarm has a removable battery or a removable back-up battery, and
- 43.3 to give the landlord written notice, as soon as practicable if the tenant will carry out and has carried out a repair or replacement, or engages a person to carry out a repair or replacement, in accordance with clauses 15–17 of the *Residential Tenancies Regulation 2019*.

Note. Clauses 43.2 and 43.3 do not apply to tenants under social housing tenancy agreements or tenants of premises that comprise or include a lot in a strata scheme (within the meaning of the *Strata Schemes Management Act 2015*) if the owners corporation is responsible for the repair and replacement of smoke alarms in the residential premises.

44. **The landlord and the tenant each agree** not to remove or interfere with the operation of a smoke alarm installed on the residential premises unless they have a reasonable excuse to do so.

Note. The regulations made under the *Environmental Planning and Assessment Act 1979* provide that it is an offence to remove or interfere with the operation of a smoke alarm or a heat alarm in particular circumstances.

SWIMMING POOLS

[Cross out this clause if there is no swimming pool]

~~46. The landlord agrees to ensure that the requirements of the *Swimming Pools Act 1992* have been complied with in respect of the swimming pool on the residential premises.~~

[Cross out the following clause if there is no swimming pool or the swimming pool is situated on land in a strata scheme (within the meaning of the *Strata Schemes Management Act 2015*) or in a community scheme (within the meaning of the *Community Land Development Act 1989*) and that strata or community scheme comprises more than 2 lots]

~~46. The landlord agrees to ensure that at the time that this residential tenancy agreement is entered into:~~

~~46.1 the swimming pool on the residential premises is registered under the *Swimming Pools Act 1992* and has a valid certificate of compliance under that Act or a relevant occupation certificate within the meaning of that Act, and~~

~~46.2 a copy of that valid certificate of compliance or relevant occupation certificate is provided to the tenant.~~

Note. A swimming pool certificate of compliance is valid for 3 years from its date of issue.

LOOSE-FILL ASBESTOS INSULATION

47. The landlord agrees:

- 47.1 if, at the time that this residential tenancy agreement is entered into, the premises have been and remain listed on the LFAI Register, the tenant has been advised in writing by the landlord that the premises are listed on that Register, or
- 47.2 if, during the tenancy, the premises become listed on the LFAI Register, to advise the tenant in writing, within 14 days of the premises being listed on the Register, that the premises are listed on the Register.

COMBUSTIBLE CLADDING

48. **The landlord agrees** that if, during the tenancy, the landlord becomes aware of any of the following facts, the landlord will advise the tenant in writing within 14 days of becoming aware of the fact:

- 48.1 that the residential premises are part of a building in relation to which a notice of intention to issue a fire safety order, or a fire safety order, has been issued requiring rectification of the building regarding external combustible cladding,
- 48.2 that the residential premises are part of a building in relation to which a notice of intention to issue a building product rectification order, or a building product rectification order, has been issued requiring rectification of the building regarding external combustible cladding,
- 48.3 that the residential premises are part of a building where a development application or complying development certificate application has been lodged for rectification of the building regarding external combustible cladding.

SIGNIFICANT HEALTH OR SAFETY RISKS

49. **The landlord agrees** that if, during the tenancy, the landlord becomes aware that the premises are subject to a significant health or safety risk, the landlord will advise the tenant in writing, within 14 days of becoming aware, that the premises are subject to the significant health or safety risk and the nature of the risk.

ELECTRONIC SERVICE OF NOTICES AND OTHER DOCUMENTS

50. The landlord and the tenant agree:

- 50.1 to only serve any notices and any other documents, authorised or required by the *Residential Tenancies Act 2010* or the regulations or this agreement, on the other party by email if the other party has provided express consent, either as part of this agreement or otherwise, that a specified email address is to be used for the purpose of serving notices and other documents, and
- 50.2 to notify the other party in writing within 7 days if the email address specified for electronic service of notices and other documents changes, and
- 50.3 that they may withdraw their consent to the electronic service of notices and other documents at any time, by notifying the other party in writing, and
- 50.4 if a notice is given withdrawing consent to electronic service of notices and other documents, following the giving of such notice, no further notices or other documents are to be served by email.

BREAK FEE FOR FIXED TERM OF NOT MORE THAN 3 YEARS

51. The tenant agrees that, if the tenant ends the residential tenancy agreement before the end of the fixed term of the agreement, the tenant must pay a break fee of the following amount if the fixed term is not more than 3 years:

- 51.1** 4 weeks rent if less than 25% of the fixed term has expired,
- 51.2** 3 weeks rent if 25% or more but less than 50% of the fixed term has expired,
- 51.3** 2 weeks rent if 50% or more but less than 75% of the fixed term has expired,
- 51.4** 1 week's rent if 75% or more of the fixed term has expired.

This clause does not apply if the tenant terminates a fixed term residential tenancy agreement for a fixed term of more than 3 years or if the tenant terminates a residential tenancy agreement early for a reason that is permitted under the *Residential Tenancies Act 2010*.

Note. Permitted reasons for early termination include destruction of residential premises, breach of the agreement by the landlord and an offer of social housing or a place in an aged care facility, and being in circumstances of domestic violence. Section 107 of the *Residential Tenancies Act 2010* regulates the rights of the landlord and tenant under this clause.

52. The landlord agrees that the compensation payable by the tenant for ending the residential tenancy agreement before the end of the fixed term of not more than 3 years is limited to the amount specified in clause 51 and any occupation fee payable under the *Residential Tenancies Act 2010* for goods left on the residential premises.

Note. Section 107 of the *Residential Tenancies Act 2010* also regulates the rights of landlords and tenants for a residential tenancy agreement with a fixed term of more than 3 years.

LANDLORD'S CONSENT FOR PETS

53. The landlord and the tenant agree:

53.1 the tenant may keep and animal at the residential premises with the landlord's consent, and

Note: The tenant does not need the landlord's consent to keep an assistance animal at the residential premises.

53.2 an application for consent to keep an animal at the premises must be made jointly by all co-tenants using the Fair Trading approved form and the landlord must respond in writing to the application using that form, and

53.3 the landlord may give consent to keep an animal at the premises subject to reasonable conditions, which are taken to be the terms of this agreement.

54. The landlord agrees:

54.1 to respond to an application from the tenant for consent to keep an animal at the residential premises within 21 days, specifying either that consent is given and any reasonable conditions of the consent or that consent is refused and the grounds for refusing, and

54.2 if the landlord does not give a response under clause 54.1 to an application for consent to keep an animal, the landlord consents to the tenant keeping the animal at the premises without conditions, and

54.3 to not refuse to consent to an animal being kept at the premises except on a ground set out in the *Residential Tenancies Act 2010*, section 73F, and

54.4 to not impose an unreasonable condition on a consent to keep an animal at the premises, and

Note: The *Residential Tenancies Act 2010*, section 73E sets out what are reasonable and unreasonable conditions of a consent to keep an animal at the residential premises.

54.5 if the landlord consents to the tenant keeping an animal at the premises, the consent continues while the tenant resides at the premises for the lifetime of the animal.

TERMINATION

55. The landlord and the tenant agree to only end this agreement in accordance with the *Residential Tenancies Act 2010* and the *Residential Tenancies Regulation 2019*.

ADDITIONAL TERMS

[Additional terms may be included in this agreement if:

- (a) both the landlord and the tenant agree to the terms, and
- (b) they do not conflict with the *Residential Tenancies Act 2010*, the *Residential Tenancies Regulation 2019* or any other Act, and
- (c) they do not conflict with the standard terms of this agreement.

ANY ADDITIONAL TERMS ARE NOT REQUIRED BY LAW AND ARE NEGOTIABLE.]

ADDITIONAL TERMS - PETS

[Cross out these clauses if not applicable: Clauses 57-60 must only be included in this agreement if the clauses are reasonable conditions for keeping the animal at the residential premises.]

56. The landlord agrees the tenant may keep the following animal at the residential premises [insert description of animal].

One dog

57. [If the animal will be kept inside at the premises, and this clause is reasonable for the type of animal and the premises]

The tenant agrees to have the carpets professionally cleaned, or to pay the cost of having the carpet professionally cleaned, at the end of the tenancy if cleaning is required because the animal has been kept inside at the premises during the tenancy.

58. [If the animal is a mammal and will be kept inside the premises]

The tenant agrees to have the premises professionally fumigated, or to pay the cost of having the premises professionally fumigated, at the end of the tenancy if required because the animal has been kept inside at the premises during the tenancy.

59. [If the animal is a type of animal that is not normally kept inside]

The tenant agrees to take reasonable steps to prevent the animal inside at the premises.

60. The tenant agrees

60.1 to supervise the animal and keep the animal within the boundaries of the premises, and

60.2 to ensure that the animal does not cause a nuisance, or breach the reasonable peace, comfort or privacy of neighbours, and

60.3 to ensure that the animal is registered and micro-chipped if required under law, and

60.4 to comply with any council requirements, and

60.5 not to inter the remains of any animals on any part of the residential premises.

Note: Clauses 60.1 to 60.5 must only be included in this agreement if the clauses are reasonable conditions for keeping the animal at the residential premises. You should carefully consider whether they are reasonable in the circumstances as an unreasonable condition is void and has no effect in accordance with the *Residential Tenancies Act 2010* (NSW).

61. The tenant must not keep an animal at the premises unless:

61.1 the tenant has obtained the landlord's consent, whether under this agreement or under the *Residential Tenancies Act 2010* (NSW) to keep the animal at the premises; or

61.2 the *Residential Tenancies Act 2010* (NSW) or a term of this agreement permits the tenant to keep that animal at the premises without any requirement to obtain the landlord's consent.

ADDITIONAL TERM - MATERIAL FACTS

[Cross out this clause if not applicable]

~~62. The landlord advises the tenant of the existence of the following material fact(s) (as prescribed by the Residential Tenancies Regulation 2010 (NSW)) in relation to the premises:~~

ADDITIONAL TERM - AGREEMENT TO USE PREVIOUS CONDITION REPORT

63. The landlord and tenant:

- 63.1 agree that the condition report included in a residential tenancy agreement entered into by the tenant and dated 10 / 05 / 2023 (insert a date if the landlord and tenant agree to this clause) forms part of this agreement;
- 63.2 acknowledge that the tenant's responses in that condition report form part of this agreement, and
- 63.3 agree that two physical copies of that condition report, or one electronic copy, have been given to the tenant on or before the date of this agreement.

ADDITIONAL TERM - TENANT'S CARE AND USE OF THE RESIDENTIAL PREMISES

64. Further to clauses 16 and 17 and subject to any applicable by-law, the tenant agrees:

- 64.1 to use the residential premises for residential purposes only;
- 64.2 not to use the premises for the purpose of a trade, profession or business;
- 64.3 not to use, advertise for use, sub-let, licence, transfer or otherwise part with possession of the whole or any part of the residential premises for the purpose of giving a person the right to occupy the residential premises for the purpose of a holiday, without the prior written consent of the landlord where such consent may be refused in the landlord's absolute discretion;
- 64.4 to clean the residential premises regularly with special attention to the kitchen, bathroom and appliances;
- 64.5 to put nothing down any sink, toilet or drain likely to cause obstruction or damage;
- 64.6 to wrap up and place garbage in a suitable container;
- 64.7 to regularly mow the lawns and keep the grounds and garden tidy and free of weeds and rubbish and maintain them in their condition, fair wear and tear excepted, as at the commencement of this agreement;
- 64.8 to take special care of the items let with the residential premises including any furniture, furnishings and appliances;
- 64.9 to do no decorating that involves painting, marking or defacing the residential premises or fixing posters without the prior written consent of the landlord or an order of the Civil and Administrative Tribunal;
- 64.10 to ensure that nothing is done that may prejudice any insurance policy or increase the premium payable under any insurance policy held by the landlord in relation to the residential premises and to ensure that nothing is done on the residential premises which may expose the owner to any claims or liability or which might give rise to an insurance claim;

- 64.11 to notify the landlord promptly of any infectious disease or the presence of rats, cockroaches, fleas or other pests;
- 64.12 to ventilate, in an adequate and timely manner and, if applicable, without any alteration or addition to the common property, all rooms and areas in the residential premises and to prevent the growth of mould;
- 64.13 not to remove, alter or damage any water efficiency measure installed in the residential premises;
- 64.14 not to store rubbish, unregistered vehicles, any inflammable, dangerous or hazardous chemical, liquid or gas (with the exception of petrol or gas stored in the fuel tank of any registered motor vehicle) or other inflammable, dangerous or hazardous material on the residential premises, and storage of any items on the residential premises is at the tenant's own risk; and
- 64.15 to take out and bring in, in accordance with the scheduled garbage collection days, and to keep clean, all bins that are supplied with the residential premises and to pay the cost of repair or replacement of any bins that become damaged, lost or stolen (if not repaired or replaced at the cost of the relevant authority) whilst the tenant is in occupation of the residential premises.

ADDITIONAL TERM - TELECOMMUNICATIONS SERVICES

65. The tenant agrees:

- 65.1 to leave, in the same manner of connection or operation, any telephone service installed in the residential premises at the commencement of this agreement; and
- 65.2 the availability of telephone or fax lines, internet services, analogue, digital or cable television (and the adequacy of such services) are the sole responsibility of the tenant and the tenant should make their own enquiries as to the availability and adequacy of such services before executing this agreement. The landlord does not warrant that any telephone or fax plugs, antenna sockets or other such sockets or service points located in the residential premises are serviceable, or will otherwise meet the requirements of the tenant, and tenants must rely upon their own enquiries. The landlord is not obliged to install any antenna, plugs or sockets including but not limited to any digital aeriels or antennas or to carry out any upgrades in respect of television or internet reception on the residential premises.

ADDITIONAL TERM - RENT AND RENTAL BOND

66. The tenant agrees:

- 66.1 to pay the rent on or before the day which the term of this agreement begins; and
 - 66.2 not to apply any rental bond towards payment of the rent without the prior written consent of the landlord.
67. The landlord and the tenant may, by agreement, change the manner in which rent is payable under this agreement.

ADDITIONAL TERM - OCCUPANTS

68. The tenant agrees:

- 68.1 not to part with possession other than in accordance with the provisions of this agreement or the Residential Tenancies Act 2010, and
- 68.2 to ensure that occupants and other persons who come on to the residential premises with the tenant's consent comply with the conditions of this agreement.

ADDITIONAL TERM - TERMINATION

- 69. The tenant acknowledges that a notice of termination does not by itself end the tenant's obligations under this agreement.



RESIDENTIAL TENANCY AGREEMENT



70. The tenant agrees:

- 70.1 upon termination of this agreement, to:
 - (a) promptly and peacefully deliver up vacant possession of the residential premises to the landlord by the date specified in the termination notice or otherwise in accordance with the *Residential Tenancies Act 2010*;
 - (b) promptly notify the landlord or the landlord's agent of the tenant's forwarding address; and
 - (c) comply with its obligations in clause 18 of this agreement; and

70.2 that the tenant's obligations under this agreement continue until such time as the tenant has provided vacant possession of the residential premises, left them in the condition required under this agreement and returned to the landlord or the landlord's agent all keys, access cards, locks and other opening devices and security items.

71. Notwithstanding any termination of this agreement, the tenant acknowledges and agrees that an application may be made to the Civil and Administrative Tribunal if the tenant does not vacate when required or otherwise does not comply with this agreement.

72. The landlord and the tenant agree that:

- 72.1 any action by the landlord or the tenant to terminate this agreement shall not affect any claim for compensation in respect of a breach of this agreement; and
- 72.1 the acceptance of or demand for rent or other money by the landlord after service of a termination notice for breach does not operate as a waiver of that notice nor does it evidence the creation of a new tenancy.

Note: This agreement may only be terminated by the landlord on certain grounds set out in the *Residential Tenancies Act 2010* (NSW). Examples of where this agreement can be ended include where a party has breached the agreement (in which case the notice period is not less than 14 days) where the rent has remained unpaid in breach of the agreement for not less than 14 days, or where this is a periodic agreement and the landlord has entered into a contract for the sale of the premises which requires vacant possession (in which case the notice period is not less than 30 days). These are examples only and there are other grounds on which the landlord may terminate this agreement.

Note: If the tenant breaches this agreement the landlord should refer to section 87C of the *Residential Tenancies Act 2010*.

ADDITIONAL TERM - STATUTES, STRATA BY-LAWS, RULES AND SPECIAL CONDITIONS FOR FLATS

73. The tenant acknowledges and agrees:

- 73.1 to observe all relevant statutes, statutory regulations, strata by-laws, company title rules and community title rules relating to health, safety, noise and other housing standards with respect to the residential premises;
- 73.2 where the residential premises are subject to the *Strata Schemes Management Act 2015*, the *Strata Schemes Development Act 2015*, the *Community Land Development Act 1989* or the *Community Land Management Act 1989*, to observe and comply with any applicable strata by-laws and/or management statements and any applicable law;
- 73.3 where the residential premises are a flat (not subject to the *Strata Schemes Management Act 2015*, the *Strata Schemes Development Act 2015*, the *Community Land Development Act 1989* or the *Community Land Management Act 1989*), to comply with any applicable law and the special conditions contained in Schedule A of this agreement and any other special conditions as notified to the tenant from time to time; and
- 73.4 that, at the tenant's cost, the owners corporation or strata managing agent may dispose of abandoned goods, perishable goods or rubbish left on common property.

ADDITIONAL TERM - SWIMMING POOLS

(This clause does not apply when there is no pool on the residential premises)

~~74. Unless otherwise agreed by the landlord and tenant in writing, the tenant agrees:~~

- ~~74.1 to vacuum, brush and clean the pool, backwash the filter and empty the leaf basket(s) regularly, keeping them free from leaf litter and other debris;~~
- ~~74.2 to have the pool water tested once a month at a pool shop and to purchase and use the appropriate chemicals to keep the water clean and clear;~~
- ~~74.3 to keep the water level above the filter inlet at all times;~~
- ~~74.4 to notify the landlord or the landlord's agent as soon as practicable of any problems with the pool, equipment, safety gate, access door, fence or barrier;~~
- ~~74.5 not to interfere with the operation of any pool safety gate, access door, fence or barrier including not propping or holding open any safety gate or access door, nor leaving any item or object near a pool safety gate, access door, fence or barrier which would aid or allow access by children to the pool area or allow children to climb the pool safety gate, access door, fence or barrier; and~~
- ~~74.6 to ensure that the pool safety gate or access door is self-closing at all times.~~

ADDITIONAL TERM - RENT INCREASES

~~75. By completing this clause, the parties agree that the rent will be increased during the fixed term of the agreement as follows:~~

- ~~75.1 the rent will be increased to~~
~~_____ per~~
~~_____ on _____ / _____ / _____ and~~
~~to _____ per~~
~~_____ on _____ / _____ / _____ per~~

~~75.2 the rent increase can be calculated by the following method (set out details below):~~

~~Note: The rent payable under a residential tenancy agreement may be increased only if: (a) the tenant is given a written notice by the landlord or the landlord's agent specifying the increased rent and the day from which it is payable; and (b) the notice is given at least 60 days before the increased rent is payable. These requirements apply even if details of the rent increase are set out in the residential tenancy agreement. Please refer to section 41 of the Residential Tenancies Act 2010 (NSW).~~

ADDITIONAL TERM - CONDITION REPORT FORMS PART OF THIS AGREEMENT

76. For avoidance of doubt:

- 76.1 a condition report which accompanies this agreement, forms part of this agreement; and
- 76.2 a condition report that is signed by both the landlord and the tenant is presumed to be a correct statement, in the absence of evidence to the contrary, of the state of repair or general condition of the residential premises on the day specified in the report.

77. Clause 76.2 does not apply:

- 77.1 to any matter that could not have reasonably been discovered on a reasonable inspection of the residential premises; or
- 77.2 to any statement in the condition report about which the tenant makes a written dissenting comment on the copy of the report completed by the tenant and retained by the landlord.

ADDITIONAL TERM – ADDITIONAL TENANTS AND ADDITIONAL LANDLORDS

78. If an Additional Tenant Annexure is attached to this agreement:

- 78.1 that document forms part of this agreement; and
- 78.2 the tenant under this agreement includes each person named in that document as a tenant.

79. If an Additional Landlord Annexure is attached to this agreement:

- 79.1 that document forms part of this agreement; and
- 79.2 the landlord under this agreement includes each person named in that document as a landlord.

ADDITIONAL TERM – ADDITIONAL TENANT OBLIGATIONS

80. **The tenant agrees:**

- 80.1 to reimburse the landlord, within 30 days of being requested to do so, for:
- (a) any call out fees payable where the call out has been arranged with the tenant and the tenant has failed to provide access to the residential premises for any reason, preventing the relevant service from taking place;
 - (b) any cost or expense of any kind incurred by the landlord to replace or fix an item, fixture or fitting in or on the residential premises that was required to be replaced or fixed as a result of a fire audit or fire inspection, provided that the item, fixture or fitting needed replacing or fixing due to the activities carried out by the tenant in or on the residential premises (including, without limitation, creating holes in, or attaching hooks to, fire safety doors); and
 - (c) any fine, penalty or costs of any recovery action incurred by the landlord arising out of or in connection with the failure of a body corporate, community association or company to comply with a statutory requirement (including, without limitation, the lodgement of an annual fire safety statement) if that failure was caused or contributed to by the tenant;
- 80.2 to notify the landlord or the landlord's agent immediately if any smoke detector or smoke alarm in the residential premises is not working properly so that the landlord can attend to the landlord's obligation referred to in clause 42 of this agreement; and
- 80.3 to pay any call out fees payable to the fire brigade or other authorities which become payable in the event that a smoke alarm fitted to the residential premises is activated by activities carried out by the tenant on the residential premises, including but not limited to burning food.

ADDITIONAL TERM - TENANCY DATABASES

81. **The landlord or the landlord's agent advises and the tenant acknowledges and agrees** that the tenant's personal information may be collected, used and disclosed for the purpose of listing the tenant on a tenancy database as permitted by, and in accordance with, the provisions of the *Residential Tenancies Act 2010*.

ADDITIONAL TERM - GARAGE, STORAGE CAGE, OPEN CAR SPACE OR OTHER STORAGE FACILITY

[This clause does not apply if there is no garage, storage cage, open car space or other storage facility on the residential premises]

82. **The tenant agrees** that if the premises include a garage then the garage is provided for the purpose of parking a motor vehicle and not for the storage of goods or personal belongings.
83. **The landlord gives** no undertaking as to the security and/or waterproofing of any garage, storage cage, open car space or any other storage facility on the residential premises and accepts no liability for any damage to such garage, storage cage, open car space or other storage facility or to anything stored therein.

ADDITIONAL TERM - DETAILS OF TENANT AND TENANT'S AGENT

84. **The tenant agrees** to notify the landlord or the landlord's agent, in writing within 14 days, of any changes to the nominated contact details of the tenant or the tenant's agent, including those specified in this agreement.
85. **The landlord agrees** to provide to the tenant's agent (if appointed) all notices and documents that it gives to the tenant.

ADDITIONAL TERM - TENANT'S REFUSAL OF ACCESS

86. Where the tenant has been provided with the requisite notice pursuant to clause 24.8 and the tenant has refused access to the residential premises preventing prospective tenants from inspecting them, **the tenant acknowledges and agrees** that the landlord is entitled to claim damages for loss of bargain in the event the landlord is unable to secure a future tenant as a result of the tenant's refusal to allow access to the residential premises.
87. **The tenant agrees** that the landlord and the landlord's agent are authorised to use the office set of keys to access the residential premises for the purpose of carrying out an inspection pursuant to clause 24.

ADDITIONAL TERM - PRIVACY POLICY

88. The *Privacy Act 1988* (Cth) (the **Act**) allows certain information about the tenant referred to in this agreement to be collected, used and disclosed for the purpose for which it was collected, and otherwise in accordance with the Act. This Privacy Policy does not form part of this agreement and only applies to the extent that the landlord collects, uses and discloses personal information and is required by the Act to comply with the requirements of the Act. If the landlord appoints an agent to act for the landlord, then this Privacy Policy will apply to the landlord's agent's collection, use and disclosure of personal information on behalf of the landlord. The landlord may amend, or amend and restate, this Privacy Policy from time to time and may subsequently notify the tenant of any changes to this Privacy Policy by written notification to the tenant. Any change to this Privacy Policy takes effect on the date of that written notification. The personal information the tenant provides in connection with this agreement or collected from other sources is necessary for the landlord and (if appointed) the landlord's agent to:
- (a) identify and verify the tenant's identity;
 - (b) process and assess any application received in relation to the lease of the residential premises;
 - (c) assess the tenant's ability to meet their financial and other obligations under this agreement;
 - (d) manage this agreement and the residential premises including (without limitation) the collection of rent and the preparation of required statements of accounts;
 - (e) contact and liaise with goods and services providers as instructed by the tenant and to provide those providers with the tenant's personal information;
 - (f) comply with any applicable law;

RESIDENTIAL TENANCY AGREEMENT

- (g) liaise and exchange information with the tenant and the legal and other advisors of the tenant, landlord and (if appointed) the landlord's agent in relation to or in connection with this agreement;
- (h) negotiate the lease for the residential premises;
- (i) process any payment (including, without limitation, the exchange of personal information with the relevant payment provider, where necessary); and
- (j) comply with any dispute resolution process.

If the personal information is not provided by the tenant, the landlord and (if appointed) the landlord's agent may not be able to carry out the steps described above.

Personal information collected about the tenant may be disclosed by the landlord or (if appointed) the landlord's agent for the purpose for which it was collected, to other parties including to the landlord (if the landlord's agent is appointed), the landlord's mortgagee or head-lessor (in either case, if any), the legal and other advisors of the tenant, landlord and (if appointed) the landlord's agent, referees, valuers, other agents, Courts and

applicable tribunals, third party operators of tenancy and other databases, other third parties instructed by the tenant (including, without limitation, goods and services providers), as required by any applicable law and to any prospective or actual purchaser of the residential premises including to their prospective or actual mortgagee (if any). Personal information held by tenancy databases and relevant agencies may also be requested by and disclosed to the landlord and/or the landlord's agent. The landlord and (if appointed) the landlord's agent will take reasonable precautions to protect the personal information they hold in relation to the tenant from misuse, loss, unauthorised access, modification or disclosure.

Further, if the tenant applies for the lease of the residential premises via any third party letting business, including any online letting businesses, then the tenant will have consented to the disclosure of its personal information by that business to the landlord and (if appointed) the landlord's agent. The tenant consents to the landlord and (if appointed) the landlord's agent receiving personal information from the relevant online letting business for the purposes specified in this Privacy Policy.

If the tenant fails to comply with its obligations under this agreement, then that fact and other relevant personal information collected about the tenant during the term of this agreement may also be disclosed to third party operators of tenancy and other databases, other agents, Courts and relevant tribunals.

The landlord and (if appointed) the landlord's agent may also use the tenant's information including personal information for marketing and research purposes to inform the tenant of products and services provided by the landlord and (if appointed) the landlord's agent, which the landlord and (if appointed) the landlord's agent consider may be of value or interest to the tenant, unless the tenant tells the landlord or (if appointed) the landlord's agent (see opt out option below) or has previously told the landlord or (if appointed) the landlord's agent not to. If the tenant **does not** wish to receive any information about such products and services then please tick this box: or otherwise notify the landlord and/or landlord's agent using the contact details of the landlord and/or landlord's agent (as applicable) set out earlier in this agreement.

The tenant has the right to request access to any personal information held by the landlord and (if appointed) the landlord's agent which relates to them, unless the landlord or (if appointed) the landlord's agent is permitted by law (including the Act) to withhold that information. If the Act applies to the landlord and the landlord is an 'organisation' (as defined under the Act) then it is entitled to charge a reasonable fee where access to personal information is provided (no fee may be charged for making an application to access personal information). If an agent is appointed by the landlord, it is entitled to charge a reasonable fee where access to personal information is provided (no fee may be charged for making an application to access personal information). Any requests for access to the tenant's personal information should be made in writing to the landlord or (if appointed) the landlord's agent at the contact details included in this agreement. The tenant has the right to request the correction of any personal information which relates to the tenant that is inaccurate, incomplete or out-of-date.

By signing this agreement, the tenant acknowledges that it has read and understands the terms of this Privacy Policy and agrees to those terms and the permissions to collect, use and disclose personal information, and the tenant authorises the landlord and (if appointed) the landlord's agent to collect, use and obtain, in accordance with the Act, their personal information for the purposes specified in this Privacy Policy.

ADDITIONAL TERM - ACKNOWLEDGEMENTS

89. The landlord and tenant each acknowledge that:

- 89.1** the landlord and tenant are permitted to agree on additional terms and conditions of this agreement and to include them in an annexure at the end of this agreement;
- 89.2** the additional terms and conditions may be included in this agreement only if:
 - (a) they do not contravene the *Residential Tenancies Act 2010* (NSW), the *Residential Tenancies Regulation 2019* (NSW) or any other Act; and
 - (b) they are not inconsistent with the standard terms and conditions of this agreement; and
- 89.3** The Real Estate Institute of New South Wales Limited (REINSW) is not and cannot be responsible for the drafting and content of any additional terms and/or conditions that are included in any annexure to this agreement.

SCHEDULE A

SPECIAL CONDITIONS - FLATS

Special Condition 1 - Vehicles

The tenant must not park or stand any motor or other vehicle on common area, or permit a motor vehicle to be parked or stood on common area, except with the prior written approval of the landlord or as permitted by a sign authorised by the landlord.

Special Condition 2 - Damage to lawns and plants on the common areas

The tenant must not, except with the prior written approval of the landlord:

- (a) damage any lawn, garden, tree, shrub, plant or flower being part of or situated on the common area, or
- (b) use for his or her own purposes as a garden any portion of the common area.

Special Condition 3 - Obstruction of common areas

The tenant must not obstruct lawful use of common areas by any person except on a temporary and non-recurring basis.

Special Condition 4 - Noise

The tenant, or any invitee of the tenant, must not create any noise in the flat or the common area likely to interfere with the peaceful enjoyment of the owner or occupier of another flat or of any person lawfully using the common area.

Special Condition 5 - Behaviour of tenants and invitees

- (a) The tenant, or any invitee of the tenant, when on the common area must be adequately clothed and must not use language or behave in a manner likely to cause offence or embarrassment to the owner or occupier of another lot or to any person lawfully using the common area.
- (b) The tenant must take all reasonable steps to ensure that their invitees:
 - (i) do not behave in a manner likely to interfere with the peaceful enjoyment of the owner or occupier of another flat or any person lawfully using the common area; and
 - (ii) without limiting paragraph (b)(i), comply with Special Condition 5(a).

Special Condition 6 - Children playing on common areas in building

Any child for whom the tenant is responsible may play on any area of the common area that is designated by the landlord for that purpose but may only use an area designated for swimming while under adult supervision. The tenant must not permit any child of whom the tenant is responsible, unless accompanied by an adult exercising effective control, to be or to remain on the common area that is a laundry, car parking area or other area of possible danger or hazard to children.

Special Condition 7 - Smoke penetration

The tenant, and any invitee of the tenant, must not smoke tobacco or any other substance on the common area, except:

- (a) in an area designated as a smoking area by the landlord, or
- (b) with the written approval of the landlord.

The tenant who is permitted under this Special Condition to smoke tobacco or any other substance on common area must ensure that the smoke does not penetrate to any other flat. The tenant must ensure that smoke caused by the smoking of tobacco or any other substance by the tenant, or any invitee of the tenant, in the flat does not penetrate to the common area or any other flat.

Special Condition 8 - Preservation of fire safety

The tenant must not do any thing or permit any invitees to do any thing in the flat or common area that is likely to affect the operation of fire safety devices in the parcel or to reduce the level of fire safety in the flats or common areas.

Special Condition 9 - Storage of inflammable, dangerous or hazardous liquids and other substances and materials

- (a) The tenant must not, except with the prior written approval of the landlord, use or store in the flat, garage or carport or on the common area any inflammable, dangerous or hazardous chemical, liquid or gas or other inflammable, dangerous or hazardous material.
- (b) This Special Condition does not apply to chemicals, liquids, gases or other material used or intended to be used for domestic purposes, or any chemical, liquid, gas or other material in a fuel tank of a motor vehicle or internal combustion engine.

Special Condition 10 - Appearance of flat

- (a) The tenant must not, without the prior written approval of the landlord, maintain within the flat anything visible from outside the flat that, viewed from outside the flat, is not in keeping with the rest of the building.
- (b) This Special Condition does not apply to the hanging of any clothing, towel, bedding or other article of a similar type in accordance with Special Condition 12.

Special Condition 11 - Cleaning windows and doors

- (a) Except in circumstances referred to in Special Condition 11(b), the tenant is responsible for cleaning all interior and exterior surfaces of glass in windows and doors on the boundary of the flat, including so much as is common area.
- (b) The landlord is responsible for cleaning regularly all exterior surfaces of glass in windows and doors that cannot be accessed by the tenant safely or at all.

Special Condition 12 - Hanging out of washing

The tenant may hang any washing on any lines provided by the landlord for that purpose. The tenant may hang washing on any part of the flat other than over the balcony railings. In each case, the washing may only be hung for a reasonable period. In this Special Condition, "washing" includes any clothing, towel, bedding or other article of a similar type.

Special Condition 13 - Disposal of waste - bins for individual flats (applicable where individual flats have bins)

- (a) The tenant must:
 - (i) not deposit or throw on the common area any rubbish, dirt, dust or other material or discarded item except with the prior written approval of the landlord;
 - (ii) not deposit in a toilet, or otherwise introduce or attempt to introduce into the plumbing system, any item that is not appropriate for any such disposal (for example, a disposable nappy);
 - (iii) comply with all reasonable directions given by the landlord as to the disposal and storage of waste (including the cleaning up of spilled waste) on the common area;
 - (iv) comply with the local council's guidelines for the storage, handling, collection and disposal of waste;
 - (v) maintain bins for waste within the flat, or on any part of the common area that is authorised by the landlord, in clean and dry condition and appropriately covered;
 - (vi) not place any thing in the bins of the owner or occupier of any other flat except with the permission of that owner or occupier;
 - (vii) place the bins within an area designated for collection by the landlord not more than 12 hours before the time at which waste is normally collected and, when the waste has been collected, must promptly return the bins to the flat or other area authorised for the bins; and
 - (viii) notify the local council of any loss of, or damage to, bins provided by the local council for waste.

- (b) The landlord may give directions for the purposes of this Special Condition by posting signs on the common area with instructions on the handling of waste that are consistent with the local council's requirements or giving notices in writing to tenants.
- (c) In this Special Condition, "bin" includes any receptacle for waste and "waste" includes garbage and recyclable material.

**Special Condition 14 - Disposal of waste - shared bins
(applicable where bins are shared by flats)**

- (a) The tenant must:
 - (i) not deposit or throw on the common area any rubbish, dirt, dust or other material or discarded item except with the prior written approval of the landlord;
 - (ii) not deposit in a toilet, or otherwise introduce or attempt to introduce into the plumbing system, any item that is not appropriate for any such disposal (for example, a disposable nappy);
 - (iii) comply with all reasonable directions given by the landlord as to the disposal and storage of waste (including the cleaning up of spilled waste) on common area; and
 - (iv) comply with the local council's guidelines for the storage, handling, collection and disposal of waste.
- (b) The landlord may give directions for the purposes of this Special Condition by posting signs on the common area with instructions on the handling of waste that are consistent with the local council's requirements or giving notices in writing to tenants.
- (c) In this Special Condition, "bin" includes any receptacle for waste and "waste" includes garbage and recyclable material.

Special Condition 15 - Change in use or occupation of flat to be notified

- (a) The tenant must notify the landlord if the tenant changes the existing use of the flat.
- (b) Without limiting Special Condition 15(a), the following changes of use must be notified:
 - (i) a change that may affect the insurance premiums for the landlord (for example, if the change of use results in a hazardous activity being carried out in the flat, or results in the flat being used for commercial or industrial purposes rather than residential purposes); and
 - (i) a change to the use of the flat for short-term or holiday letting.
- (c) The notice must be given in writing at least 21 days before the change occurs or a lease or sublease commences.

Special Condition 16 - Compliance with planning and other requirements

The tenant must ensure that the flat is not used for any purpose that is prohibited by law and that the flat is not occupied by more persons than are allowed by law to occupy the flat.

NOTES.

1. Definitions

In this agreement:

landlord means the person who grants the right to occupy residential premises under this agreement, and includes a successor in title to the residential premises whose interest is subject to that of the tenant and a tenant who has granted the right to occupy residential premises to a sub-tenant.

landlord's agent means a person who acts as the agent of the landlord and who (whether or not the person carries on any other business) carries on business as an agent for:

- (a) the letting of residential premises, or
- (b) the collection of rents payable for any tenancy of residential premises.

LFAI Register means the register of residential premises that contain or have contained loose-fill asbestos insulation that is required to be maintained under Division 1A of Part 8 of the *Home Building Act 1989*.

rental bond means money paid by the tenant as security to carry out this agreement.

residential premises means any premises or part of premises (including any land occupied with the premises) used or intended to be used as a place of residence.

tenancy means the right to occupy residential premises under this agreement.

tenant means the person who has the right to occupy residential premises under this agreement, and includes the person to whom such a right passes by transfer or operation of the law and a sub-tenant of the tenant.

2. Continuation of tenancy (if fixed term agreement)

Once any fixed term of this agreement ends, the agreement continues in force on the same terms as a periodic agreement unless the agreement is terminated by the landlord or the tenant in accordance with the *Residential Tenancies Act 2010* (see notes 3 and 4).

3. Ending this agreement

This agreement may be ended by the landlord or the tenant giving written notice of termination. The tenant may give notice at any time or on certain grounds. The landlord may only give notice on certain grounds. The *Residential Tenancies Act 2010* sets out the grounds on which the landlord and the tenant may end this agreement. The grounds for the landlord ending this agreement include breach of this agreement by the tenant, sale of the residential premises requiring vacant possession, proposed sale of the residential premises, significant renovations or repairs to the residential premises, demolition of the residential premises, the residential premises ceasing to be used as rented residential premises or the landlord or the landlord's family moving into the residential premises. The grounds for the tenant ending this agreement include breach by the landlord of information disclosure provisions under the Act, section 26, breach of this agreement by the landlord or the tenant being in circumstances of domestic violence. Further grounds are set out in the Act, Parts 5 and 7.

4. Notice for ending fixed term agreement

If this agreement is a fixed term agreement, the tenant must give at least 14 days notice to end the agreement. Generally, the landlord must give at least 90 days notice, or at least 60 days notice if the agreement is for a fixed term of 6 months or less. However, the notice period is different for certain grounds for termination.

5. Notice for ending periodic agreement

If this agreement is a periodic agreement, the tenant must give at least 21 days notice to end the agreement. Generally, the landlord must give at least 90 days notice. However, the notice period is different for certain grounds for termination.

6. Warning

It is an offence for any person to obtain possession of the residential premises without an order of the Civil and Administrative Tribunal or a judgment or order of a court if the tenant does not willingly move out. A court can order fines and compensation be paid for such an offence. It is an offence for the landlord, or landlord's agent, to give a termination notice on a ground that is not genuine, to provide false or misleading supporting documents or information with a termination notice or, if an exclusion period applies, to enter into a new residential tenancy agreement of the residential premises during the exclusion period.



RESIDENTIAL TENANCY AGREEMENT



THE LANDLORD AND THE TENANT ENTER INTO THIS AGREEMENT AND AGREE TO ALL ITS TERMS.

Note. Section 9 of the *Electronic Transactions Act 2000* allows for agreements to be signed electronically in NSW if the parties consent. If an electronic signature is used then it must comply with Division 2 of Part 2 of the *Electronic Transactions Act 2000*.

SIGNED BY THE LANDLORD /LANDLORD'S AGENT

Signed by: <u>Christine Glass</u> <small>24D5388075244FD</small>		<u>7/7/2025</u>	_____
(Signature of landlord 1/landlord 1's agent)	(Date)	(Signature of landlord 2/landlord 2's agent)	(Date)

LANDLORD INFORMATION STATEMENT

The landlord acknowledges that, at or before the time of signing this residential tenancy agreement, the landlord has read and understood the contents of an information statement published by NSW Fair Trading that sets out the landlord's rights and obligations.

Signed by: <u>Christine Glass</u> <small>24D5388075244FD</small>		<u>7/7/2025</u>	_____
(Signature of landlord 1/landlord 1's agent)	(Date)	(Signature of landlord 2/landlord 2's agent)	(Date)

Note: A landlord's agent must not sign this acknowledgment unless they have first obtained from the landlord a written statement that the landlord has read and understood the contents of the information statement published by NSW Fair Trading setting out the landlord's rights and obligations.

SIGNED BY THE TENANT

DocuSigned by: <u>[Signature]</u> <small>8B2EF2D29FE6468</small>		_____
(Signature of tenant)	(Signature of tenant)	_____
<u>5/7/2025</u>	(Date)	_____
(Date)	(Date)	_____

_____	(Signature of tenant)	_____	(Signature of tenant)
_____	(Date)	_____	(Date)

TENANT INFORMATION STATEMENT

The tenant acknowledges that, at or before the time of signing this residential tenancy agreement, the tenant was given a copy of an information statement published by NSW Fair Trading.

DocuSigned by: <u>[Signature]</u> <small>8B2EF2D29FE6468</small>		_____
(Signature of tenant)	(Signature of tenant)	_____
<u>5/7/2025</u>	(Date)	_____
(Date)	(Date)	_____

_____	(Signature of tenant)	_____	(Signature of tenant)
_____	(Date)	_____	(Date)

For information about your rights and obligations as a landlord or tenant, contact:

- (a) NSW Fair Trading on 13 32 20 or www.fairtrading.nsw.gov.au, or
- (b) Law Access NSW on 1300 888 529 or www.lawaccess.nsw.gov.au, or
- (c) your local Tenants Advice and Advocacy Service at www.tenants.org.au

Tenant Information Statement

What you must know before you start renting

Starting a tenancy

Landlords or agents must give tenants this **Tenant Information Statement** before signing a residential tenancy agreement.

You should read this information statement carefully before you sign a residential tenancy agreement. Ask questions if there is anything in the agreement that you do not understand. Remember, you are entering into a legal contract with no cooling-off period. You want to be certain you understand and agree to what you are signing.

The landlord or agent must:

- ensure the property is vacant, reasonably clean, fit to live in and in good repair at the start of the tenancy
- provide and maintain the property in a reasonable state of repair
- meet health and safety laws (e.g. pool fencing, electrical installations, smoke alarms, window and balcony safety)
- ensure the property is reasonably secure
- respect your privacy and follow entry and notice requirements.

When renting you must:

- pay the rent on time
- keep the property reasonably clean and undamaged and leave it in the same condition it was in when you moved in (fair wear and tear excepted)
- not use the property for anything illegal
- follow the terms of the tenancy agreement
- respect your neighbours' right to peace, comfort and privacy.

What you must be told before you sign an agreement

Sometimes a rental property has something in its history that you should know before you sign an agreement.

The landlord or agent **must tell** you if the property is:

- planned to be sold
- subject to court proceedings where the mortgagee is trying to take possession of the property
- in a strata scheme and a strata renewal committee is currently established for the strata scheme.

The landlord or agent **must tell** you if they are aware that the property:

- has been subject to flooding from a natural weather event or bushfire in the last 5 years
- has significant health or safety risks (unless obvious to a reasonable person when the property is inspected)
- has been the scene of a serious violent crime (e.g. murder or aggravated assault) in the last 5 years
- is listed on the loose-fill asbestos insulation register
- has been used to manufacture or cultivate a prohibited drug or prohibited plant in the last 2 years
- is part of a building where a fire safety or building product rectification order (or a notice of intention to issue one of these orders) has been issued regarding external combustible cladding
- is part of a building where a development or complying development certificate application for rectification has been lodged regarding external combustible cladding
- is in a strata scheme where scheduled rectification work or major repairs will be carried out to common property during the fixed term of the agreement

- is affected by zoning or laws that will not allow you to obtain a parking permit, and only paid parking is available in the area
- is provided with any council waste services that are different to other properties in the council area
- has a driveway or walkway that others can legally use.

Penalties apply to landlords or agents if any of the above are not disclosed.

What you must be given before you sign an agreement

Before you sign an agreement or move into the property, the landlord or agent **must give** you:

- a copy of this Tenant Information Statement
- a copy of the proposed tenancy agreement, filled out in the spaces provided
- 2 hard copies, or 1 electronic copy, of the condition report for the property completed by the landlord or agent
- a copy of the by-laws, if the property is in a strata scheme.

What you must be given at the time you sign an agreement

At the time you sign the agreement, the landlord or agent **must give** you:

- for any swimming or spa pools on the property, a valid certificate of compliance or occupation certificate (issued within the last 3 years). This does not apply if you are renting a property in a strata or community scheme that has more than 2 lots.

Before or at the start of the tenancy

The landlord or agent **must give** you:

- the key (or other opening device or information) to open any lock or security device for the rented property or common property, at no cost to you or any tenant named in the agreement.

The **only** costs you can be asked to pay are:

- a holding fee (deposit) of no more than 1 weeks' rent
- up to 2 weeks' rent in advance
- up to 4 weeks' rent for the rental bond
- for agreements of 3 years or more – a fee for registering with NSW Land Registry.

The property must be fit to live in

The property must be reasonably clean, fit to live in and in a reasonable state of repair. To be fit to live in, the property must (at a minimum):

1. be structurally sound
2. have adequate natural or artificial lighting in each room, except storage rooms or garages
3. have adequate ventilation
4. be supplied with electricity or gas, and have enough electricity or gas sockets for lighting, heating and other appliances
5. have adequate plumbing and drainage
6. have a water connection that can supply hot and cold water for drinking, washing and cleaning
7. have bathroom facilities, including toilet and washing facilities, that allow users privacy.

The property could have other issues that may make it unfit for you to live in, even if it meets the above 7 minimum standards. Before you rent the property, you should tell the landlord or agent to take steps (such as make repairs) to make sure the property is fit to live in.

Residential tenancy agreement

The tenancy agreement is a legal agreement. It must include certain terms that cannot be changed or removed. It may also include additional terms. Verbal agreements are still binding on you and the landlord.

Condition report

You should have already received a copy of the condition report, completed by the landlord or agent, before you signed the agreement. This is an important piece of evidence and you should take the time to check the condition of the property at the start of the tenancy. If you do not complete the report accurately, money could be taken out of your bond (after you move out) to pay for damage that was already there when you moved in.

You must complete and give a copy of the condition report to your landlord or agent **within 7 days** after moving into the property. You must also keep a copy of the completed report.

Rent, receipts and records

Rent is a regular payment you make to the landlord to be able to live in the property. You cannot be asked to pay more than 2 weeks' rent in advance. Your landlord or agent cannot demand more rent until it is due.

Your landlord or agent can serve you with a 14 days termination notice if you are more than 14 days behind with the rent.

Your landlord or agent must:

- give you rent receipts (unless rent is paid into a bank account)
- keep a record of rent you pay
- give you a copy of the rent record within 7 days of your written request for it.

Rental bonds

The bond is money you may have to pay at the start of the tenancy as security. It must be in the form of money and not as a guarantee. Your landlord or agent can only ask for 1 bond for a tenancy agreement. The bond cannot be more than 4 weeks rent. If the landlord agrees, you can pay the bond in instalments.

Your landlord or agent must give you the option to pay your bond using Rental Bonds Online (RBO). You can use RBO to securely pay your bond direct to NSW Fair Trading using a credit card or BPAY, without the need to fill out and sign a bond lodgement form. Once registered, you can continue to use your RBO account for future tenancies.

If you decide not to use RBO, you can ask your agent or landlord for a paper bond lodgement form for you to sign, so that it can be lodged with NSW Fair Trading. The landlord must deposit any bond you pay them with NSW Fair Trading within 10 working days. If the bond is paid to the agent, the agent must deposit the bond with NSW Fair Trading within 10 working days after the end of the month in which the bond was paid.

Discrimination when applying for rental property

It is against the law for a landlord or agent to discriminate on the grounds of your race, age, disability, gender, sexual orientation, marital status or pregnancy.

If you feel that a landlord or agent has declined your tenancy application or has treated you less favourably because of any of those reasons, you can contact the NSW Anti-Discrimination Board on 1800 670 812 or the Australian Human Rights Commission on 1300 656 419.

It is not against the law if a landlord or agent chooses not to have a tenant who smokes, or has a poor tenancy history or issues with rent payments.

Communicating with your landlord or agent

Your landlord must provide you with their name and a way for you to contact them directly, even if your landlord has an agent.

This information must be given to you in writing before or when you sign the tenancy agreement, or it can be included in the agreement you sign. Your landlord must also let you know, in writing, within 14 days of any changes to their details.

Some formal communication between you and the landlord or agent must be in writing to be valid, for example, termination notices. You can use email to serve notices or other documents but only if the landlord or agent has given you permission to use their nominated email address for this purpose.

During the tenancy

Ways you can pay your rent

Your landlord or agent **must** allow you to pay your rent by:

- Electronic bank transfer (such as a funds transfer or BPAY)
- Commonwealth Government's Centrepay (this requirement to start later in 2025).

You may incur costs from your own bank, but your landlord or agent cannot charge or pass on any additional costs incurred by them if you pay your rent by one of the above options. You also **cannot** be required to use a specific service provider (such as an app) to make your payments.

Your landlord or agent can offer other ways for you to pay your rent, but you do not have to agree to these.

Can rent be increased during the tenancy?

Your rent cannot be increased in the first 12 months of your tenancy. After the first year, your landlord or agent can only increase the rent once in every 12-month period, even if your agreement is renewed or your lease type changes. This requirement continues even if the agreement is renewed or replaced as long as:

- the landlord and at least one tenant remains the same in both agreements
- the tenant hasn't moved out between agreements.

You must be given at least 60 days written notice before your rent can be increased.

Paying for electricity, gas and water usage

You may have to pay the cost for certain utilities as set out in the agreement. For example, you will pay for all:

- electricity, non-bottled gas or oil supply charges if the property is separately metered. Some exceptions apply for electricity or gas
- charges for the supply of bottled gas during the tenancy.

There are limits on when you need to pay for water usage charges. You can only be asked to pay for water usage **if** the property is separately metered (or water is delivered by vehicle) and meets the following water efficiency measures:

- all showerheads have a maximum flow rate of 9 litres per minute
- all internal cold-water taps and single mixer taps for kitchen sinks or bathroom hand basins have a maximum flow rate of 9 litres per minute
- any leaking taps or toilets on the property are fixed at the start of the agreement and whenever other water efficiency measures are installed, repaired or upgraded
- toilets are dual flush and have a minimum 3-star WELS rating.

Repairs and maintenance

The property must always be fit for you to live in. The landlord is responsible for any repairs or maintenance, so the property is in a reasonable state of repair. They must also ensure the property meets health and safety laws.

You are responsible for looking after the property and keeping it clean and undamaged. If the property includes a yard, lawns and gardens, you must also keep these areas neat and tidy.

You need to tell your landlord or the agent of any necessary repairs or damage as soon as possible. The landlord is responsible for arranging and paying for the repair costs unless you caused or allowed the damage. You are not responsible for any damage caused by a perpetrator of domestic violence during a domestic violence offence.

If the repair is an **urgent repair** e.g. where there is a burst water service, a blocked or broken toilet, a gas leak or dangerous electrical fault, your landlord or agent should organise these repairs as soon as reasonably possible after being notified. If they do not respond to an urgent repair request, you can arrange the repair yourself and the landlord must repay you up to a maximum amount of \$1,000 within 14 days of you requesting payment in writing. A list of **urgent repairs** is available at nsw.gov.au/housing-and-construction/rules/urgent-repairs-residential-rental-properties.

You can apply to NSW Fair Trading for a rectification order if your landlord refuses or does not provide and maintain the property in a reasonable state of repair. Similarly, your landlord can apply to NSW Fair Trading for a rectification order if you do not repair damage you have caused or allowed. You can also apply to the NSW Civil and Administrative Tribunal (the Tribunal) for an order if your landlord does not carry out repairs.

Smoke alarms must be working

Landlords must ensure that smoke alarms are installed on all levels of the property. Your landlord must maintain the smoke alarms in your property to ensure they are working.

You should notify your landlord or agent if a smoke alarm is not working. They are responsible for repairing (including replacing a battery) or replacing a smoke alarm within 2 business days after they become aware that it is not working.

You can choose to replace a removable battery if it needs replacing, but you must notify the landlord if and when you do this. You are not responsible for maintaining, repairing or replacing a smoke alarm. However, there are some circumstances where you can arrange for a smoke alarm to be repaired or replaced.

Privacy and access

You have the right to reasonable peace, comfort and privacy when renting. Tenancy laws restrict when and how often your landlord, agent or other authorised person can enter the property during the tenancy. Your landlord, agent or authorised person can enter the property without your consent in certain circumstances if proper notice (if applicable) is provided, for example:

- in an emergency, no notice is necessary
- if the Tribunal orders that access is allowed
- to carry out, or assess the need for, necessary repairs or maintenance of the property, if you have been given at least 2 days' notice
- to carry out urgent repairs, no notice is necessary
- to carry out repairs or replacement of a smoke alarm, if you have been given at least 1 hours' notice
- to inspect or assess the need for repair or replacement of a smoke alarm, if you have been given at least 2 business days' notice
- to carry out a general inspection of the property if you have been given at least 7 days' written notice (no more than 4 inspections are allowed during a 12-month period).

How to keep a pet on the property

You can request to keep a pet on the property by filling out a pet application form and giving it to your landlord or agent. Your landlord or agent must respond within 21 days of receiving the form. If they don't respond within this time, you can keep the pet.

Landlords or agents can only refuse consent for a pet if:

- there would be more than four animals on the property, and the number of animals is unreasonable
- the property is not suitable for the animal due to fencing, lack of open space or because it will harm the animal's welfare
- the animal is very likely to cause more damage than could be repaired using the bond
- the landlord lives at the property
- keeping the animal would break other laws, local council rules, strata or community scheme by-laws, or a residential community rule
- you did not agree to a reasonable condition on keeping the animal on the property.

There are limits on what kinds of conditions a landlord or agent can set for your pet. For example, landlords or agents cannot require an increased bond or rent as a condition. Acceptable conditions may include requiring professional carpet cleaning and pest control.

If you disagree with the landlord or agent's decision or believe the condition for consent was unreasonable, you can apply to the Tribunal to challenge this.

However, if you live in purpose-built student accommodation, your landlord can refuse a pet without a specific reason.

How to make 'minor' changes to the property

You can only make minor changes to the property with your landlord's written consent, or if the agreement allows it. Your landlord can only refuse your request if it is reasonable to do so e.g. if the work involves structural changes or is inconsistent with the nature of the property.

There are certain types of 'minor' changes where it would be unreasonable for your landlord to refuse consent. For example:

- secure furniture to a non-tiled wall for safety reasons
- fit a childproof latch to an outdoor gate in a single dwelling
- insert fly screens on windows
- install or replace internal window covering (e.g. curtains)
- install cleats or cord guides to secure blind or curtain cords
- install child safety gates inside the property
- install window safety devices for child safety (non-strata only)
- install hand-held shower heads or lever-style taps to assist elderly or disabled occupants
- install or replace hooks, nails or screws for hanging pictures etc.
- install a phone line or internet connection • plant vegetables, flowers, herbs or shrubs in the garden • install wireless removable outdoor security camera
- apply shatter-resistant film to window or glass doors
- make changes that don't penetrate a surface, or permanently modify a surface, fixture or structure of the property.

Some exceptions apply. The landlord can also require that certain minor changes be carried out by a qualified person.

You will be responsible for paying for the changes and for any damage you cause to the property. Certain rules apply for removing any modifications at the end of the tenancy.

Your rights in circumstances of domestic violence

Every person has the right to feel safe and live free from domestic violence. If you or your dependent child are experiencing domestic violence in a rental property, there are options available to you to improve your safety.

If you or your dependent child need to escape violence, you can end your tenancy immediately, without penalty.

Or, if you wish to stay in your home, you can apply to the Tribunal for an order to end the tenancy of the perpetrator (if they are another co-tenant).

A tenant or any innocent co-tenant is not liable for property damage caused by the perpetrator of violence during a domestic violence offence.

More information about dealing with domestic violence in a rental property is available on nsw.gov.au/renting-domestic-violence.

Ending the tenancy

Termination notice must be given

A tenancy agreement is a legally binding agreement that can only be ended in certain ways. A tenancy will usually be ended by you or your landlord giving notice to the other party and you vacating on or by the date specified in the notice.

If you are ending a tenancy, you need to give the landlord or agent a written termination notice with the applicable notice period. In some cases, you can apply directly to the Tribunal for a termination order without issuing a termination notice (for example if you are experiencing hardship).

If your landlord or agent is ending a tenancy, they need to give you a written termination notice in most cases. The notice must include the reason for ending the tenancy. The amount of notice you must be given will depend on the reason used. A **Termination Information Statement** must be provided with the termination notice.

If you do not leave by the date specified in the termination notice, the landlord or agent can apply to the Tribunal for termination and possession orders. If you do not comply with the Tribunal order, a Sheriff's Officer can legally remove you from the property under a warrant for possession.

You cannot be locked out of your home under any circumstances unless a Sheriff's Officer is enforcing a warrant for possession issued by the Tribunal or a court.

Ending a tenancy in circumstances of domestic violence

If you or your dependent child are in circumstances of domestic violence, you can end your tenancy immediately, without penalty. To do this you must give your landlord a domestic violence termination notice with the relevant evidence and give a domestic violence termination notice to any co-tenants.

These notices do not need to be given in person. No minimum notice period applies to a domestic violence termination notice, but it must include a termination date that is on or after the day the notice is given. If you end your tenancy by issuing a domestic violence termination notice, you cannot be listed on a tenant database.

More information about ending a tenancy due to domestic violence is available on nsw.gov.au/renting-domestic-violence.

Break fee for ending a fixed term agreement early

If you decide to end a fixed term agreement early, and the agreement is for 3 years or less, you will need to pay a break fee. The amount of the break fee will depend on how far into your lease you are when you end it. For example, the fee will be:

- 4 weeks rent if you are less than 25% through the term of your lease
- 3 weeks rent if you are at least 25% but less than halfway through the term of your lease
- 2 weeks rent if you are at least halfway but less than 75% through the term of your lease
- 1 weeks rent if you are at least 75% through the term of your lease.

The break fee does not apply if you end the agreement early for certain reasons allowed under the Act, such as when you or your dependent child are in circumstances of domestic violence.

The break fee also does not apply if your landlord gives you a termination notice, and you decide to leave before the termination date. However, to do this you must give the landlord an early exit notice with the date you will leave, and give at least 14 days' notice before you move out.

Getting the rental bond returned

You should receive the bond in full at the end of the tenancy unless there is a reason for the landlord to make a claim against the bond. The landlord can claim the bond if:

- rent or other charges (e.g. unpaid water usage bills, break fee) are owing
- copies of the keys were not given back and the locks needed to be changed
- you caused damage or did not leave the property in a reasonably clean condition compared to the original condition report, apart from 'fair wear and tear'.

You are not liable for fair wear and tear to the property that occurs over time with the use of the property, even when the property receives reasonable care and maintenance.

The condition report can be used to compare the state of the property at the start and end of the tenancy.

Checklist

You should only sign the agreement when you can answer **Yes** to the following.

The tenancy agreement

- I have read the agreement and asked questions if there were things I did not understand.
- I understand the fixed term of the agreement is negotiated before I sign, which means it can be for 6 months, 12 months, or some other period.
- I understand that any additional terms to the agreement can be negotiated before I sign.
- I have checked that all additional terms to the agreement are allowed and any terms relating to pets are reasonable conditions.

Promised repairs

For any promises the landlord or agent makes to fix anything (e.g. replace the oven, etc.) or do other work (e.g. paint a room, clean up the backyard, etc.):

- I have made sure these have already been done or
- I have a statement in writing (before signing the agreement) that they will be done.

Upfront costs

- I can **only** be asked to pay:
 - no more than 2 weeks rent in advance
 - no more than 4 weeks rent as a rental bond
 - no more than 1 weeks rent as a holding fee (deposit)
 - a fee for registering the agreement with NSW Land Registry (if 3 years or more).
- I am **not** being charged any other costs, including:
 - the cost of preparing the tenancy agreement
 - the initial supply of keys and other opening devices to each tenant named in the agreement.

Top tips for problem-free renting

Some useful tips to help avoid problems when renting:

- Keep a copy of your agreement, condition report, rent receipts, Rental Bond Number and copies of letters/ emails you send or receive in a safe place where you can easily find them later.
- Photos are a great way to record the condition of the property when you first move in. Take date-stamped photos of the property, especially areas that are damaged or unclean. Keep these photos in case the landlord objects to returning your bond at the end of your tenancy.
- Comply with the terms of your agreement and never stop paying your rent, even if you don't think the landlord is complying with their side of the agreement (e.g. by failing to do repairs). You could end up being evicted if you do.
- Never make any changes to the property, or let other people move in without asking the landlord or agent for permission first.
- Keep a written record of your dealings with the landlord or agent (for example by keeping copies of emails or a diary record of your conversations, including the times and dates, who you spoke to and what they agreed to do). It is helpful to have any agreements in writing, for example requests for repairs. This is a useful record and can also assist if there is a dispute.
- Consider taking out home contents insurance to cover your belongings in case of theft, fires and natural disasters. The landlord's building insurance, if they have it, will not cover your belongings.
- If the property has a pool or garden, be clear about what the landlord or agent expects you to do to maintain them.
- Be careful with what you sign relating to your tenancy and do not let anybody rush you. Never sign a blank form, such as a 'Claim for refund of bond' form.

More information

Visit nsw.gov.au/renting or call 13 32 20 for more information about your renting rights and responsibilities. The NSW Government funds a range of community-based Tenants Advice and Advocacy Services across NSW to provide advice, information and advocacy to tenants. Visit the Tenants' Union website at tenants.org.au.

Contact us
T: 13 32 20 W: nsw.gov.au/fair-trading For language assistance, call 13 14 50 (<i>ask for an interpreter in your language</i>)

© State of New South Wales (NSW Fair Trading), 2025.

Creative Commons Attribution 4.0 licence. For information visit fairtrading.nsw.gov.au/copyright

This publication must not be relied on as legal advice. For more information about this topic, refer to the appropriate legislation.



RESIDENTIAL TENANCY AGREEMENT

RESIDENTIAL TENANCIES REGULATION 2019



IMPORTANT INFORMATION

Please read this before completing the residential tenancy agreement (the **Agreement**).

1. This form is your written record of your tenancy agreement. This is a binding contract under the *Residential Tenancies Act 2010*, so please read all terms **and** conditions carefully.
2. If you need advice or information on your rights and responsibilities, please call NSW Fair Trading on 13 32 20 or visit www.fairtrading.nsw.gov.au before signing the Agreement.
3. If you require extra space to list additional items and terms, attach a separate sheet. All attachments should be signed and dated by both the landlord or the landlord's agent and the tenant to show that both parties have read and agree to the attachments.
4. The landlord or the landlord's agent must give the tenant a copy of the signed Agreement and any attachments, two copies or one electronic copy of the completed condition report and a copy of NSW Fair Trading's Tenant Information Statement publication.

This agreement is made on 11 / 11 / 2024 at Etalong Beach NSW Between

Landlord

[Insert name and telephone number or other contact details of landlord(s). If the landlord does not ordinarily reside in New South Wales, specify the State, Territory or, if not in Australia, country in which the landlord ordinarily resides]

Landlord 1 Name: Marc Totaro A.B.N. (if applicable):

Landlord telephone number or other contact details: marctotaro9@gmail.com

If not in NSW, the State, Territory or country (if not Australia) the landlord ordinarily resides in:

Note. These details must be provided for landlord(s), whether or not there is a landlord's agent.

[Insert name and telephone number or other contact details of landlord(s). If the landlord does not ordinarily reside in New South Wales, specify the State, Territory or, if not in Australia, country in which the landlord ordinarily resides]

Landlord 2 Name: Tom Totaro A.B.N. (if applicable):

Landlord telephone number or other contact details:

If not in NSW, the State, Territory or country (if not Australia) the landlord ordinarily resides in:

Note. These details must be provided for landlord(s), whether or not there is a landlord's agent.

[Insert business address or residential address of landlord(s)]

4/47- 49 The Esplanade

Etalong Beach NSW 2048

Note. These details must be provided for landlord(s) if there is no landlord's agent.

[Insert corporation name and business address of landlord(s) if landlord(s) is a corporation]

Tenant *[Insert name of tenant(s) and contact details]*

Tenant 1 Name Leigh Croft

Phone

Email leightc@iinet.net.au

Tenant 2 Name

Phone

Email

Tenant 3 Name

Phone

Email

Tenant 4 Name

Phone

Email

Property Address: Cabin/372 Ocean View Road, Ettalong Beach, NSW, 2257

COPYRIGHT MAY 2023

Originated and distributed by and printed and produced for the Real Estate Institute of N.S.W. in whom exclusive copyright vests.

WARNING Unauthorised reproduction in whole or in part is an infringement of Copyright.

000006699340

PAGE 1 OF 25
FM00401 - 05/23
www.reinsw.com.au



RESIDENTIAL TENANCY AGREEMENT



Landlord's agent details *[Insert name of landlord's agent (if any) and contact details]*

Licensee Mi Property Group Pty Ltd ATF Mi Property Unit Trust			
Trading as Stone Real Estate Ettalong Beach		A.B.N. 54 640 724 874	
Address Shop 4			
47-49 The Esplanade, ETTALONG BEACH, NSW		Postcode 2257	
Phone 024369-6000	Fax	Mobile 0499 990 374	Email christineglass@stonerealestate.com.au

Tenant's agent details *[Insert name of tenant's agent (if any) and contact details]*

Name /s		A.B.N.	
Address			
Postcode			
Phone	Fax	Mobile	Email

Term of agreement

The term of this agreement is:

- 6 months
- 12 months
- 2 years
- 3 years
- 5 years
- Other (please specify):
- Periodic (no end date)

starting on 18 / 11 / 2024 and ending on 16 / 11 / 2025 *[Cross out if not applicable]*

Note. For a residential tenancy agreement having a fixed term of more than 3 years, the agreement must be annexed to the form approved by the Registrar-General for registration under the *Real Property Act 1900*.

Residential Premises

The residential premises are *[Insert address]*

Address Cabin/372 Ocean View Road		
Suburb Ettalong Beach	State NSW	Postcode 2257

The residential premises include: *[Include any inclusions, for example, a parking space or furniture provided. Attach additional pages if necessary.]*

Water usage

The residential premises **do not include:** *[List anything such as a parking space, garage or storeroom which do not form part of the residential premises]*

--

Property Address:



RESIDENTIAL TENANCY AGREEMENT

Rent

The rent is \$ 340.00 per week payable in advance starting on 18 /11 /2024 .

Note. Under section 33 of the *Residential Tenancies Act 2010*, a landlord, or landlord's agent, must not require a tenant to pay more than 2 weeks rent in advance under this Agreement.

The method by which the rent must be paid:

(a) to Stone Real Estate at Ettalong Beach by cash or Electronic Funds Transfer (EFT), or

(b) into the following account, or any other account nominated by the landlord:

BSB number: 082-574 Account number: 877013182

Account name: Mi Property Group Pty Limited Unit Trust

Payment reference: 100883 , or

(c) by BPAY® in accordance with the biller code and reference number below or as otherwise provided to the tenant for that purpose:

BPAY® Biller Code: Reference Number:

(d) as follows:

Note. The landlord or landlord's agent must permit the tenant to pay the rent by at least one means for which the tenant does not incur a cost (other than bank fees or other account fees usually payable for the tenant's transactions) (see clause 4.1) and that is reasonably available to the tenant.

Rental bond *[Cross out if there is not going to be a bond]*

A rental bond of \$ already held must be paid by the tenant on signing this agreement.

The amount of the rental bond must not be more than 4 weeks rent.

The tenant provided the rental bond amount to:

- the landlord or another person, or
 the landlord's agent, or
 NSW Fair Trading through Rental Bonds Online.

Note. All rental bonds must be lodged with NSW Fair Trading. If the bond is paid to the landlord or another person, it must be deposited within 10 working days after it is paid using the Fair Trading approved form. If the bond is paid to the landlord's agent, it must be deposited within 10 working days after the end of the month in which it is paid.

IMPORTANT INFORMATION

Maximum number of occupants

No more than One persons may ordinarily live in the premises at any one time.

Urgent repairs

Nominated tradespeople for urgent repairs:

Electrical repairs: Toner Electrical Services Telephone: 0413 408 081

Plumbing repairs: Pro Coast Plumbing Telephone: 0423 643 054

Other repairs: Featon Locksmiths Telephone:

Water usage

Will the tenant be required to pay separately for water usage? Yes No If yes, see clauses 12 and 13.

Utilities

Is electricity supplied to the premises from an embedded network? Yes No

Is gas supplied to the premises from an embedded network? Yes No

For more information on consumer rights if electricity or gas is supplied from an embedded network contact NSW Fair Trading.

Property Address: Cabin/372 Ocean View Road, Ettalong Beach, NSW, 2257

COPYRIGHT MAY 2023

Originated and distributed by and printed and produced for the Real Estate Institute of N.S.W. in whom exclusive copyright vests.
WARNING Unauthorised reproduction in whole or in part is an infringement of Copyright.

000006699340

PAGE 3 OF 25
FM00401 - 05/23
www.reinsw.com.au

RESIDENTIAL TENANCY AGREEMENT

Smoke alarms

Indicate whether the smoke alarms installed in the residential premises are hardwired or battery operated:

Hardwired smoke alarm

Battery operated smoke alarm

If the smoke alarms are battery operated, are the batteries in the smoke alarms of a kind the tenant can replace?

Yes No

If yes, specify the type of battery that needs to be used if the battery in the smoke alarm needs to be replaced:

9v

If the smoke alarms are hardwired, are the back-up batteries in the smoke alarms of a kind the tenant can replace?

Yes No

If yes, specify the type of back-up battery that needs to be used if the back-up battery in the smoke alarm needs to be replaced:

If the *Strata Schemes Management Act 2015* applies to the residential premises, is the owners corporation of the strata scheme responsible for the repair and replacement of smoke alarms in the residential premises?

Yes No

Strata by-laws

Are there any strata or community scheme by-laws applicable to the residential premises? Yes No If yes, see clauses 38 and 39.

Giving notices and other documents electronically [optional] [Cross out if not applicable]

Indicate below for each person whether the person provides express consent to any notice and any other document under section 223 of the *Residential Tenancies Act 2010* being given or served on them by email. The *Electronic Transactions Act 2000* applies to notices and other documents you send or receive electronically.

[You should only consent to electronic service if you check your emails regularly. If there is more than one tenant on the agreement, all tenants should agree on a single email address for electronic service. This will help ensure co-tenants receive notices and other documents at the same time.]

Landlord

Does the landlord give express consent to the electronic service of notices and documents?

Yes No If yes, see clause 50.

[Specify email address to be used for the purpose of serving notices and documents.]

christineglass@stonerealestate.com.au

Tenant

Does the tenant give express consent to the electronic service of notices and documents?

Yes No If yes, see clause 50.

[Specify email address to be used for the purpose of serving notices and documents.]

leightc@iinet.net.au

Condition report

A condition report relating to the condition of the premises must be completed by or on behalf of the landlord before or when this agreement is given to the tenant for signing.

Tenancy laws

The *Residential Tenancies Act 2010* and the *Residential Tenancies Regulation 2019* apply to this agreement. Both the landlord and the tenant must comply with these laws.

Property Address: Cabin/372 Ocean View Road, Ettalong Beach, NSW, 2257

COPYRIGHT MAY 2023

Originated and distributed by and printed and produced for the Real Estate Institute of N.S.W. in whom exclusive copyright vests.
WARNING Unauthorised reproduction in whole or in part is an infringement of Copyright.

000006699340

PAGE 4 OF 25
FM00401 - 05/23
www.reinsw.com.au

RIGHT TO OCCUPY THE PREMISES

1. **The landlord agrees** that the tenant has the right to occupy the residential premises during the tenancy. The residential premises include the additional things (if any) noted under "**Residential premises**".

COPY OF AGREEMENT

2. **The landlord agrees** to give the tenant:
- 2.1 a copy of this agreement before or when the tenant gives the signed copy of the agreement to the landlord or landlord's agent, and
- 2.2 a copy of this agreement signed by both the landlord and the tenant as soon as is reasonably practicable.

RENT

3. **The tenant agrees:**
- 3.1 to pay rent on time, and
- 3.2 to reimburse the landlord for the cost of replacing rent deposit books or rent cards lost by the tenant, and
- 3.3 to reimburse the landlord for the amount of any fees paid by the landlord to a bank or other authorised deposit-taking institution as a result of funds of the tenant not being available for rent payment on the due date.
4. **The landlord agrees:**
- 4.1 to provide the tenant with at least one means to pay rent for which the tenant does not incur a cost (other than bank fees or other account fees usually payable for the tenant's transactions) and that is reasonably available to the tenant, and
- 4.2 not to require the tenant to pay more than 2 weeks rent in advance or to pay rent for a period of the tenancy before the end of the previous period for which rent has been paid, and
- 4.3 not to require the tenant to pay rent by a cheque or other negotiable instrument that is post-dated, and
- 4.4 to accept payment of unpaid rent after the landlord has given a termination notice on the ground of failure to pay rent if the tenant has not vacated the residential premises, and
- 4.5 not to use rent paid by the tenant for the purpose of any amount payable by the tenant other than rent, and
- 4.6 to give a rent receipt to the tenant if rent is paid in person (other than by cheque), and
- 4.7 to make a rent receipt available for collection by the tenant or to post it to the residential premises or to send it by email to an email address specified in this agreement by the tenant for the service of documents of that kind if rent is paid by cheque, and
- 4.8 to keep a record of rent paid under this agreement and to provide a written statement showing the rent record for a specified period within 7 days of a request by the tenant (unless the landlord has previously provided a statement for the same period).

Note. The landlord and the tenant may, by agreement, change the manner in which rent is payable under this agreement.

RENT INCREASES

5. **The landlord and the tenant agree** that the rent cannot be increased after the end of the fixed term (if any) of this agreement or under this agreement if the agreement is for a fixed term of 2 years or more, unless the landlord gives not less than 60 days written notice of the increase to the tenant. The notice must specify the increased rent and the day from which it is payable.

Note. Section 42 of the *Residential Tenancies Act 2010* sets out the circumstances in which rent may be increased during the fixed term of a residential tenancy agreement. An additional term for this purpose may be included in the agreement.

6. **The landlord and the tenant agree** that the rent may not be increased after the end of the fixed term (if any) of this agreement more than once in any 12-month period.
7. **The landlord and the tenant agree:**
- 7.1 that the increased rent is payable from the day specified in the notice, and
- 7.2 that the landlord may cancel or reduce the rent increase by a later notice that takes effect on the same day as the original notice, and
- 7.3 that increased rent under this agreement is not payable unless the rent is increased in accordance with this agreement and the *Residential Tenancies Act 2010* or by the Civil and Administrative Tribunal.

RENT REDUCTIONS

8. **The landlord and the tenant agree** that the rent abates if the residential premises:
- 8.1 are destroyed, or become wholly or partly uninhabitable, otherwise than as a result of a breach of this agreement, or
- 8.2 cease to be lawfully usable as a residence, or
- 8.3 are compulsorily appropriated or acquired by an authority.
9. The landlord and the tenant may, at any time during this agreement, agree to reduce the rent payable.

PAYMENT OF COUNCIL RATES, LAND TAX, WATER AND OTHER CHARGES

10. **The landlord agrees** to pay:
- 10.1 rates, taxes or charges payable under any Act (other than charges payable by the tenant under this agreement), and
- 10.2 the installation costs and charges for initial connection to the residential premises of an electricity, water, gas, bottled gas or oil supply service, and
- 10.3 all charges for the supply of electricity, non-bottled gas or oil to the tenant at the residential premises that are not separately metered, and
- Note 1.** Clause 10.3 does not apply to premises located in an embedded network in certain circumstances in accordance with clauses 34 and 35 of the *Residential Tenancies Regulation 2019*.
- Note 2.** Clause 10.3 does not apply to social housing tenancy agreements in certain circumstances, in accordance with clause 36 of the *Residential Tenancies Regulation 2019*.
- 10.4 the costs and charges for the supply or hire of gas bottles for the supply of bottled gas at the commencement of the tenancy, and
- 10.5 all charges (other than water usage charges) in connection with a water supply service to separately metered residential premises, and
- 10.6 all charges in connection with a water supply service to residential premises that are not separately metered, and
- 10.7 all charges for the supply of sewerage services (other than for pump out septic services) or the supply or use of drainage services to the residential premises, and
- 10.8 all service availability charges, however described, for the supply of non-bottled gas to the residential premises if the premises are separately metered but do not have any appliances, supplied by the landlord, for which gas is required and the tenant does not use gas supplied to the premises, and

10.9 the costs and charges for repair, maintenance or other work carried out on the residential premises which is required to facilitate the proper installation or replacement of an electricity meter, in working order, including an advanced meter, if the meter installation is required by the retailer to replace an existing meter because the meter is faulty, testing indicates the meter may become faulty or the meter has reached the end of its life.

11. The tenant agrees to pay:

11.1 all charges for the supply of electricity or oil to the tenant at the residential premises if the premises are separately metered, and

11.2 all charges for the supply of non-bottled gas to the tenant at the residential premises if the premises are separately metered, unless the premises do not have any appliances supplied by the landlord for which gas is required and the tenant does not use gas supplied to the premises, and

Note. Charges for the supply of gas in certain circumstances may also be payable by a tenant under a social housing agreement in accordance with clause 36 of the *Residential Tenancies Regulation 2019*.

11.3 all charges for the supply of bottled gas to the tenant at the residential premises except for the costs and charges for the supply or hire of gas bottles at the start of the tenancy, and

11.4 all charges for pumping out a septic system used for the residential premises, and

11.5 any excess garbage charges relating to the tenant's use of the residential premises, and

11.6 water usage charges, if the landlord has installed water efficiency measures referred to in clause 10 of the *Residential Tenancies Regulation 2019* and the residential premises:

11.6.1 are separately metered, or

11.6.2 are not connected to a water supply service and water is delivered by vehicle.

Note. Separately metered is defined in the *Residential Tenancies Act 2010*.

12. The landlord agrees that the tenant is not required to pay water usage charges unless:

12.1 the landlord gives the tenant a copy of the part of the water supply authority's bill setting out the charges, or other evidence of the cost of water used by the tenant, and

12.2 the landlord gives the tenant at least 21 days to pay the charges, and

12.3 the landlord requests payment of the charges by the tenant not later than 3 months after the issue of the bill for the charges by the water supply authority, and

12.4 the residential premises have the following water efficiency measures:

12.4.1 all internal cold water taps and single mixer taps for kitchen sinks or bathroom hand basins on the premises have a maximum flow rate of 9 litres a minute,

12.4.2 on and from 23 March 2025, all toilets are dual flush toilets that have a minimum 3 star rating in accordance with the WELS scheme,

12.4.3 all showerheads have a maximum flow rate of 9 litres a minute,

12.4.4 at the commencement of the residential tenancy agreement and whenever any other water efficiency measures are installed, repaired or upgraded, the premises are checked and any leaking taps or toilets on the premises have been fixed.

13. The landlord agrees to give the tenant the benefit of, or an amount equivalent to, any rebate received by the landlord for water usage charges payable or paid by the tenant.

POSSESSION OF THE PREMISES

14. The landlord agrees:

14.1 to make sure the residential premises are vacant so the tenant can move in on the date agreed, and

14.2 to take all reasonable steps to ensure that, at the time of signing this agreement, there is no legal reason why the premises cannot be used as a residence for the term of this agreement.

TENANT'S RIGHT TO QUIET ENJOYMENT

15. The landlord agrees:

15.1 that the tenant will have quiet enjoyment of the residential premises without interruption by the landlord or any person claiming by, through or under the landlord or having superior title to that of the landlord (such as a head landlord), and

15.2 that the landlord or the landlord's agent will not interfere with, or cause or permit any interference with, the reasonable peace, comfort or privacy of the tenant in using the residential premises, and

15.3 that the landlord or the landlord's agent will take all reasonable steps to ensure that the landlord's other neighbouring tenants do not interfere with the reasonable peace, comfort or privacy of the tenant in using the residential premises.

USE OF THE PREMISES BY TENANT

16. The tenant agrees:

16.1 not to use the residential premises, or cause or permit the premises to be used, for any illegal purpose, and

16.2 not to cause or permit a nuisance, and

16.3 not to interfere, or cause or permit interference, with the reasonable peace, comfort or privacy of neighbours, and

16.4 not to intentionally or negligently cause or permit any damage to the residential premises, and

16.5 not to cause or permit more people to reside in the residential premises than is permitted by this agreement.

17. The tenant agrees:

17.1 to keep the residential premises reasonably clean, and

17.2 to notify the landlord as soon as practicable of any damage to the residential premises, and

17.3 that the tenant is responsible to the landlord for any act or omission by a person who is lawfully on the residential premises if the person is only permitted on the premises with the tenant's consent and the act or omission would be in breach of this agreement if done or omitted by the tenant, and

17.4 that it is the tenant's responsibility to replace light globes on the residential premises.

18. The tenant agrees, when this agreement ends and before giving vacant possession of the premises to the landlord:

18.1 to remove all the tenant's goods from the residential premises, and

18.2 to leave the residential premises as nearly as possible in the same condition, fair wear and tear excepted, as at the commencement of the tenancy, and

18.3 to leave the residential premises reasonably clean, having regard to their condition at the commencement of the tenancy, and

18.4 to remove or arrange for the removal of all rubbish from the residential premises in a way that is lawful and in accordance with council requirements, and

RESIDENTIAL TENANCY AGREEMENT

- 18.5** to make sure that all light fittings on the premises have working globes, and
- 18.6** to return to the landlord all keys, and other opening devices or similar devices, provided by the landlord.

Note. Under section 54 of the *Residential Tenancies Act 2010*, the vicarious liability of a tenant for damage to residential premises caused by another person is not imposed on a tenant who is the victim of a domestic violence offence, or a co-tenant who is not a relevant domestic violence offender, if the damage occurred during the commission of a domestic violence offence (within the meaning of that Act).

LANDLORD'S GENERAL OBLIGATIONS FOR RESIDENTIAL PREMISES

19. The landlord agrees:

- 19.1** to make sure that the residential premises are reasonably clean and fit to live in, and
- Note 1.** Section 52 of the *Residential Tenancies Act 2010* specifies the minimum requirements that must be met for residential premises to be fit to live in. These include that the residential premises:
- (a) are structurally sound, and
 - (b) have adequate natural light or artificial lighting in each room of the premises other than a room that is intended to be used only for the purposes of storage or a garage, and
 - (c) have adequate ventilation, and
 - (d) are supplied with electricity or gas and have an adequate number of electricity outlet sockets or gas outlet sockets for the supply of lighting and heating to, and use of appliances in, the premises, and
 - (e) have adequate plumbing and drainage, and
 - (f) are connected to a water supply service or infrastructure that supplies water (including, but not limited to, a water bore or water tank) that is able to supply to the premises hot and cold water for drinking and ablution and cleaning activities, and
 - (g) contain bathroom facilities, including toilet and washing facilities, that allow privacy for the user.

Note 2. Premises are structurally sound only if the floors, ceilings, walls, supporting structures (including foundations), doors, windows, roof, stairs, balconies, balustrades and railings:

- (a) are in a reasonable state of repair, and
 - (b) with respect to the floors, ceilings, walls and supporting structures—are not subject to significant dampness, and
 - (c) with respect to the roof, ceilings and windows—do not allow water penetration into the premises, and
 - (d) are not liable to collapse because they are rotted or otherwise defective.
- 19.2** to make sure that all light fittings on the residential premises have working light globes on the commencement of the tenancy, and
- 19.3** to keep the residential premises in a reasonable state of repair, considering the age of, the rent paid for and the prospective life of the premises, and
- 19.4** not to interfere with the supply of gas, electricity, water, telecommunications or other services to the residential premises (unless the interference is necessary to avoid danger to any person or enable maintenance or repairs to be carried out), and

- 19.5** not to hinder a tradesperson's entry to the residential premises when the tradesperson is carrying out maintenance or repairs necessary to avoid health or safety risks to any person, or to avoid a risk that the supply of gas, electricity, water, telecommunications or other services to the residential premises may be disconnected, and
- 19.6** to comply with all statutory obligations relating to the health or safety of the residential premises, and
- 19.7** that a tenant who is the victim of a domestic violence offence or a co-tenant who is under the same agreement as the victim of the domestic violence offence but is not a relevant domestic violence offender is not responsible to the landlord for any act or omission by a co-tenant that is a breach of this agreement if the act or omission constitutes or resulted in damage to the premises and occurred during the commission of a domestic violence offence.

URGENT REPAIRS

20. The landlord agrees to pay the tenant, within 14 days after receiving written notice from the tenant, any reasonable costs (not exceeding \$1,000) that the tenant has incurred for making urgent repairs to the residential premises (of the type set out below) so long as:

- 20.1** the damage was not caused as a result of a breach of this agreement by the tenant, and
- 20.2** the tenant gives or makes a reasonable attempt to give the landlord notice of the damage, and
- 20.3** the tenant gives the landlord a reasonable opportunity to make the repairs, and
- 20.4** the tenant makes a reasonable attempt to have any appropriate tradesperson named in this agreement make the repairs, and
- 20.5** the repairs are carried out, where appropriate, by licensed or properly qualified persons, and
- 20.6** the tenant, as soon as possible, gives or tries to give the landlord written details of the repairs, including the cost and the receipts for anything the tenant pays for.

Note. The type of repairs that are *urgent repairs* are defined in the *Residential Tenancies Act 2010* and are defined as follows:

- (a) a burst water service,
- (b) an appliance, fitting or fixture that uses water or is used to supply water that is broken or not functioning properly, so that a substantial amount of water is being wasted,
- (c) a blocked or broken lavatory system,
- (d) a serious roof leak,
- (e) a gas leak,
- (f) a dangerous electrical fault,
- (g) flooding or serious flood damage,
- (h) serious storm or fire damage,
- (i) a failure or breakdown of the gas, electricity or water supply to the premises,
- (j) a failure or breakdown of any essential service on the residential premises for hot water, cooking, heating, cooling or laundering,
- (k) any fault or damage that causes the premises to be unsafe or insecure.

SALE OF THE PREMISES

21. The landlord agrees:

- 21.1** to give the tenant written notice that the landlord intends to sell the residential premises, at least 14 days before the premises are made available for inspection by potential purchasers, and

RESIDENTIAL TENANCY AGREEMENT

- 21.2 to make all reasonable efforts to agree with the tenant as to the days and times when the residential premises are to be available for inspection by potential purchasers.
22. **The tenant agrees** not to unreasonably refuse to agree to days and times when the residential premises are to be available for inspection by potential purchasers.
23. **The landlord and the tenant agree:**
- 23.1 that the tenant is not required to agree to the residential premises being available for inspection more than twice in a period of a week, and
- 23.2 that, if they fail to agree, the landlord may show the residential premises to potential purchasers not more than twice in any period of a week and must give the tenant at least 48 hours notice each time.

LANDLORD'S ACCESS TO THE PREMISES

24. **The landlord agrees** that the landlord, the landlord's agent or any person authorised in writing by the landlord, during the currency of this agreement, may only enter the residential premises in the following circumstances:
- 24.1 in an emergency (including entry for the purpose of carrying out urgent repairs),
- 24.2 if the Civil and Administrative Tribunal so orders,
- 24.3 if there is good reason for the landlord to believe the premises are abandoned,
- 24.4 if there is good reason for serious concern about the health of the tenant or any other person on the residential premises and a reasonable attempt has been made to obtain consent to the entry,
- 24.5 to inspect the premises, if the tenant is given at least 7 days written notice (no more than 4 inspections are allowed in any period of 12 months),
- 24.6 to carry out, or assess the need for, necessary repairs, if the tenant is given at least 2 days notice each time,
- 24.7 to carry out, or assess the need for, work relating to statutory health and safety obligations relating to the residential premises, if the tenant is given at least 2 days notice each time,
- 24.8 to show the premises to prospective tenants on a reasonable number of occasions if the tenant is given reasonable notice on each occasion (this is only allowed during the last 14 days of the agreement),
- 24.9 to value the property, if the tenant is given 7 days notice (not more than one valuation is allowed in any period of 12 months),
- 24.10 to take photographs, or make visual recordings, of the inside of the premises in order to advertise the premises for sale or lease, if the tenant is given reasonable notice and reasonable opportunity to move any of their possessions that can reasonably be moved out of the frame of the photograph or the scope of the recording (this is only allowed once in a 28 day period before marketing of the premises starts for sale or lease or the termination of this agreement),
- 24.11 if the tenant agrees.
25. **The landlord agrees** that a person who enters the residential premises under clause 24.5, 24.6, 24.7, 24.8, 24.9 or 24.10 of this agreement:
- 25.1 must not enter the premises on a Sunday or a public holiday, unless the tenant agrees, and
- 25.2 may enter the premises only between the hours of 8.00 a.m. and 8.00 p.m., unless the tenant agrees to another time, and
- 25.3 must not stay on the residential premises longer than is necessary to achieve the purpose of the entry to the premises, and
- 25.4 must, if practicable, notify the tenant of the proposed day and time of entry.
26. **The landlord agrees** that, except in an emergency (including to carry out urgent repairs), a person other than the landlord or the landlord's agent must produce to the tenant the landlord's or the landlord's agent's written permission to enter the residential premises.
27. **The tenant agrees** to give access to the residential premises to the landlord, the landlord's agent or any person, if they are exercising a right to enter the residential premises in accordance with this agreement.

PUBLISHING PHOTOGRAPHS OR VISUAL RECORDINGS

28. **The landlord agrees** that the landlord or the landlord's agent must not publish any photographs taken or visual recordings made of the inside of the residential premises in which the tenant's possessions are visible unless they first obtain written consent from the tenant.
- Note.** See section 55A of the *Residential Tenancies Act 2010* for when a photograph or visual recording is published.
29. **The tenant agrees** not to unreasonably withhold consent. If the tenant is in circumstances of domestic violence within the meaning of section 105B of the *Residential Tenancies Act 2010*, it is not unreasonable for the tenant to withhold consent.

FIXTURES, ALTERATIONS, ADDITIONS OR RENOVATIONS TO THE PREMISES

30. **The tenant agrees:**
- 30.1 not to install any fixture or renovate, alter or add to the residential premises without the landlord's written permission, and
- 30.2 that certain kinds of fixtures or alterations, additions or renovations that are of a minor nature specified by clause 22(2) of the *Residential Tenancies Regulation 2019* may only be carried out by a person appropriately qualified to carry out those alterations unless the landlord gives consent, and
- 30.3 to pay the cost of a fixture, installed by or on behalf of the tenant, or any renovation, alteration or addition to the residential premises, unless the landlord otherwise agrees, and
- 30.4 not to remove, without the landlord's permission, any fixture attached by the tenant that was paid for by the landlord or for which the landlord gave the tenant a benefit equivalent to the cost of the fixture, and
- 30.5 to notify the landlord of any damage caused by removing any fixture attached by the tenant, and
- 30.6 to repair any damage caused by removing the fixture or compensate the landlord for the reasonable cost of repair.
31. **The landlord agrees** not to unreasonably withhold consent to a fixture, or to an alteration, addition or renovation that is of a minor nature.

Note. The *Residential Tenancies Regulation 2019* provides a list of the kinds of fixtures or alterations, additions or renovations of a minor nature to which it would be unreasonable for a landlord to withhold consent and which of those fixtures, or alterations, additions or renovations the landlord may give consent to on the condition that the fixture or alteration, addition or renovation is carried out by an appropriately qualified person.

LOCKS AND SECURITY DEVICES

32. **The landlord agrees:**
- 32.1 to provide and maintain locks or other security devices necessary to keep the residential premises reasonably secure, and

RESIDENTIAL TENANCY AGREEMENT

- 32.2** to give each tenant under this agreement a copy of the key or opening device or information to open any lock or security device for the residential premises or common property to which the tenant is entitled to have access, and
- 32.3** not to charge the tenant for the cost of providing the copies except to recover the cost of replacement or additional copies, and
- 32.4** not to alter, remove or add any lock or other security device without reasonable excuse (which includes an emergency, an order of the Civil and Administrative Tribunal, termination of a co-tenancy or an apprehended violence order prohibiting a tenant or occupant from having access) or unless the tenant agrees, and
- 32.5** to give each tenant under this agreement a copy of any key or other opening device or information to open any lock or security device that the landlord changes as soon as practicable (and no later than 7 days) after the change.

33. The tenant agrees:

- 33.1** not to alter, remove or add any lock or other security device without reasonable excuse (which includes an emergency, an order of the Civil and Administrative Tribunal, termination of a co-tenancy or an apprehended violence order prohibiting a tenant or occupant from having access) or unless the landlord agrees, and
- 33.2** to give the landlord a copy of the key or opening device or information to open any lock or security device that the tenant changes within 7 days of the change.
- 34.** A copy of a changed key or other opening device need not be given to the other party if the other party agrees not to be given a copy or the Civil and Administrative Tribunal authorises a copy not to be given or the other party is prohibited from access to the residential premises by an apprehended violence order.

TRANSFER OF TENANCY OR SUB-LETTING BY TENANT

35. The landlord and the tenant agree that:

- 35.1** the tenant may, with the landlord's written permission, transfer the tenant's tenancy under this agreement or sub-let the residential premises, and
- 35.2** the landlord may refuse permission (whether or not it is reasonable to do so) to the transfer of the whole of the tenancy or sub-letting the whole of the residential premises, and
- 35.3** the landlord must not unreasonably refuse permission to a transfer of part of a tenancy or a sub-letting of part of the residential premises, and
- 35.4** without limiting clause 35.3, the landlord may refuse permission to a transfer of part of the tenancy or to sub-letting part of the residential premises if the number of occupants would be more than is permitted under this agreement or any proposed tenant or sub-tenant is listed on a residential tenancy database or it would result in overcrowding of the residential premises.

Note. Clauses 35.3 and 35.4 do not apply to social housing tenancy agreements.

- 36. The landlord agrees** not to charge for giving permission other than for the landlords reasonable expenses in giving permission.

CHANGE IN DETAILS OF LANDLORD OR LANDLORD'S AGENT

37. The landlord agrees:

- 37.1** if the name and telephone number or contact details of the landlord change, to give the tenant notice in writing of the change within 14 days, and
- 37.2** if the address of the landlord changes (and the landlord does not have an agent), to give the tenant notice in writing of the change within 14 days, and

- 37.3** if the name, telephone number or business address of the landlord's agent changes or the landlord appoints an agent, to give the tenant notice in writing of the change or the agent's name, telephone number and business address, as appropriate, within 14 days, and
- 37.4** if the landlord or landlord's agent is a corporation and the name or business address of the corporation changes, to give the tenant notice in writing of the change within 14 days, and
- 37.5** if the State, Territory or country in which the landlord ordinarily resides changes, to give the tenant notice in writing of the change within 14 days.

COPY OF CERTAIN BY-LAWS TO BE PROVIDED

[Cross out if not applicable]

- 38. The landlord agrees** to give to the tenant, before the tenant enters into this agreement, a copy of the by-laws applying to the residential premises if they are premises under the *Strata Schemes Management Act 2015*.
- 39. The landlord agrees** to give to the tenant, within 7 days of entering into this agreement, a copy of the by-laws applying to the residential premises if they are premises under the *Strata Schemes Development Act 2015*, the *Community Land Development Act 1989* or the *Community Land Management Act 1989*.

MITIGATION OF LOSS

- 40. The rules of law** relating to mitigation of loss or damage on breach of a contract apply to a breach of this agreement. (For example, if the tenant breaches this agreement, the landlord will not be able to claim damages for loss which could have been avoided by reasonable effort by the landlord.)

RENTAL BOND

[Cross out this clause if no rental bond is payable]

- 41. The landlord agrees** that, where the landlord or the landlord's agent applies to the Rental Bond Board or the Civil and Administrative Tribunal for payment of the whole or part of the rental bond to the landlord, the landlord or the landlord's agent will provide the tenant with:
- 41.1** details of the amount claimed, and
- 41.2** copies of any quotations, accounts and receipts that are relevant to the claim, and
- 41.3** a copy of a completed condition report about the residential premises at the end of the residential tenancy agreement.

SMOKE ALARMS

42. The landlord agrees to:

- 42.1** ensure that smoke alarms are installed in accordance with the *Environmental Planning and Assessment Act 1979* if that Act requires them to be installed in the premises and are functioning in accordance with the regulations under that Act, and
- 42.2** conduct an annual check of all smoke alarms installed on the residential premises to ensure that the smoke alarms are functioning, and
- 42.3** install or replace, or engage a person to install or replace, all removable batteries in all smoke alarms installed on the residential premises annually, except for smoke alarms that have a removable lithium battery, and
- 42.4** install or replace, or engage a person to install or replace, a removable lithium battery in a smoke alarm in the period specified by the manufacturer of the smoke alarm, and
- 42.5** engage an authorised electrician to repair or replace a hardwired smoke alarm, and

RESIDENTIAL TENANCY AGREEMENT

42.6 repair or replace a smoke alarm within 2 business days of becoming aware that the smoke alarm is not working unless the tenant notifies the landlord that the tenant will carry out the repair to the smoke alarm and the tenant carries out the repair, and

42.7 reimburse the tenant for the costs of a repair or replacement of a smoke alarm in accordance with clause 18 of the *Residential Tenancies Regulation 2019*, that the tenant is allowed to carry out.

Note 1. Under section 64A of the *Residential Tenancies Act 2010*, repairs to a smoke alarm includes maintenance of a smoke alarm in working order by installing or replacing a battery in the smoke alarm.

Note 2. Clauses 42.2–42.7 do not apply to a landlord of premises that comprise or include a lot in a strata scheme (within the meaning of the *Strata Schemes Management Act 2015*) if the owners corporation is responsible for the repair and replacement of smoke alarms in the residential premises.

Note 3. A tenant who intends to carry out a repair to a smoke alarm may do so only in the circumstances prescribed for a tenant in clause 15 of the *Residential Tenancies Regulation 2019*.

Note 4. Section 64A of the Act provides that a smoke alarm includes a heat alarm.

43. The tenant agrees:

43.1 to notify the landlord if a repair or a replacement of a smoke alarm is required, including replacing a battery in the smoke alarm, and

43.2 that the tenant may only replace a battery in a battery-operated smoke alarm, or a back-up battery in a hardwired smoke alarm, if the smoke alarm has a removable battery or a removable back-up battery, and

43.3 to give the landlord written notice, as soon as practicable if the tenant will carry out and has carried out a repair or replacement, or engages a person to carry out a repair or replacement, in accordance with clauses 15–17 of the *Residential Tenancies Regulation 2019*.

Note. Clauses 43.2 and 43.3 do not apply to tenants under social housing tenancy agreements or tenants of premises that comprise or include a lot in a strata scheme (within the meaning of the *Strata Schemes Management Act 2015*) if the owners corporation is responsible for the repair and replacement of smoke alarms in the residential premises.

44. The landlord and the tenant each agree not to remove or interfere with the operation of a smoke alarm installed on the residential premises unless they have a reasonable excuse to do so.

Note. The regulations made under the *Environmental Planning and Assessment Act 1979* provide that it is an offence to remove or interfere with the operation of a smoke alarm or a heat alarm in particular circumstances.

SWIMMING POOLS

[Cross out this clause if there is no swimming pool]

~~**45. The landlord agrees to ensure that the requirements of the Swimming Pools Act 1992 have been complied with in respect of the swimming pool on the residential premises.**~~

[Cross out the following clause if there is no swimming pool or the swimming pool is situated on land in a strata scheme (within the meaning of the Strata Schemes Management Act 2015) or in a community scheme (within the meaning of the Community Land Development Act 1989) and that strata or community scheme comprises more than 2 lots]

~~**46. The landlord agrees to ensure that at the time that this residential tenancy agreement is entered into**~~

~~**46.1. the swimming pool on the residential premises is registered under the Swimming Pools Act 1992 and has a valid certificate of compliance under that Act or a relevant occupation certificate within the meaning of that Act, and**~~

~~**46.2. a copy of that valid certificate of compliance or relevant occupation certificate is provided to the tenant**~~

Note. A swimming pool certificate of compliance is valid for 3 years from its date of issue.

LOOSE-FILL ASBESTOS INSULATION

47. The landlord agrees:

47.1 if, at the time that this residential tenancy agreement is entered into, the premises have been and remain listed on the LFAI Register, the tenant has been advised in writing by the landlord that the premises are listed on that Register, or

47.2 if, during the tenancy, the premises become listed on the LFAI Register, to advise the tenant in writing, within 14 days of the premises being listed on the Register, that the premises are listed on the Register.

COMBUSTIBLE CLADDING

48. The landlord agrees that if, during the tenancy, the landlord becomes aware of any of the following facts, the landlord will advise the tenant in writing within 14 days of becoming aware of the fact:

48.1 that the residential premises are part of a building in relation to which a notice of intention to issue a fire safety order, or a fire safety order, has been issued requiring rectification of the building regarding external combustible cladding,

48.2 that the residential premises are part of a building in relation to which a notice of intention to issue a building product rectification order, or a building product rectification order, has been issued requiring rectification of the building regarding external combustible cladding,

48.3 that the residential premises are part of a building where a development application or complying development certificate application has been lodged for rectification of the building regarding external combustible cladding.

SIGNIFICANT HEALTH OR SAFETY RISKS

49. The landlord agrees that if, during the tenancy, the landlord becomes aware that the premises are subject to a significant health or safety risk, the landlord will advise the tenant in writing, within 14 days of becoming aware, that the premises are subject to the significant health or safety risk and the nature of the risk.

ELECTRONIC SERVICE OF NOTICES AND OTHER DOCUMENTS

50. The landlord and the tenant agree:

50.1 to only serve any notices and any other documents, authorised or required by the *Residential Tenancies Act 2010* or the regulations or this agreement, on the other party by email if the other party has provided express consent, either as part of this agreement or otherwise, that a specified email address is to be used for the purpose of serving notices and other documents, and

50.2 to notify the other party in writing within 7 days if the email address specified for electronic service of notices and other documents changes, and

50.3 that they may withdraw their consent to the electronic service of notices and other documents at any time, by notifying the other party in writing, and

50.4 if a notice is given withdrawing consent to electronic service of notices and other documents, following the giving of such notice, no further notices or other documents are to be served by email.

BREAK FEE FOR FIXED TERM OF NOT MORE THAN 3 YEARS

51. The tenant agrees that, if the tenant ends the residential tenancy agreement before the end of the fixed term of the agreement, the tenant must pay a break fee of the following amount if the fixed term is not more than 3 years:

51.1 4 weeks rent if less than 25% of the fixed term has expired,



RESIDENTIAL TENANCY AGREEMENT

- 51.2 3 weeks rent if 25% or more but less than 50% of the fixed term has expired,
- 51.3 2 weeks rent if 50% or more but less than 75% of the fixed term has expired,
- 51.4 1 week's rent if 75% or more of the fixed term has expired.

This clause does not apply if the tenant terminates a fixed term residential tenancy agreement for a fixed term of more than 3 years or if the tenant terminates a residential tenancy agreement early for a reason that is permitted under the *Residential Tenancies Act 2010*.

Note. Permitted reasons for early termination include destruction of residential premises, breach of the agreement by the landlord and an offer of social housing or a place in an aged care facility, and being in circumstances of domestic violence. Section 107 of the *Residential Tenancies Act 2010* regulates the rights of the landlord and tenant under this clause.

52. **The landlord agrees** that the compensation payable by the tenant for ending the residential tenancy agreement before the end of the fixed term of not more than 3 years is limited to the amount specified in clause 51 and any occupation fee payable under the *Residential Tenancies Act 2010* for goods left on the residential premises.

Note. Section 107 of the *Residential Tenancies Act 2010* also regulates the rights of landlords and tenants for a residential tenancy agreement with a fixed term of more than 3 years.

ADDITIONAL TERMS

[Additional terms may be included in this agreement if:

- (a) both the landlord and the tenant agree to the terms, and
- (b) they do not conflict with the *Residential Tenancies Act 2010*, the *Residential Tenancies Regulation 2019* or any other Act, and
- (c) they do not conflict with the standard terms of this agreement.

ANY ADDITIONAL TERMS ARE NOT REQUIRED BY LAW AND ARE NEGOTIABLE.]

ADDITIONAL TERM - PETS

[Cross out this clause if not applicable]

~~53. The landlord agrees that the tenant may keep the following animal on the residential premises (specify the breed, size etc):~~

~~54. The tenant agrees:~~

- ~~54.1 to supervise and keep the animal within the premises, and~~
- ~~54.2 to ensure that the animal does not cause a nuisance, or breach the reasonable peace, comfort or privacy of neighbours, and~~
- ~~54.3 to ensure that the animal is registered and micro-chipped if required under law, and~~
- ~~54.4 to comply with any council requirements.~~

~~55. The tenant agrees to have the carpet professionally cleaned or to pay the cost of having the carpet professionally cleaned at the end of the tenancy if cleaning is required because an animal has been kept on the residential premises during the tenancy.~~

ADDITIONAL TERM - PETS NOT PERMITTED

[Cross out this clause if not applicable]

56. Except to the extent that another term of this agreement expressly permits the tenant to do so, the tenant must not keep, or permit to be kept, any animals on the residential premises.

ADDITIONAL TERM - MATERIAL FACTS

[Cross out this clause if not applicable]

~~57. The landlord advises the tenant of the existence of the following material fact(s) (as prescribed by the *Residential Tenancies Regulation 2019* (NSW)) in relation to the premises:~~

ADDITIONAL TERM - AGREEMENT TO USE PREVIOUS CONDITION REPORT

58. **The landlord and tenant:**

58.1 **agree** that the condition report included in a residential tenancy agreement entered into by the tenant and dated 18 / 11 / 2021 (insert a date if the landlord and tenant agree to this clause) forms part of this agreement,

58.2 **acknowledge** that the tenant's responses in that condition report form part of this agreement, and

58.3 **agree** that two physical copies of that condition report, or one electronic copy, have been given to the tenant on or before the date of this agreement.

ADDITIONAL TERM - TENANT'S CARE AND USE OF THE RESIDENTIAL PREMISES

59. Further to clauses 16 and 17 and subject to any applicable by-law, the tenant agrees:

- 59.1 to use the residential premises for residential purposes only;
- 59.2 not to use, advertise for use, sub-let, licence, transfer or otherwise part with possession of the whole or any part of the residential premises for the purpose of giving a person the right to occupy the residential premises for the purpose of a holiday, without the prior written consent of the landlord where such consent may be refused in the landlord's absolute discretion;
- 59.3 to clean the residential premises regularly with special attention to the kitchen, bathroom and appliances;
- 59.4 to put nothing down any sink, toilet or drain likely to cause obstruction or damage;
- 59.5 to wrap up and place garbage in a suitable container;
- 59.6 to regularly mow the lawns and keep the grounds and garden tidy and free of weeds and rubbish and maintain them in their condition, fair wear and tear excepted, as at the commencement of this agreement;
- 59.7 to take special care of the items let with the residential premises including any furniture, furnishings and appliances;
- 59.8 to do no decorating that involves painting, marking or defacing the residential premises or fixing posters without the prior written consent of the landlord or an order of the Civil and Administrative Tribunal;
- 59.9 to ensure that nothing is done that may prejudice any insurance policy or increase the premium payable under any insurance policy held by the landlord in relation to the residential premises and to ensure that nothing is done on the residential premises which may expose the owner to any claims or liability or which might give rise to an insurance claim;

RESIDENTIAL TENANCY AGREEMENT

- 59.10** to notify the landlord promptly of any infectious disease or the presence of rats, cockroaches, fleas or other pests;
- 59.11** to ventilate, in an adequate and timely manner and, if applicable, without any alteration or addition to the common property, all rooms and areas in the residential premises and to prevent the growth of mould;
- 59.12** not to remove, alter or damage any water efficiency measure installed in the residential premises;
- 59.13** not to store rubbish, unregistered vehicles, any inflammable, dangerous or hazardous chemical, liquid or gas (with the exception of petrol or gas stored in the fuel tank of any registered motor vehicle) or other inflammable, dangerous or hazardous material on the residential premises, and storage of any items on the residential premises is at the tenant's own risk; and
- 59.14** to take out and bring in, in accordance with the scheduled garbage collection days, and to keep clean, all bins that are supplied with the residential premises and to pay the cost of repair or replacement of any bins that become damaged, lost or stolen (if not repaired or replaced at the cost of the relevant authority) whilst the tenant is in occupation of the residential premises.

ADDITIONAL TERM - TELECOMMUNICATIONS SERVICES

60. The tenant agrees:

- 60.1** to leave, in the same manner of connection or operation, any telephone service installed in the residential premises at the commencement of this agreement; and
- 60.2** the availability of telephone or fax lines, internet services, analogue, digital or cable television (and the adequacy of such services) are the sole responsibility of the tenant and the tenant should make their own enquiries as to the availability and adequacy of such services before executing this agreement. The landlord does not warrant that any telephone or fax plugs, antenna sockets or other such sockets or service points located in the residential premises are serviceable, or will otherwise meet the requirements of the tenant, and tenants must rely upon their own enquiries. The landlord is not obliged to install any antenna, plugs or sockets including but not limited to any digital aerials or antennas or to carry out any upgrades in respect of television or internet reception on the residential premises.

ADDITIONAL TERM - RENT AND RENTAL BOND

61. The tenant agrees:

- 61.1** to pay the rent on or before the day which the term of this agreement begins; and
- 61.2** not to apply any rental bond towards payment of the rent without the prior written consent of the landlord.
- 62.** The landlord and the tenant may, by agreement, change the manner in which rent is payable under this agreement.

ADDITIONAL TERM - OCCUPANTS

63. The tenant agrees:

- 63.1** not to part with possession other than in accordance with the provisions of this agreement or the *Residential Tenancies Act 2010*; and
- 63.2** to ensure that occupants and other persons who come on to the residential premises with the tenant's consent comply with the conditions of this agreement.

ADDITIONAL TERM - TERMINATION

- 64. The tenant acknowledges** that a notice of termination does not by itself end the tenant's obligations under this agreement.

65. The tenant agrees:

- 65.1** upon termination of this agreement, to:
- (a) promptly and peacefully deliver up vacant possession of the residential premises to the landlord by the date specified in the termination notice or otherwise in accordance with the *Residential Tenancies Act 2010*;
 - (b) promptly notify the landlord or the landlord's agent of the tenant's forwarding address; and
 - (c) comply with its obligations in clause 18 of this agreement; and
- 65.2** that the tenant's obligations under this agreement continue until such time as the tenant has provided vacant possession of the residential premises, left them in the condition required under this agreement and returned to the landlord or the landlord's agent all keys, access cards, locks and other opening devices and security items.

- 66.** Notwithstanding any termination of this agreement, **the tenant acknowledges and agrees** that an application may be made to the Civil and Administrative Tribunal if the tenant does not vacate when required or otherwise does not comply with this agreement.

67. The landlord and the tenant agree that:

- 67.1** any action by the landlord or the tenant to terminate this agreement shall not affect any claim for compensation in respect of a breach of this agreement; and
- 67.2** the acceptance of or demand for rent or other money by the landlord after service of a termination notice for breach does not operate as a waiver of that notice nor does it evidence the creation of a new tenancy.

Note: Examples of where a fixed term agreement can be ended are where a party has breached the agreement (in which case the notice period is not less than 14 days) or where the rent has remained unpaid in breach of the agreement for not less than 14 days. Examples of where a periodic agreement can be ended are where a contract for sale of land requiring vacant possession has been exchanged (in which case the notice period is not less than 30 days), a party has breached the agreement (in which case the notice period is not less than 14 days) or where the rent has remained unpaid in breach of the agreement for not less than 14 days.

Note: If the tenant breaches this agreement the landlord should refer to section 87(2) of the *Residential Tenancies Act 2010*.

ADDITIONAL TERM - STATUTES, STRATA BY-LAWS, RULES AND SPECIAL CONDITIONS FOR FLATS

68. The tenant acknowledges and agrees:

- 68.1** to observe all relevant statutes, statutory regulations, strata by-laws, company title rules and community title rules relating to health, safety, noise and other housing standards with respect to the residential premises;
- 68.2** where the residential premises are subject to the *Strata Schemes Management Act 2015*, the *Strata Schemes Development Act 2015*, the *Community Land Development Act 1989* or the *Community Land Management Act 1989*, to observe and comply with any applicable strata by-laws and/or management statements and any applicable law;
- 68.3** where the residential premises are a flat (not subject to the *Strata Schemes Management Act 2015*, the *Strata Schemes Development Act 2015*, the *Community Land Development Act 1989* or the *Community Land Management Act 1989*), to comply with any applicable law and the special conditions contained in Schedule A of this agreement and any other special conditions as notified to the tenant from time to time; and
- 68.4** that, at the tenant's cost, the owners corporation or strata managing agent may dispose of abandoned goods, perishable goods or rubbish left on common property.



RESIDENTIAL TENANCY AGREEMENT



ADDITIONAL TERM - SWIMMING POOLS

(This clause does not apply when there is no pool on the residential premises)

~~60. Unless otherwise agreed by the landlord and tenant in writing, the tenant agrees:~~

- ~~60.1. to vacuum, brush and clean the pool, backwash the filter and empty the leaf bucket(s) regularly keeping them free from leaf litter and other debris;~~
- ~~60.2. to have the pool water tested once a month at a pool shop and to purchase and use the appropriate chemicals to keep the water clean and clear;~~
- ~~60.2. to keep the water level above the filter inlet at all times;~~
- ~~60.4. to notify the landlord or the landlord's agent as soon as practicable of any problems with the pool, equipment, safety gate, access door, fence or barrier;~~
- ~~60.5. not to interfere with the operation of any pool safety gate, access door, fence or barrier including not propping or holding open any safety gate or access door, nor leaving any item or object near a pool safety gate, access door, fence or barrier which would aid or allow access by children to the pool area or allow children to climb the pool safety gate, access door, fence or barrier; and~~
- ~~60.6. to ensure that the pool safety gate or access door is self-closing at all times.~~

ADDITIONAL TERM - RENT INCREASES DURING THE FIXED TERM (for a fixed term of less than 2 years):

70. By completing this clause, the parties agree that the rent will be increased during the fixed term of the agreement as follows:

70.1 the rent will be increased to

\$		per	
	on	/ /	; and

to \$		per	
	on	/ /	; or

70.2 the rent increase can be calculated by the following method (set out details):

Note: The rent payable under a fixed term agreement for a fixed term of less than 2 years must not be increased during the fixed term unless the agreement specifies the increased rent or the method of calculating the increase.

Note: Generally, the rent payable under a residential tenancy agreement may be increased only if the tenant is given written notice by the landlord or the landlord's agent specifying the increased rent and the day from which it is payable, and the notice is given at least 60 days before the increased rent is payable. This extends to an increase in the rent payable under a residential tenancy agreement on renewal of the agreement as if the increase were an increase during the term of the agreement.

ADDITIONAL TERM - RENT INCREASES DURING THE FIXED TERM (for a fixed term of 2 years or more):

71. By completing this clause, the parties agree that the rent will be increased during the fixed term of the agreement as follows:

71.1 the rent will be increased to

\$		per	
	on	/ /	; and

to \$		per	
	on	/ /	; or

71.2 the rent increase can be calculated by the following method (set out details):

Note: The rent payable under a residential tenancy agreement may be increased only if the tenant is given written notice by the landlord or the landlord's agent specifying the increased rent and the day from which it is payable, and the notice is given at least 60 days before the increased rent is payable.

Note: The rent payable under a fixed term agreement for a fixed term of 2 years or more must not be increased more than once in any period of 12 months, and may be increased whether or not the agreement sets out the amount of the increase or the method of calculating the increase.

ADDITIONAL TERM - CONDITION REPORT FORMS PART OF THIS AGREEMENT

72. For avoidance of doubt:

- 72.1 a condition report which accompanies this agreement, forms part of this agreement; and
- 72.2 a condition report that is signed by both the landlord and the tenant is presumed to be a correct statement, in the absence of evidence to the contrary, of the state of repair or general condition of the residential premises on the day specified in the report.

73. Clause 72.2 does not apply:

- 73.1 to any matter that could not have reasonably been discovered on a reasonable inspection of the residential premises; or
- 73.2 to any statement in the condition report about which the tenant makes a written dissenting comment on the copy of the report completed by the tenant and retained by the landlord.

ADDITIONAL TERM - ADDITIONAL TENANTS

74. If an Additional Tenant Annexure is attached to this agreement:

- 74.1 that document forms part of this agreement; and
- 74.2 the tenant under this agreement includes each person named in that document as a Tenant.

ADDITIONAL TERM - ADDITIONAL TENANT OBLIGATIONS

75. The tenant agrees:

- 75.1 to reimburse the landlord, within 30 days of being requested to do so, for:
 - (a) any call out fees payable where the call out has been arranged with the tenant and the tenant has failed to provide access to the residential premises for any reason, preventing the relevant service from taking place;
 - (b) any cost or expense of any kind incurred by the landlord to replace or fix an item, fixture or fitting in or on the residential premises that was required to be replaced or fixed as a result of a fire audit or fire inspection, provided that the item, fixture or fitting needed replacing or fixing due to the activities carried out by the tenant in or on the residential premises (including, without limitation, creating holes in, or attaching hooks to, fire safety doors); and
 - (c) any fine, penalty or costs of any recovery action incurred by the landlord arising out of or in connection with the failure of a body corporate, community association or company to comply with a statutory requirement (including, without limitation, the lodgement of an annual fire safety statement) if that failure was caused or contributed to by the tenant;

75.2 to notify the landlord or the landlord's agent immediately if any smoke detector or smoke alarm in the residential premises is not working properly so that the landlord can attend to the landlord's obligation referred to in clause 42 of this agreement; and

75.3 to pay any call out fees payable to the fire brigade or other authorities which become payable in the event that a smoke alarm fitted to the residential premises is activated by activities carried out by the tenant on the residential premises, including but not limited to burning food.

ADDITIONAL TERM - TENANCY DATABASES

76. The landlord or the landlord's agent advises and the tenant acknowledges and agrees that the tenant's personal information may be collected, used and disclosed for the purpose of listing the tenant on a tenancy database as permitted by, and in accordance with, the provisions of the *Residential Tenancies Act 2010*.

ADDITIONAL TERM - GARAGE, STORAGE CAGE, OPEN CAR SPACE OR OTHER STORAGE FACILITY

[This clause does not apply if there is no garage, storage cage, open car space or other storage facility on the residential premises]

77. The tenant agrees that if the premises include a garage then the garage is provided for the purpose of parking a motor vehicle and not for the storage of goods or personal belongings.

78. The landlord gives no undertaking as to the security and/or waterproofing of any garage, storage cage, open car space or any other storage facility on the residential premises and accepts no liability for any damage to such garage, storage cage, open car space or other storage facility or to anything stored therein.

ADDITIONAL TERM - DETAILS OF TENANT AND TENANT'S AGENT

79. The tenant agrees to notify the landlord or the landlord's agent, in writing within 14 days, of any changes to the nominated contact details of the tenant or the tenant's agent, including those specified in this agreement.

80. The landlord agrees to provide to the tenant's agent (if appointed) all notices and documents that it gives to the tenant.

ADDITIONAL TERM - TENANT'S REFUSAL OF ACCESS

81. Where the tenant has been provided with the requisite notice pursuant to clause 24.8 and the tenant has refused access to the residential premises preventing prospective tenants from inspecting them, **the tenant acknowledges and agrees** that the landlord is entitled to claim damages for loss of bargain in the event the landlord is unable to secure a future tenant as a result of the tenant's refusal to allow access to the residential premises.

82. The tenant agrees that the landlord and the landlord's agent are authorised to use the office set of keys to access the residential premises for the purpose of carrying out an inspection pursuant to clause 24.

ADDITIONAL TERM - PRIVACY POLICY

83. The *Privacy Act 1988* (Cth) (the **Act**) allows certain information about the tenant referred to in this agreement to be collected, used and disclosed for the purpose for which it was collected, and otherwise in accordance with the Act. This Privacy Policy does not form part of this agreement and only applies to the extent that the landlord collects, uses and discloses personal information and is required by the Act to comply with the requirements of the Act. If the landlord appoints an agent to act for the landlord, then this Privacy Policy will apply to the landlord's agent's collection, use and disclosure of personal information on behalf of the landlord.

The landlord may amend, or amend and restate, this Privacy Policy from time to time and may subsequently notify the tenant of any changes to this Privacy Policy by written notification to the tenant. Any change to this Privacy Policy takes effect on the date of that written notification.

The personal information the tenant provides in connection with this agreement or collected from other sources is necessary for the landlord and (if appointed) the landlord's agent to:

- (a) identify and verify the tenant's identity;
- (b) process and assess any application received in relation to the lease of the residential premises;
- (c) assess the tenant's ability to meet their financial and other obligations under this agreement;
- (d) manage this agreement and the residential premises including (without limitation) the collection of rent and the preparation of required statements of accounts;
- (e) contact and liaise with goods and services providers as instructed by the tenant and to provide those providers with the tenant's personal information;
- (f) comply with any applicable law;
- (g) liaise and exchange information with the tenant and the legal and other advisors of the tenant, landlord and (if appointed) the landlord's agent in relation to or in connection with this agreement;
- (h) negotiate the lease for the residential premises;
- (i) process any payment (including, without limitation, the exchange of personal information with the relevant payment provider, where necessary); and
- (j) comply with any dispute resolution process.

If the personal information is not provided by the tenant, the landlord and (if appointed) the landlord's agent may not be able to carry out the steps described above.

Personal information collected about the tenant may be disclosed by the landlord or (if appointed) the landlord's agent for the purpose for which it was collected, to other parties including to the landlord (if the landlord's agent is appointed), the landlord's mortgagee or head-lessor (in either case, if any), the legal and other advisors of the tenant, landlord and (if appointed) the landlord's agent, referees, valuers, other agents, Courts and applicable tribunals, third party operators of tenancy and other databases, other third parties instructed by the tenant (including, without limitation, goods and services providers), as required by any applicable law and to any prospective or actual purchaser of the residential premises including to their prospective or actual mortgagee (if any). Personal information held by tenancy databases and relevant agencies may also be requested by and disclosed to the landlord and/or the landlord's agent. The landlord and (if appointed) the landlord's agent will take reasonable precautions to protect the personal information they hold in relation to the tenant from misuse, loss, unauthorised access, modification or disclosure.

Further, if the tenant applies for the lease of the residential premises via any third party letting business, including any online letting businesses, then the tenant will have consented to the disclosure of its personal information by that business to the landlord and (if appointed) the landlord's agent. The tenant consents to the landlord and (if appointed) the landlord's agent receiving personal information from the relevant online letting business for the purposes specified in this Privacy Policy.

If the tenant fails to comply with its obligations under this agreement, then that fact and other relevant personal information collected about the tenant during the term of this agreement may also be disclosed to third party operators of tenancy and other databases, other agents, Courts and relevant tribunals.

The landlord and (if appointed) the landlord's agent may also use the tenant's information including personal information for marketing and research purposes to inform the tenant of products and services provided by the landlord and (if appointed) the landlord's agent, which the landlord and (if appointed) the landlord's agent consider may be of value or interest to the tenant, unless the tenant tells the landlord or (if appointed) the landlord's agent (see opt out option below) or has previously told the landlord or (if appointed) the landlord's agent not to. If the tenant **does not** wish to receive any information about such products and services then please tick this box: or otherwise notify the landlord and/or landlord's agent using the contact details of the landlord and/or landlord's agent (as applicable) set out earlier in this agreement.

The tenant has the right to request access to any personal information held by the landlord and (if appointed) the landlord's agent which relates to them, unless the landlord or (if appointed) the landlord's agent is permitted by law (including the Act) to withhold that information. If the Act applies to the landlord and the landlord is an 'organisation' (as defined under the Act) then it is entitled to charge a reasonable fee where access to personal information is provided (no fee may be charged for making an application to access personal information). If an agent is appointed by the landlord, it is entitled to charge a reasonable fee where access to personal information is provided (no fee may be charged for making an application to access personal information). Any requests for access to the tenant's personal information should be made in writing to the landlord or (if appointed) the landlord's agent at the contact details included in this agreement. The tenant has the right to request the correction of any personal information which relates to the tenant that is inaccurate, incomplete or out-of-date.

By signing this agreement, **the tenant acknowledges** that it has read and understands the terms of this Privacy Policy and agrees to those terms and the permissions to collect, use and disclose personal information, and **the tenant authorises** the landlord and (if appointed) the landlord's agent to collect, use and obtain, in accordance with the Act, their personal information for the purposes specified in this Privacy Policy.

ADDITIONAL TERM - ACKNOWLEDGEMENTS

84. The landlord and tenant each acknowledge that:

- 84.1** the landlord and tenant are permitted to agree on additional terms and conditions of this agreement and to include them in an annexure at the end of this agreement;
- 84.2** the additional terms and conditions may be included in this agreement only if:
 - (a) they do not contravene the *Residential Tenancies Act 2010* (NSW), the *Residential Tenancies Regulation 2019* (NSW) or any other Act; and
 - (b) they are not inconsistent with the standard terms and conditions of this agreement; and
- 84.3** The Real Estate Institute of New South Wales Limited (REINSW) is not and cannot be responsible for the drafting and content of any additional terms and/or conditions that are included in any annexure to this agreement.

SCHEDULE A

SPECIAL CONDITIONS - FLATS

Special Condition 1 - Vehicles

The tenant must not park or stand any motor or other vehicle on common area, or permit a motor vehicle to be parked or stood on common area, except with the prior written approval of the landlord or as permitted by a sign authorised by the landlord.

Special Condition 2 - Damage to lawns and plants on the common areas

The tenant must not, except with the prior written approval of the landlord:

- (a) damage any lawn, garden, tree, shrub, plant or flower being part of or situated on the common area, or
- (b) use for his or her own purposes as a garden any portion of the common area.

Special Condition 3 - Obstruction of common areas

The tenant must not obstruct lawful use of common areas by any person except on a temporary and non-recurring basis.

Special Condition 4 - Noise

The tenant, or any invitee of the tenant, must not create any noise in the flat or the common area likely to interfere with the peaceful enjoyment of the owner or occupier of another flat or of any person lawfully using the common area.

Special Condition 5 - Behaviour of tenants and invitees

- (a) The tenant, or any invitee of the tenant, when on the common area must be adequately clothed and must not use language or behave in a manner likely to cause offence or embarrassment to the owner or occupier of another lot or to any person lawfully using the common area.
- (b) The tenant must take all reasonable steps to ensure that their invitees:
 - (i) do not behave in a manner likely to interfere with the peaceful enjoyment of the owner or occupier of another flat or any person lawfully using the common area; and
 - (ii) without limiting paragraph (b)(i), comply with Special Condition 5(a).

Special Condition 6 - Children playing on common areas in building

Any child for whom the tenant is responsible may play on any area of the common area that is designated by the landlord for that purpose but may only use an area designated for swimming while under adult supervision. The tenant must not permit any child of whom the tenant is responsible, unless accompanied by an adult exercising effective control, to be or to remain on the common area that is a laundry, car parking area or other area of possible danger or hazard to children.

Special Condition 7 - Smoke penetration

The tenant, and any invitee of the tenant, must not smoke tobacco or any other substance on the common area, except:

- (a) in an area designated as a smoking area by the landlord, or
- (b) with the written approval of the landlord.

The tenant who is permitted under this Special Condition to smoke tobacco or any other substance on common area must ensure that the smoke does not penetrate to any other flat. The tenant must ensure that smoke caused by the smoking of tobacco or any other substance by the tenant, or any invitee of the tenant, in the flat does not penetrate to the common area or any other flat.

Special Condition 8 - Preservation of fire safety

The tenant must not do any thing or permit any invitees to do any thing in the flat or common area that is likely to affect the operation of fire safety devices in the parcel or to reduce the level of fire safety in the flats or common areas.

Special Condition 9 - Storage of inflammable, dangerous or hazardous liquids and other substances and materials

- (a) The tenant must not, except with the prior written approval of the landlord, use or store in the flat, garage or carport or on the common area any inflammable, dangerous or hazardous chemical, liquid or gas or other inflammable, dangerous or hazardous material.
- (b) This Special Condition does not apply to chemicals, liquids, gases or other material used or intended to be used for domestic purposes, or any chemical, liquid, gas or other material in a fuel tank of a motor vehicle or internal combustion engine.

Special Condition 10 - Appearance of flat

- (a) The tenant must not, without the prior written approval of the landlord, maintain within the flat anything visible from outside the flat that, viewed from outside the flat, is not in keeping with the rest of the building.
- (b) This Special Condition does not apply to the hanging of any clothing, towel, bedding or other article of a similar type in accordance with Special Condition 12.

Special Condition 11 - Cleaning windows and doors

- (a) Except in circumstances referred to in Special Condition 11(b), the tenant is responsible for cleaning all interior and exterior surfaces of glass in windows and doors on the boundary of the flat, including so much as is common area.
- (b) The landlord is responsible for cleaning regularly all exterior surfaces of glass in windows and doors that cannot be accessed by the tenant safely or at all.

Special Condition 12 - Hanging out of washing

The tenant may hang any washing on any lines provided by the landlord for that purpose. The tenant may hang washing on any part of the flat other than over the balcony railings. In each case, the washing may only be hung for a reasonable period. In this Special Condition, "washing" includes any clothing, towel, bedding or other article of a similar type.

Special Condition 13 - Disposal of waste - bins for individual flats (applicable where individual flats have bins)

- (a) The tenant must:
 - (i) not deposit or throw on the common area any rubbish, dirt, dust or other material or discarded item except with the prior written approval of the landlord;
 - (ii) not deposit in a toilet, or otherwise introduce or attempt to introduce into the plumbing system, any item that is not appropriate for any such disposal (for example, a disposable nappy);
 - (iii) comply with all reasonable directions given by the landlord as to the disposal and storage of waste (including the cleaning up of spilled waste) on the common area;
 - (iv) comply with the local council's guidelines for the storage, handling, collection and disposal of waste;
 - (v) maintain bins for waste within the flat, or on any part of the common area that is authorised by the landlord, in clean and dry condition and appropriately covered;
 - (vi) not place any thing in the bins of the owner or occupier of any other flat except with the permission of that owner or occupier;
 - (vii) place the bins within an area designated for collection by the landlord not more than 12 hours before the time at which waste is normally collected and, when the waste has been collected, must promptly return the bins to the flat or other area authorised for the bins; and
 - (viii) notify the local council of any loss of, or damage to, bins provided by the local council for waste.

- (b) The landlord may give directions for the purposes of this Special Condition by posting signs on the common area with instructions on the handling of waste that are consistent with the local council's requirements or giving notices in writing to tenants.
- (c) In this Special Condition, "bin" includes any receptacle for waste and "waste" includes garbage and recyclable material.

**Special Condition 14 - Disposal of waste - shared bins
(applicable where bins are shared by flats)**

- (a) The tenant must:
 - (i) not deposit or throw on the common area any rubbish, dirt, dust or other material or discarded item except with the prior written approval of the landlord;
 - (ii) not deposit in a toilet, or otherwise introduce or attempt to introduce into the plumbing system, any item that is not appropriate for any such disposal (for example, a disposable nappy);
 - (iii) comply with all reasonable directions given by the landlord as to the disposal and storage of waste (including the cleaning up of spilled waste) on common area; and
 - (iv) comply with the local council's guidelines for the storage, handling, collection and disposal of waste.
- (b) The landlord may give directions for the purposes of this Special Condition by posting signs on the common area with instructions on the handling of waste that are consistent with the local council's requirements or giving notices in writing to tenants.
- (c) In this Special Condition, "bin" includes any receptacle for waste and "waste" includes garbage and recyclable material.

Special Condition 15 - Change in use or occupation of flat to be notified

- (a) The tenant must notify the landlord if the tenant changes the existing use of the flat.
- (b) Without limiting Special Condition 15(a), the following changes of use must be notified:
 - (i) a change that may affect the insurance premiums for the landlord (for example, if the change of use results in a hazardous activity being carried out in the flat, or results in the flat being used for commercial or industrial purposes rather than residential purposes); and
 - (i) a change to the use of the flat for short-term or holiday letting.
- (c) The notice must be given in writing at least 21 days before the change occurs or a lease or sublease commences.

Special Condition 16 - Compliance with planning and other requirements

The tenant must ensure that the flat is not used for any purpose that is prohibited by law and that the flat is not occupied by more persons than are allowed by law to occupy the flat.

NOTES.

1. Definitions

In this agreement:

landlord means the person who grants the right to occupy residential premises under this agreement, and includes a successor in title to the residential premises whose interest is subject to that of the tenant and a tenant who has granted the right to occupy residential premises to a sub-tenant.

landlord's agent means a person who acts as the agent of the landlord and who (whether or not the person carries on any other business) carries on business as an agent for:

- (a) the letting of residential premises, or
- (b) the collection of rents payable for any tenancy of residential premises.

LFAI Register means the register of residential premises that contain or have contained loose-fill asbestos insulation that is required to be maintained under Division 1A of Part 8 of the *Home Building Act 1989*.

rental bond means money paid by the tenant as security to carry out this agreement.

residential premises means any premises or part of premises (including any land occupied with the premises) used or intended to be used as a place of residence.

tenancy means the right to occupy residential premises under this agreement.

tenant means the person who has the right to occupy residential premises under this agreement, and includes the person to whom such a right passes by transfer or operation of the law and a sub-tenant of the tenant.

2. Continuation of tenancy (if fixed term agreement)

Once any fixed term of this agreement ends, the agreement continues in force on the same terms as a periodic agreement unless the agreement is terminated by the landlord or the tenant in accordance with the *Residential Tenancies Act 2010* (see notes 3 and 4).

Clauses 5 and 6 of this agreement provide for rent to be able to be increased if the agreement continues in force, with certain restrictions.

3. Ending a fixed term agreement

If this agreement is a fixed term agreement, it may be ended by the landlord or the tenant by giving written notice of termination. The notice may be given at any time up until the end of the fixed term but cannot take effect until the term ends. The landlord must give at least 30 days notice and the tenant must give at least 14 days notice.

4. Ending a periodic agreement

If this agreement is a periodic agreement, it may be ended by the landlord or the tenant by giving written notice of termination. The notice may be given at any time. The landlord must give at least 90 days notice and the tenant must give at least 21 days notice.

5. Other grounds for ending agreement

The *Residential Tenancies Act 2010* also authorises the landlord and tenant to end this agreement on other grounds. The grounds for the landlord ending the agreement include sale of the residential premises requiring vacant possession, breach of this agreement by the tenant, due to hardship or if the agreement is frustrated because the premises are destroyed, become wholly or partly uninhabitable or cease to be lawfully usable as a residence or are appropriated or acquired by any authority by compulsory process.

The grounds for the tenant include breach by the landlord of information disclosure provisions under section 26 of the Act (not revealed when this agreement was entered into), breach of this agreement by the landlord, due to hardship or if the agreement is frustrated because the premises are destroyed, become wholly or partly uninhabitable or cease to be lawfully usable as a residence or are appropriated or acquired by any authority by compulsory process.

For more information refer to that Act or contact NSW Fair Trading on 13 32 20.

6. Warning

It is an offence for any person to obtain possession of the residential premises without an order of the Civil and Administrative Tribunal or a judgment or order of a court if the tenant does not willingly move out. A court can order fines and compensation to be paid for such an offence.



RESIDENTIAL TENANCY AGREEMENT



THE LANDLORD AND THE TENANT ENTER INTO THIS AGREEMENT AND AGREE TO ALL ITS TERMS.

Note. Section 9 of the *Electronic Transactions Act 2000* allows for agreements to be signed electronically in NSW if the parties consent. If an electronic signature is used then it must comply with Division 2 of Part 2 of the *Electronic Transactions Act 2000*.

SIGNED BY THE LANDLORD /LANDLORD'S AGENT

Signed by: Christine Glass 12/11/2024
24D5388076244FD (Signature of landlord/landlord's agent) (Date)

LANDLORD INFORMATION STATEMENT

The landlord acknowledges that, at or before the time of signing this residential tenancy agreement, the landlord has read and understood the contents of an information statement published by NSW Fair Trading that sets out the landlord's rights and obligations.

Signed by: Christine Glass 12/11/2024
24D5388076244FD (Signature of landlord/landlord's agent) (Date)

Note: A landlord's agent must not sign this acknowledgment unless they have first obtained from the landlord a written statement that the landlord has read and understood the contents of the information statement published by NSW Fair Trading setting out the landlord's rights and obligations.

SIGNED BY THE TENANT

Signed by: Ligh Craft _____
1AF0730374DE48D (Signature of tenant) (Signature of tenant)
12/11/2024 _____
(Date) (Date)

(Signature of tenant) (Signature of tenant)

(Date) (Date)

TENANT INFORMATION STATEMENT

The tenant acknowledges that, at or before the time of signing this residential tenancy agreement, the tenant was given a copy of an information statement published by NSW Fair Trading.

Signed by: Ligh Craft _____
1AF0730374DE48D (Signature of tenant) (Signature of tenant)
12/11/2024 _____
(Date) (Date)

(Signature of tenant) (Signature of tenant)

(Date) (Date)

For information about your rights and obligations as a landlord or tenant, contact:

- (a) NSW Fair Trading on 13 32 20 or www.fairtrading.nsw.gov.au, or
- (b) Law Access NSW on 1300 888 529 or www.lawaccess.nsw.gov.au, or
- (c) your local Tenants Advice and Advocacy Service at www.tenants.org.au



March 2020

Tenant information statement

What you must know before you start renting

Starting a tenancy

Landlords or agents must give all tenants a copy of this **Tenant information statement** before signing a residential tenancy agreement.

Make sure you read this information statement thoroughly before you sign a residential tenancy agreement. Ask questions if there is anything in the agreement that you do not understand.

Remember, you are committing to a legally binding contract with no cooling-off period. You want to be certain you understand and agree to what you are signing.

The landlord or agent must:

- ensure the property is vacant, reasonably clean, fit to live in and in good repair at the start of the tenancy
- provide and maintain the property in a reasonable state of repair
- meet health and safety laws (e.g. pool fencing, electrical installations, smoke alarms, window and balcony safety)
- ensure the property is reasonably secure
- respect your privacy and follow entry and notice requirements.

When renting, you must:

- pay the rent on time
- keep the property reasonably clean and undamaged and leave it in the same condition it was in when you moved in (fair wear and tear excepted)
- not use the property for anything illegal
- follow the terms of the tenancy agreement
- respect your neighbours' right to peace, comfort and privacy

What you must be told before you sign an agreement

Sometimes a rental property has something in its history that you should know before you sign an agreement.

The landlord or agent **must tell** you if the property is:

- planned to be sold
- subject to court proceedings where the mortgagee is trying to take possession of the property
- in a strata scheme and a strata renewal committee is currently established for the strata scheme.

The landlord or agent **must tell** you if they are aware of any of the following facts. If the property:

- has been subject to flooding from a natural weather event or bushfire in the last 5 years
- has significant health or safety risks (unless obvious to a reasonable person when the property is inspected)
- has been the scene of a serious violent crime (e.g. murder or aggravated assault) in the last 5 years
- is listed on the [loose-fill asbestos insulation register](#)
- has been used to manufacture or cultivate a prohibited drug or prohibited plant in the last 2 years
- is part of a building where a fire safety or building product rectification order (or a notice of intention to issue one of these orders) has been issued regarding external combustible cladding
- is part of a building where a development or complying development certificate application for rectification has been lodged regarding external combustible cladding
- is in a strata scheme where scheduled rectification work or major repairs will be carried out to common property during the fixed term of the agreement
- is affected by zoning or laws that will not allow you to obtain a parking permit, and only paid parking is available in the area
- is provided with any council waste services that are different to other properties in the council area
- has a driveway or walkway that others can legally use.

Penalties apply to landlords or agents if any of the above is not done.

What you must be given before you sign an agreement

Before you sign an agreement or move into the property, the landlord or agent **must give** you:

- a copy of this Tenant information statement
- a copy of the proposed tenancy agreement, filled out in the spaces provided
- 2 hard copies, or 1 electronic copy, of the condition report for the property completed by the landlord or agent
- a copy of the by-laws, if the property is in a strata scheme.

What you must be given at the time you sign an agreement

At the time you sign the agreement, the landlord or agent **must give** you:

- for any swimming or spa pools on the property, a valid certificate of compliance or occupation certificate (issued within the last 3 years). This does not apply if you are renting a property in a strata or community scheme that has more than 2 lots.

Before or at the start of the tenancy

The landlord or agent **must give** you:

- a copy of the key (or other opening device or information) to open any lock or security device for the rented property or common property, at no cost to you or any tenant named in the agreement

The property must be fit to live in

The property must be reasonably clean, fit to live in and in a reasonable state of repair.

To be fit to live in, the property must (at a minimum):

1. be structurally sound
2. have adequate natural or artificial lighting in each room, except storage rooms or garages
3. have adequate ventilation
4. be supplied with electricity or gas, and have enough electricity or gas sockets for lighting, heating and other appliances
5. have adequate plumbing and drainage
6. have a water connection that can supply hot and cold water for drinking, washing and cleaning
7. have bathroom facilities, including toilet and washing facilities, that allow users' privacy.

The property could have other issues that may make it unfit for you to live in, even if it meets the

above 7 minimum standards. Before you rent the property, you should tell the landlord or agent to take steps (such as make repairs) to make sure the property is fit to live in.

Residential tenancy agreement

The tenancy agreement is a legal agreement. It must include certain standard terms that cannot be changed or deleted. It may also include additional terms. Verbal agreements are still binding on you and the landlord.

Condition report

You should have already received a copy of the condition report, completed by the landlord or agent, before you signed the agreement. This is an important piece of evidence and you should take the time to check the condition of the property at the start of the tenancy. If you do not complete the report accurately, money could be taken out of your bond (after you move out) to pay for damage that was already there when you moved in.

You must complete and give a copy of the condition report to your landlord or agent **within 7 days** after moving into the property. You must also keep a copy of the completed report.

Rent, receipts and records

Rent is a regular payment you make to the landlord to be able to live in the property. You cannot be asked to pay more than 2 weeks' rent in advance. Your landlord or agent cannot demand more rent until it is due.

Your landlord or agent can serve you with 14 days' termination notice if you are more than 14 days behind with the rent.

Your landlord or agent must:

- give you rent receipts (unless rent is paid into a nominated bank account)
- keep a record of rent you pay
- provide you with a copy of the rent record within 7 days of your written request for it.

Rental bonds

The bond is money you may have to pay at the start of the tenancy as security. It must be in the form of money and not as a guarantee. Your landlord or agent can only ask for 1 bond for a tenancy agreement. The bond payable cannot be more than 4 weeks rent. If the landlord agrees, you can pay the bond in instalments.

Your landlord or agent cannot make you pay a bond before the tenancy agreement is signed. If you pay the bond directly to Fair Trading using [Rental Bonds Online](#) (RBO) the landlord or agent will receive confirmation of this before they finalise the tenancy agreement.

Your landlord or agent must give you the option to use RBO to pay your bond. You can use RBO to securely pay your bond direct to NSW Fair Trading using a credit card or BPAY, without the need to fill out and sign a bond lodgement form. Once registered, you can continue to use your RBO account for future tenancies.

If you decide not to use RBO, you can ask your agent or landlord for a paper bond lodgement form for you to sign, so that it can be lodged with Fair Trading. The landlord must deposit any bond you pay them with Fair Trading within 10 working days. If the bond is paid to the agent, the agent must deposit the bond with Fair Trading within 10 working days after the end of the month in which the bond was paid.

Discrimination when applying for rental property

It is against the law for a landlord or agent to discriminate on the grounds of your race, age, disability, gender, sexual orientation, marital status or pregnancy.

If you feel that a landlord or agent has declined your tenancy application or has treated you less favourably because of the above, you can contact the NSW Anti-Discrimination Board on 1800 670 812 or the Australian Human Rights Commission on 1300 656 419.

It is not against the law if a landlord or agent chooses not to have a tenant who smokes, or has a poor tenancy history or issues with rent payments.

Communicating with your landlord or agent

Your landlord must provide you with their name and a way for you to contact them directly, even if your landlord has an agent.

This information must be given to you in writing before or when you sign the tenancy agreement, or it can be included in the agreement you sign. Your landlord must also let you know, in writing, within 14 days of any changes to their details.

Some formal communication between you and the landlord or agent must be in writing to be valid, for example, termination notices. You can use email to serve notices or other documents but only if the landlord or agent has given you permission to use their nominated email address for this purpose.

During the tenancy

Can rent be increased during the tenancy?

For a fixed-term of less than 2 years, rent can only be increased during the fixed-term if the agreement sets out the increased amount or how the increase will be calculated. No written notice of the increase is required.

For a fixed-term of 2 years or more, or for a periodic agreement (i.e. where the fixed-term has expired or no fixed-term is specified), the rent can only be increased once in a 12-month period. You must get at least 60 days written notice.

Paying for electricity, gas and water usage

You may have to pay the cost for certain utilities as set out in the agreement. For example, you will pay for all:

- electricity, non-bottled gas or oil supply charges if the property is separately metered. Some exceptions apply for electricity or gas
- charges for the supply of bottled gas during the tenancy.

There are limits on when you need to pay for water usage charges. You can only be asked to pay for water usage if the property is separately metered (or water is delivered by vehicle) and meets the following water efficiency measures:

- all showerheads have a maximum flow rate of 9 litres per minute
- all internal cold-water taps and single mixer taps for kitchen sinks or bathroom hand basins have a maximum flow rate of 9 litres per minute
- any leaking taps or toilets on the property are fixed at the start of the agreement and whenever other water efficiency measures are installed, repaired or upgraded
- from 23 March 2025, toilets are dual flush and have a minimum 3-star WELS rating.

Repairs and maintenance

The property must always be fit for you to live in. The landlord is responsible for any repairs or maintenance, so the property is in a reasonable state of repair. They must also ensure the property meets health and safety laws.

You are responsible for looking after the property and keeping it clean and undamaged. If the property includes a yard, lawns and gardens, you must also keep these areas neat and tidy.

You need to tell your landlord or the agent of any necessary repairs or damage as soon as possible. They are responsible for arranging and paying for the repair costs unless you caused or allowed the damage. You are not responsible for any damage caused by a perpetrator of domestic violence during a domestic violence offence.

If the repair is an **urgent repair** e.g. where there is a burst water service, a blocked or broken toilet, a gas leak or dangerous electrical fault, your landlord or agent should organise these repairs as soon as reasonably possible, after being notified. If they do not respond to an urgent repair, you may be able to organise the work yourself and be reimbursed

a maximum amount of \$1,000 within 14 days from requesting payment in writing. A list of **urgent repairs** is available on the [Fair Trading website](#).

You can apply to Fair Trading for a rectification order if your landlord refuses or does not provide and maintain the property in a reasonable state of repair. Similarly, your landlord can apply to Fair Trading for a rectification order if you refuse or do not repair damage you have caused or allowed. You can also apply to the NSW Civil and Administrative Tribunal (the Tribunal) if your landlord does not carry out repairs.

Smoke alarms must be working

Landlords must ensure that smoke alarms are installed on all levels of the property. Your landlord must maintain the smoke alarms in your property to ensure they are working.

You should notify your landlord or agent if a smoke alarm is not working. They are responsible for repairing (including replacing a battery) or replacing a smoke alarm within 2 business days after they become aware that it is not working.

You can choose to replace a removable battery if it needs replacing, but you must notify the landlord if and when you do this. You are not responsible for maintaining, repairing or replacing a smoke alarm. However, there are some circumstances where you can arrange for a smoke alarm to be repaired or replaced.

Privacy and access

You have the right to reasonable peace, comfort and privacy when renting. Tenancy laws restrict when and how often your landlord, agent or other authorised person can enter the property during the tenancy. Your landlord, agent or authorised person can enter the property without your consent in certain circumstances if proper notice (if applicable) is provided.

For example:

- in an **emergency**, no notice is necessary
- if the **Tribunal orders** that access is allowed
- to carry out, or assess the need for, **necessary repairs or maintenance** of the property, if you have been given at least 2 days' notice
- to carry out **urgent repairs**, no notice is necessary
- to carry out **repairs or replacement of a smoke alarm**, if you have been given at least 1 hours' notice
- to **inspect or assess the need for repair or replacement of a smoke alarm**, if you have been given at least 2 business days' notice
- to carry out a **general inspection** of the property if you have been given at least 7 days' written notice (no more than 4 inspections during a 12-month period).

How to make 'minor' changes to the property

You can only make minor changes to the property with your landlord's written consent, or if the agreement allows it. Your landlord can only refuse your request if it is reasonable to do so e.g. if the work involves structural changes or is inconsistent with the nature of the property.

There are certain types of 'minor' changes where it would be unreasonable for your landlord to refuse consent. For example:

- secure furniture to a non-tiled wall for safety reasons
- fit a childproof latch to an outdoor gate in a single dwelling
- insert fly screens on windows
- install or replace internal window covering (e.g. curtains)
- install cleats or cord guides to secure blind or curtain cords
- install child safety gates inside the property
- install window safety devices for child safety (non-strata only)
- install hand-held shower heads or lever-style taps to assist elderly or disabled occupants
- install or replace hooks, nails or screws for hanging pictures etc.
- install a phone line or internet connection
- plant vegetables, flowers, herbs or shrubs in the garden
- install wireless removable outdoor security camera
- apply shatter-resistant film to window or glass doors
- make changes that don't penetrate a surface, or permanently modify a surface, fixture or structure of the property.

Some exceptions apply. The landlord can also require that certain minor changes be carried out by a qualified person.

You will be responsible for paying for the changes and for any damage you cause to the property. Certain rules apply for removing any modifications at the end of the tenancy.

Your rights in circumstances of domestic violence

Every person has the right to feel safe and live free from domestic violence. If you or your dependent child are experiencing domestic violence in a rental property, there are options available to you to improve your safety.

If you or your dependent child need to escape violence, you can end your tenancy immediately,

without penalty. To do this you must give your landlord a termination notice with the relevant evidence and give a termination notice to any co-tenants.

Or, if you wish to stay in your home, you can apply to the Tribunal for an order to end the tenancy of the perpetrator (if they are another co-tenant).

A tenant or any innocent co-tenant is not liable for property damage caused by the perpetrator of violence during a domestic violence offence.

Ending the tenancy

Termination notice must be given

A tenancy agreement is a legally binding agreement that can only be ended in certain ways. A tenancy will usually be ended by you or your landlord giving notice to the other party and you vacating on or after the date specified in the notice.

To end a tenancy, you need to give the landlord or agent a written termination notice with the applicable notice period. In some cases, you can apply directly to the Tribunal for a termination order without issuing a termination notice (for example if you are experiencing hardship).

If you do not leave by the date specified in the termination notice, the landlord or agent can apply to the Tribunal for termination and possession orders. If you do not comply with the Tribunal order, only a Sheriff's Officer can legally remove you from the property under a warrant for possession.

You cannot be locked out of your home under any circumstances unless a Sheriff's Officer is enforcing a warrant for possession issued by the Tribunal or a court.

Break fee for ending a fixed term agreement early

If you end a fixed term agreement early that is for 3 years or less, mandatory break fees may apply based on the stage of the agreement. If it applies, the set fee payable will be:

- 4 weeks rent if less than 25% of the lease had expired
- 3 weeks rent if 25% or more but less than 50% of the lease had expired
- 2 weeks rent if 50% or more but less than 75% of the lease had expired
- 1 week's rent if 75% or more of the lease had expired.

The break fee does not apply if you end the agreement early for a reason allowed under the Act.

Getting the rental bond returned

You should receive the bond in full at the end of the tenancy unless there is a reason for the landlord to make a claim against the bond. For example if:

- rent or other charges (e.g. unpaid water usage bills, break fee) are owing
- copies of the keys were not given back and the locks needed to be changed
- you caused damage or did not leave the property in a reasonably clean condition compared to the original condition report, apart from 'fair wear and tear'.

You are not liable for fair wear and tear to the property that occurs over time with the use of the property, even when the property receives reasonable care and maintenance.

Checklist

You should **only** sign the agreement when you can answer **Yes** to the following.

The tenancy agreement

- I have read the agreement and asked questions if there were things I did not understand.
- I understand the fixed-term of the agreement is negotiated before I sign, which means it can be for 6 months, 12 months, or some other period.
- I understand that I must be offered at least one way to pay the rent that does not involve paying a fee to a third party.
- I understand that any additional terms to the agreement can be negotiated before I sign.
- I have checked that all additional terms to the agreement are allowed. For example, the agreement does not include a term requiring me to have the carpet professionally cleaned when I leave, unless it is required because the landlord has allowed me to keep a pet on the property.

Promised repairs

For any promises the landlord or agent makes to fix anything (e.g. replace the oven, etc.) or do other work (e.g. paint a room, clean up the backyard, etc.):

- I have made sure these have already been done or
- I have an undertaking in writing (before signing the agreement) that they will be done.

Upfront costs

- I am **not** required to pay:
 - more than 2 weeks rent in advance
 - more than 4 weeks rent as a rental bond.
- I am **not** being charged for:
 - the cost of preparing the tenancy agreement
 - the initial supply of keys and other opening devices to each tenant named in the agreement
 - being allowed to keep a pet on the property.

Top tips for problem-free renting

Some useful tips to help avoid problems when renting:

- Keep a copy of your agreement, condition report, rent receipts, Rental Bond Number and copies of letters/emails you send or receive in a safe place where you can easily find them later.
- Photos are a great way to record the condition of the property when you first move in. Take date-stamped photos of the property, especially areas that are damaged or unclean. Keep these photos in case the landlord objects to returning your bond at the end of your tenancy.
- Comply with the terms of your agreement and never stop paying your rent, even if you don't think the landlord is complying with their side of the agreement (e.g. by failing to do repairs). You could end up being evicted if you do.
- Never make any changes to the property, or let other people move in without asking the landlord or agent for permission first.
- Keep a written record of your dealings with the landlord or agent (for example by keeping copies of emails or a diary record of your conversations, including the times and dates, who you spoke to and what they agreed to do). It is helpful to have any agreements in writing, for example requests for repairs. This is a useful record and can also assist if there is a dispute.

- Consider taking out home contents insurance to cover your belongings in case of theft, fires and natural disasters. The landlord's building insurance, if they have it, will not cover your belongings.
- If the property has a pool or garden, be clear about what the landlord or agent expects you to do to maintain them.
- Be careful with what you sign relating to your tenancy and do not let anybody rush you. Never sign a blank form, such as a 'Claim for refund of bond' form.
- If you are happy in the property and your agreement is going to end, consider asking for the agreement to be renewed for another fixed-term. This will remove any worry about being unexpectedly asked to leave and can help to lock in the rent for the next period.

More information

Visit the Fair Trading website or call 13 32 20 for more information about your renting rights and responsibilities. The NSW Government funds a range of community-based Tenants Advice and Advocacy Services across NSW to provide advice, information and advocacy to tenants. Visit the Tenants' Union website at tenants.org.au

fairtrading.nsw.gov.au **13 32 20**
Language assistance 13 14 50
(ask for an interpreter in your language)

© State of New South Wales (NSW Fair Trading), 2020
Creative Commons Attribution 4.0 licence.
For information: fairtrading.nsw.gov.au/copyright
This publication must not be relied on as legal advice.
For more information about this topic,
refer to the appropriate legislation.



Telephone: 1300 463 954

Please Quote: DA62060/2021

M Wales
6 Greenhaven Drive
UMINA BEACH NSW 2257

matthew@walesassociates.com.au

Notice of Determination of a Development Application
issued under the *Environmental Planning and Assessment Act 1979*
section 4.18(1)(a)

Application Number: DA62060/2021 Part 1
Applicant: M Wales
Property: LOT: 9 DP: 24978 , 372 Ocean View Road ETTALONG BEACH NSW 2257
Proposal: Dwelling Additions & Secondary Dwelling

Date from which this consent operates

In accordance with section 4.20, 8.13 of the *Environmental Planning and Assessment Act 1979*, this consent becomes effective and operates from the date of this notice.

Consent to operate from

17 November 2021

Consent to lapse on

17 November 2026

Imposition of conditions

In accordance with section 4.17 of the *Environmental Planning and Assessment Act 1979*, this consent has been granted subject to conditions of this consent.

Review of Determination

In accordance with section 8.2, 8.3, 8.4, 8.5 of the *Environmental Planning and Assessment Act 1979*, the applicant may make an application seeking a review of this determination, providing it is made in time for Council to determine the review within six (6) months of this determination.

Right of Appeal

Section 8.7, 8.10 of the *Environmental Planning and Assessment Act 1979* confers on an applicant, who is dissatisfied with the determination of a consent authority, a right of appeal to the Land and Environment Court within six (6) months from the date of determination. To ascertain the date upon which the determination becomes effective refer to section 4.20, 8.13 of the Act.

For further information contact Central Coast Council Customer Service Unit on 1300 463 954.

On behalf of the consent authority
David Farmer
Chief Executive Officer

Per: 

Date: 17/11/2021

Conditions

1. PARAMETERS OF THIS CONSENT

1.1 Approved Plans and Supporting Documents

Implement the development substantially in accordance with the plans and supporting documents listed below as submitted by the applicant and to which is affixed a Council stamp "*Development Consent*" unless modified by any following condition.

Architectural Plans by: Howard Leslie & Associates

Drawing	Description	Sheets	Issue	Date
20697	Architectural plan set	1 to 23	03	20/10/2021

Supporting Documentation:

Nil

- 1.2 Carry out all building works in accordance with the National Construction Code Series, Building Code of Australia, Volume 1 and 2 as appropriate.
- 1.3 Comply with all commitments listed in the BASIX Certificate for the development as required under clause 97A of the Environmental Planning and Assessment Regulation 2000.

2. PRIOR TO ISSUE OF ANY CONSTRUCTION CERTIFICATE

- 2.1 All conditions under this section must be met prior to the issue of any Construction Certificate.

- 2.2 Pursuant to Section 7.11 of the *Environmental Planning and Assessment Act 1979*, pay to Council a total contribution amount of \$ 8,566.00 that may require adjustment at the time of payment, in accordance with the relevant Council Contribution Plans No. 31A, 31B, 31C & 31D - Peninsula.

Roadworks - Capital	B	(Key No 789)	\$457.00
Open Space - Land	C	(Key No 791)	\$1,470.00
Open Space - Embellishment	C	(Key No 790)	\$4,170.00
Community Facilities - Land	D	(Key No 793)	\$72.00
Community Facilities - Capital	D	(Key No 792)	\$1,169.00
Drainage - Land	A	(Key No 787)	\$244.00
Drainage - Capital	A	(Key No 788)	\$984.00
TOTAL AMOUNT			\$8,566.00

The total amount must be indexed each quarter in accordance with the Consumer Price Index (All Groups Index) for Sydney issued by the Australian Statistician as outlined in the contributions plan.

Contact Council's Contributions Planner on Tel 1300 463 954 for an up-to-date contribution payment amount.

Any Construction Certificate must not be issued until the developer has provided the Certifier with a copy of a receipt issued by Council that verifies that the contributions have been paid. A copy of this receipt must accompany the documents submitted by the Certifier to Council under Clause 104 of the *Environmental Planning and Assessment Regulation 2000*.

A copy of the Contribution Plan may be inspected at the office of Central Coast Council, 49 Mann Street Gosford or on Council's website:

Development Contributions - former Gosford LGA

- 2.3 No activity is to be carried out on-site until the Construction Certificate has been issued, other than:
- Site investigation for the preparation of the construction, and / or
 - Implementation of environmental protection measures, such as erosion control and the like that are required by this consent
 - Demolition
- 2.4 Submit engineering details prepared and certified by a practising structural engineer that comply with *Council's Building Over or Adjacent To Sewer and Water Main Guidelines* to the satisfaction of Council. Engineering details must be submitted to Council's Water Assessment Team for approval. Plan assessment fees apply.
- 2.5 Submit an application to Council under section 305 of the Water Management Act 2000 for a section 307 certificate of compliance. The Application form can be found on Council's website centralcoast.nsw.gov.au. Early application is recommended.

The section 305 application will result in a section 306 letter of requirements which must be obtained prior to the issue of any Construction Certificate. The requirements letter will outline which requirements must be met prior to each development milestone eg. prior to construction certificate, subdivision works certificate, occupation certificate and/or subdivision certificate.

3. PRIOR TO COMMENCEMENT OF ANY WORKS

- 3.1 All conditions under this section must be met prior to the commencement of any works.

- 3.2** Appoint a Principal Certifier for the building work:
- a. The Principal Certifier (if not Council) is to notify Council of their appointment and notify the person having the benefit of the development consent of any critical stage inspections and other inspections that are to be carried out in respect of the building work no later than two (2) days before the building work commences.
 - b. Submit to Council a Notice of Commencement of Building Work form giving at least two (2) days' notice of the intention to commence building work. The forms can be found on Council's website: www.centralcoast.nsw.gov.au
- 3.3** Erect a sign in a prominent position on any work site on which building, subdivision or demolition work is being carried out. The sign must indicate:
- a. The name, address and telephone number of the Principal Certifier for the work; and
 - b. The name of the principal contractor and a telephone number at which that person can be contacted outside of working hours; and
 - c. That unauthorised entry to the work site is prohibited
 - d. Remove the sign when the work has been completed.
- 3.4** Submit both a Plumbing and Drainage Inspection Application, with the relevant fee, and a Plumbing and Drainage Notice of Work in accordance with the Plumbing and Drainage Act 2011 (to be provided by licensed plumber). These documents can be found on Council's website at: www.centralcoast.nsw.gov.au
- Contact Council prior to submitting these forms to confirm the relevant fees.
- This condition only applies if installation / alteration of plumbing and / or drainage works proposed (excludes stormwater drainage). This condition does not apply to swimming pool plumbing that does not physically connect / break into the sewer system.
- 3.5** Provide and maintain a garbage receptacle at the work site until the works are completed. The garbage receptacle must have a tight fitting lid and be suitable for food scraps and papers.
- 3.6** Install run-off and erosion controls to prevent soil erosion, water pollution or the discharge of loose sediment on the surrounding land by:
- a. erecting a silt fence and providing any other necessary sediment control measures that will prevent debris escaping into drainage systems, waterways or adjoining properties, and
 - b. diverting uncontaminated run-off around cleared or disturbed areas, and
 - c. preventing the tracking of sediment by vehicles onto roads, and
 - d. stockpiling top soil, excavated materials, construction and landscaping supplies and debris within the lot
- 3.7** Disconnect, seal and make safe all existing site services prior to the commencement of any demolition on the site. Sewer and water services must be disconnected by a licensed plumber and drainer with a Start Work Docket submitted to Council's Plumbing and Drainage Inspector as the Water and Sewer Authority.

- 3.8** Erect a temporary hoarding or temporary construction site fence between the work site and adjoining lands before the works begin and must be kept in place until after the completion of the works, if the works:
- could cause a danger, obstruction or inconvenience to pedestrian or vehicular traffic, or
 - could cause damage to adjoining lands by falling objects, or
 - involve the enclosure of a public place or part of a public place

Note 1: A structure on public land or on or over a public road requires the prior approval of the relevant authority under the *Local Government Act 1993* or the *Roads Act 1993*, respectively.

Note 2: The *Work Health and Safety Act 2011* and *Work Health and Safety Regulation 2011* contain provisions relating to scaffolds, hoardings and other temporary structures.

- 3.9** Provide or make available toilet facilities at the work site before works begin and maintain the facilities until the works are completed at a ratio of one toilet plus one additional toilet for every twenty (20) persons employed at the site.

Each toilet must:

- be a standard flushing toilet connected to a public sewer, or
 - have an on-site effluent disposal system approved under the *Local Government Act 1993*, or
 - be a temporary chemical closet approved under the *Local Government Act 1993*
- 3.10** Undertake any demolition involving asbestos in accordance with the *Work Health and Safety Act 2011*.

The person having the benefit of this consent must ensure that the removal of:

- more than 10m² of non-friable asbestos or asbestos containing material is carried out by a licensed non-friable (Class B) or a friable (Class A) asbestos removalist, and
- friable asbestos of any quantity is removed by a licensed removalist with a friable (Class A) asbestos removal licence

The licensed asbestos removalist must give notice to the regulator before work commences in accordance with Clause 466 of the *Work Health and Safety Regulation 2011*.

4. DURING WORKS

- 4.1** All conditions under this section must be met during works.

- 4.2** Carry out construction or demolition works during the construction phase of the development only between the hours as follows:

- 7.00am and 5.00pm Monday to Saturday

No construction or demolition works associated with the development are permitted to be carried out at any time on a Sunday or a public holiday.

- 4.3** During the construction phase of the development, if any Aboriginal object (including evidence of habitation or remains), is discovered during the course of the work:
- All excavation or disturbance of the area must stop immediately in that area, and
 - The Office of Environment and Heritage must be advised of the discovery in accordance with section 89A of the National Parks and Wildlife Act 1974.

Note: If an Aboriginal object is discovered, an Aboriginal heritage impact permit may be required under the National Parks and Wildlife Act 1974.

- 4.4** Implement and maintain all erosion and sediment control measures at or above design capacity for the duration of the construction works and until such time as all ground disturbed by the works has been stabilised and rehabilitated so that it no longer acts as a source of sediment.
- 4.5** Keep a copy of the stamped approved plans on-site for the duration of site works and make the plans available upon request to either the Principal Certifier or an officer of Council.
- 4.6** Notify Council when plumbing and drainage work will be ready for inspection(s) and make the work accessible for inspection in accordance with the Plumbing and Drainage Act 2011.

This condition only applies if installation / alteration of plumbing and / or drainage works proposed (excludes stormwater drainage).

- 4.7** Place all building materials, plant and equipment on the site of the development during the construction phase of the development so as to ensure that pedestrian and vehicular access within adjoining public roads, footpaths and reserve areas, is not restricted and to prevent damage to public infrastructure. Further, no construction work is permitted to be carried out within the road reserve unless the works are associated with a separate approval issued under the provisions of the *Roads Act 1993*.
- 4.8** Re-use, recycle or dispose of all building materials in accordance with the Waste Management Plan submitted with the subject application.
- 4.9** Demolish all buildings and / or building components in a safe and systematic manner in accordance with Australian Standard AS 2601-2001: *The demolition of structures*. Waste materials must be disposed of at a waste management facility.
- 4.10** No fill other than that as indicated within the approved plans is permitted to be placed upon the site.
- 4.11** Do not access the development site through a public reserve unless approval for temporary access over the public reserve is obtained from the council as the Land Manager. A copy of the approval must be available for viewing on-site at all times during work.

5. PRIOR TO ISSUE OF ANY OCCUPATION CERTIFICATE

- 5.1** All conditions under this section must be met prior to the issue of any Occupation Certificate.
- 5.2** Submit a Certificate of Compliance for all plumbing and drainage work and a Sewer Service Diagram showing sanitary drainage work (to be provided by licensed plumber) in accordance with the Plumbing and Drainage Act 2011.
- This condition only applies if installation / alteration of plumbing and / or drainage works proposed (excludes stormwater drainage).
- 5.3** Prior to the occupation or use of the building/structure, an application for an Occupation Certificate for the development must be submitted to and approved by the Principal Certifier. The Occupation Certificate application is to satisfy all of the requirements of the *Environmental Planning and Assessment Regulation 2000*.

- 5.4 Complete the landscaping works.
- 5.5 Provide mail receptacles appropriately numbered for each dwelling unit in the development, as well as for the managing body, in consultation with Australia Post.
- 5.6 Contact Council's Land Information Officer or email ask@centralcoast.nsw.gov.au for allocation of a street address for the Secondary Dwelling.
- 5.7 Complete the building in accordance with the relevant provisions and requirements of the National Construction Code Series.

6. ONGOING OPERATION

- 6.1 Operate and maintain all external lighting so as not to impact on any adjoining property.
- 6.2 Do not let, adapt or use the dwelling for separate occupation in two or more parts.

7. PENALTIES

- 7.1 Failure to comply with this development consent and any condition of this consent may be a criminal offence. Failure to comply with other environmental laws may also be a criminal offence.

Where there is any breach Council may without any further warning:

- Issue Penalty Infringement Notices (On-the-spot fines);
- Issue notices and orders;
- Prosecute any person breaching this consent, and/or
- Seek injunctions/orders before the courts to retain and remedy any breach.

Warnings as to Potential Maximum Penalties

Maximum Penalties under NSW Environmental Laws include fines up to \$1.1 Million and / or custodial sentences for serious offences.

ADVISORY NOTES

- Discharge of sediment from a site may be determined to be a pollution event under provisions of the *Protection of the Environment Operations Act 1997*. Enforcement action may commence where sediment movement produces a pollution event.
- The following public authorities may have separate requirements in the following aspects:
 - a. Australia Post for the positioning and dimensions of mail boxes in new commercial and residential developments
 - b. Jemena Asset Management for any change or alteration to the gas line infrastructure
 - c. Ausgrid for any change or alteration to electricity infrastructure or encroachment within transmission line easements
 - d. Telstra, Optus or other telecommunication carriers for access to their telecommunications infrastructure
 - e. Central Coast Council in respect to the location of water, sewerage and drainage services
- Carry out all work under this Consent in accordance with SafeWork NSW requirements including the *Workplace Health and Safety Act 2011 No 10* and subordinate regulations, codes of practice and guidelines that control and regulate the development industry.

- Dial Before You Dig
Underground assets may exist in the area that is subject to your application. In the interests of health and safety and in order to protect damage to third party assets please contact Dial Before You Dig at www.1100.com.au or telephone on 1100 before excavating or erecting structures. (This is the law in NSW). If alterations are required to the configuration, size, form or design of the development upon contacting the Dial Before You Dig service, an amendment to the development consent (or a new development application) may be necessary. Individuals owe asset owners a duty of care that must be observed when working in the vicinity of plant or assets. It is the individual's responsibility to anticipate and request the nominal location of plant or assets on the relevant property via contacting the Dial Before You Dig service in advance of any construction or planning activities.
- Telecommunications Act 1997 (Commonwealth)
Telstra (and its authorised contractors) are the only companies that are permitted to conduct works on Telstra's network and assets. Any person interfering with a facility or installation owned by Telstra is committing an offence under the Criminal Code Act 1995 (Cth) and is liable for prosecution. Furthermore, damage to Telstra's infrastructure may result in interruption to the provision of essential services and significant costs. If you are aware of any works or proposed works which may affect or impact on Telstra's assets in any way, you are required to contact: Telstra's Network Integrity Team on phone number 1800 810 443.
- Install and maintain backflow prevention device(s) in accordance with Council's WS4.0 Backflow Prevention Containment Policy. This policy can be found on Council's website: www.centralcoast.nsw.gov.au

This condition only applies if installation / alteration of plumbing and / or drainage works proposed (excludes stormwater drainage).